



*Are clubs known as ...*

St. Louis Pocket Vertical  
Dew Coating NFOK ..... 3  
Vacuum Tube Transmitter  
Floyd Carter K6BSU ..... 21  
NCBA on Steroids  
Gary Surrency AB7MY ..... 26

PLUS

- Surface Mount for QRPers
  - FL Smith TICC Keyer Kit
  - An LED SWR Indicator
  - Microphone preamp for the K-2
- ...and more

**"The Tuber"**

**K6BSU's QRP Transmitter**



## Table of Contents

From the Editor .....	2
Doug Hendricks, KI6DS	
St. Louis Pocket Vertical and St. Louis Coil .....	3
Dave Gauding, NF0R & Andy Becker, W0NVM	
Tuber: Vacuum State Transmitter .....	21
Floyd Carter, K6BSU	
An NC40A On Steroids .....	26
Gary Surrency, AB7MY	
The Time for Surface Mount Projects is Now!! .....	31
Doug Hendricks, KI6DS	
15 Meter Pad and Glue SST .....	37
Mike Fitzgibbon, N0MF	
The Fort Smith QRP Group P-TiCK Kit .....	44
Doug Hendricks, KI6DS	
An Improved LED SWR Indicator .....	54
Glen Leinweber, VE3DNL	
A Microphone Preamp for the Elecraft K2 .....	57
Jerry Haigwood, W5JH	
Members News .....	63
Richard Fisher, KI6SN	
Hints and Kinks for the QRPer .....	67

### From the Editor

by Doug Hendricks, KI6DS

It is so nice to be back in the groove again. I underwent triple bypass surgery in late November, and have been recovering very well. Paul Harden, NA5N, stepped in and did the entire Winter 99 issue for me, thank you Paul, you are a true friend. Thank you to all who sent cards and messages, you will never know how much it helped. I am doing fine, the prognosis is excellent, and I will be up to full speed very soon, if not by the time you read this. I returned to work on Feb. 1st, and have had no problems.

Because of my health, we have been very late and off schedule with QRPP. You have all been very patient. I thank you for that. We have made some changes. Paul Maciel, AK1P, is now handling the database for the mailing list for QRPP. If you have a question about your subscription, please contact him. His email address is pmaciel@inow.com. His mailing address is: PAUL A. MACIEL, 1749 HUDSON DR. SAN JOSE, CA 95124. Enjoy the issue and it is great to be back. 72, Doug, KI6DS

## St. Louis Pocket Vertical & St. Louis Coil

by Dave Gauding, NF0R

nf0r@slacc.com

&

Andy Becker, W0NVMM

arb@bbs.galilei.com

The St. Louis Pocket Vertical (SLPV) features a tapped air-wound St. Louis Coil. It is a high performance self-supporting portable antenna for travelers, bicyclists, backpackers and hikers. This useful 10-40M project can be built with readily available components and hand tools at a reasonable cost.

### Components

**Loading Coil:** The St. Louis Coil design is patterned after B&W Airduxâ. A heavy-duty mailing tube serves as a construction form. Slotted grommet edging supports and spaces the coil wire.

**Support:** The sixteen foot high break-down antenna support is fabricated from lightweight fiberglass kite tubing. A guying ring positioned at the six foot level also serves as the elevated coil mount.

**Mounting Base:** Additional fiberglass tubing and internal reinforcements form the mounting base. The base adapts to either hard or soft earth installations.

**Feedpoint:** This assembly with builder's choice of antenna connector is fabricated from double-

sided printed circuit board material.

**Radials:** St. Louis Radials or an equivalent portable radial system is recommended for the SLPV.

**Feedline:** Any 50 ohm coax.

### Materials, Parts & Tools

- 4 ea. 54.5 inch x .505 diameter fiberglass tubing. (Note 1)
- 1 ea. 54.5 inch x .414 diameter fiberglass tubing (Note 1)
- 4 ea. 3-1/2 inch x .411 diameter internal fiberglass coupler (Note 1)
- 1 ea. rubber end cap, 1/2 inch diameter (Note 1)
- 1 ea. slotted-wall grommet edging, nylon, 12-3/4 inches (Note 2)
- 1 ea. hard plastic stock, 1/8 inch thickness, 1-1/2 inch square
- 1 ea. doubled-sided printed circuit board, 2-3/4 inch square
- 1 ea. antenna jack, bulkhead (see construction notes)
- 22 ft braided black nylon guy

- line, 1/8 inch diameter
- 2 ea. brass fishing swivel, size #05
- 6 ea. brass fishing swivel, size #01
- 16 ft. solid copper wire, #14
- 4 in. #18 insulated wire, stranded
- 20 ft. ribbon cable (flat computer cable), stranded, two conductors
- 3 ea. medium alligator clips, serrated jaw (Note 3)
- 1 ea. micro alligator clips, smooth jaw (Note 3)
- 4 ea. heatshrink tubing, 1/8 inch diameter, 1 inch length
- 4 ea. heatshrink tubing, 3/16 inch diameter, 1 inch length
- 3 in. brass tubing, 3/32 inch diameter (Note 4)
- 4 in. heavy-duty cardboard mailing tube, 3-1/4 inch diameter, 1/8 inch wall minimum
- 4 ea. barn nail, 6 inch length or 3/16 inch diameter equivalent
- 8 ea. 2-56 x 3/8 inch machine screw
- 8 ea. 2-56 nut
- 24 ea. 2-56 washer (#2 flat washer)
- 1 ea. Goop® sealant/adhesive, 3.7 ounce tube (Note 5)
- 1 ea. two-part epoxy cement kit, 30 minute work-time
- 1 ea. high-speed drill bit, 5/64 inch diameter

- 1 ea. high-speed drill bit, 1/8 inch diameter
- 1 ea. high-speed drill bit, 1/4 inch diameter
- 1 ea. tapered reamer, 1/2 inch/13mm diameter
- 1 ea. aluminum miter box (Note 4)
- 1 ea. mini-hacksaw, 32-TPI blade (Note 6)

**Other Hand Tools & Supplies**

Standard hacksaw, files(s), fine emery paper, steel wool, combination square, wire cutters, needle-nose pliers, small screwdriver(s), ruler, tape measure, masking tape, soldering iron, solder, extra medium alligator clips, cellophane tape, isopropyl alcohol and a lubricant. Optional items include a hobby saw, nibbler, cartridge de-burring tool, clamps and a 1/16 inch drill bit.

**Support Construction**

1. Using the fine pitch mini-hacksaw trim the .505 fiberglass tubing into ten 18 inch sections, one 12 inch section and one 6 inch section. Use the miter box to produce a square cut. Rotate the tubing while cutting to control splintering. Finish the trimmed edges inside and out with a tapered reamer and emery paper.
2. Trim ten 2-1/2 inch ferrules

from .414 tubing and finish as above. Mark a reference line 3/4 inch from the end of a ferrule. Apply epoxy cement. Insert this end into an 18 inch section allowing 1-3/4 inches of the ferrule to project from the assembly. Repeat for the ten 18 inch sections. Cure overnight. Note this is the recommended time allowance for each cemented part.

3. Trim a 1/2 inch ferrule from remaining stock. Square the end and epoxy flush into the top of the 12 inch tube. This is now the tip section and holds the cotter pin eye for the upper radiator wire.

4. Drill a hole 3/8 inch from the top edge to match the diameter of the cotter pin. The hole can pass through both sides of the tubing. Trim so the eye projects just far enough from the tubing to accept the #05 fishing swivel holding the upper radiator. Install with epoxy cement.

5. Trim a 1-3/4 inch diameter disk from 1/8 inch plastic stock. Drill a hole in the center. Finish with a tapered reamer for a snug slip fit over a ferrule. Drill three equidistant 1/8 inch holes with centers 1/4 inch from the sides of the disk. This disk supports the upper end of the guy lines and serves as an insulated base for the air-wound coil.

6. Cut three 7 foot sections of nylon guy line. Terminate each end in a #01 fishing swivel and a locked knot. Melt the ends to prevent unraveling. The guy line assemblies install in a compact 5 foot diameter footprint.

7. For the guying stakes begin by cutting the barn nails to a length of 4-3/4 inches. Cement into each of three .411 fiberglass internal couplers leaving 3-1/2 inches exposed. Allow these assemblies to cure overnight.

8. The guying stakes socket into each other and then store conveniently inside an 18 inch tubing section. Add the rubber end cap to complete the packaging. Small screwdrivers stored separately can substitute for the custom guying stakes. Philips-type heads aid insertion into hard earth.

### **Base Mount Construction**

1. Trim a 2-1/2 inch ferrule and apply epoxy cement. Insert into the 6 inch section of .505 tubing leaving 1-3/4 inches projecting from the end. The lower end of the support tubing will be socketed on this ferrule.

2. Using a file bevel one end of the last .411 fiberglass internal ferrule to a 35-45 degree angle. This alteration will aid installation in soft-ground locations.

Now apply epoxy cement to the squared end of the coupler and insert in the bottom end of the tubing leaving 1 inch exposed.

3. Cut the head off the last barn nail. Sharpen the end by filing down each of the facets. Apply epoxy cement to the shank. Insert in the .411 coupler leaving 4-1/2 inches exposed to serve as a base pin. Set the completed assembly aside to cure overnight.

4. The base pin followed by graduated steps helps the mount adapt to a variety of soil conditions. The sharpened point stores safely inside the support's tip section. Add a cellophane tape collar to the .411 coupler body for a snug fit.

### Feedpoint Construction

1. Trim a 2-3/4 inch diameter disk from the double-sided printed circuit board material. Drill a 1/4 inch hole in the center. Use a tapered reamer for enlarging and finishing. The feedpoint disk should have a friction fit along the base mount ferrule. Then drill another hole in the disk sized for the bulkhead antenna jack.

2. Form a 1/4 inch diameter loop from solid wire along with an 1/8 inch lead. Solder into the solder cup of the jack. This serves as a

solid attachment point for the alligator clip terminating the lower radiator.

3. Polish both sides of the pcb material with steel wool. Install the antenna jack firmly with a toothed or split-ring washer to ground both sides of the disk. Portable radials attach quickly to this assembly using alligator clips. The feedpoint offers some wet weather protection for the coaxial connection.

### Coil Construction

1. The SLPV features a St. Louis Coil for 10-40M built on a 3-1/4 inch diameter cardboard mailing tube form. The frequency coverage as well as the diameter and length of the coil can be changed to meet builder requirements. No alternate coil winding data is available.

2. With a hacksaw or diagonal cutters trim four grommets containing nineteen complete notches. Using the 5/64 inch drill bit place holes for the 2-56 attachment hardware in the outboard notches in the top and bottom of each grommet. Now drill additional holes in the second bays of grommets number 1 and number 3. These holes are identified as points A & B and points C & D in the diagram. The letters mark the locations of the horizontal coil supports.

3. Locate equidistant positions around the mailing tube for the four grommets. Layout vertical guidelines using a combination square. Then drill twelve matching holes in the tube with the 5/64 inch drill using each grommet as a separate template. Now install the grommets with the 2-56 hardware using the outside holes at the top and bottom of each grommet.

4. Place two washers between the grommet and the coil form. Place one washer between the nut and the coil form. Removing the stacked washers later helps to ease the completed coil off the cardboard without damage. The coil form is re-usable.

5. Attach the far end of the #14 wire to a solid object. This provides constant tension on the wire while turns are placed on the coil. The wire should be taut but not so tight as to distort the grommets.

6. These instructions are for a right hand coil. The starting point is on the left side of the form. Push the wire through the locating hole at point A. Allow the wire to project 1/2 inch inside the cardboard. Begin winding the coil clockwise after making a tight 90 degree turn to lock the wire in place. The stub will serve as

the attachment point for the upper horizontal coil support.

7. Continue winding the coil towards the right side of the form placing uniform pressure on the wire. Drop down one notch each time the wire meets itself. Inspect to insure the wire is positioned firmly in the bottom of each notch.

8. Finish the winding by trimming the wire 1 inch past grommet 3. Then bend the wire into a 90 degree angle at point C and push the wire through the opening. Pull the wire taut using a pliers. Trim the wire so it projects 1/2 inch inside the coil form. This stub will serve as an attachment point for the horizontal support at the bottom of the coil and the tap wire assembly.

9. Install the applicator tip on the Goop tube. Cut off the end of the tip at the first step. Apply a bead of the adhesive along the top of the turns inside grommet 1. The rule-of-thumb for bead size is three-quarters of the width of the grommet before the adhesive starts to settle. Avoid putting adhesive over the holes at points A & B and C & D and beyond at this time.

10. Now rest the upper edges of the nylon grommet under a 100W light bulb positioned horizontally. Slide the grommet

back and forth so the Goop is exposed to heat. Several slow full-length passes over a sixty-second period are sufficient. The warmed adhesive will pass through the coil wire and onto the body of the grommet to create the bond. Repeat the process for each grommet. Cure for a minimum of twenty-four hours before handling.

11. Remove the coil attachment hardware. Lift the ends of the grommets and slide the stacked washers free with a small screwdriver blade. Push the wire stub at point A and point C outwards until they are just clear of the coil form. The fit between the coil and the form will be tight. Use finger pressure on the ends of the grommets and gently ease the coil off the form in small increments. Then bend both wire stubs back into position.

12. If it is difficult to separate the coil from the form score the mailing tube internally with a fine hobby saw. It is not necessary to cut completely through the cardboard. Using a screwdriver passed between turns gently bend one edge of the cut inwards to reduce friction. Then remove the coil.

13. The coil supports are fabricated from a single piece of #14 wire. For the lower support start with 8 inches of wire. Bend

around a .505 tube section to create a coil-centering ring. Continue looping the wire until it forms an angle of 300 degrees. This occurs at approximately 1-3/4 turns. Using a pliers bend the wire ends backwards until both extensions are centered on the loop and perfectly straight. Confirm the fit along the fiberglass tube. Squeeze the turns together with an alligator clip and solder closed. Pre-trim each wire extension to 2 inches.

14. The tap assembly is installed on the lower coil support. Begin with 3-1/2 inches of #18 insulated stranded wire. Strip 1/4 inch and solder the wire into the body of the micro-alligator clip. Fold the crimp tabs over the insulation and finish the connection with 1/8 inch heatshrink tubing.

15. Using the mini-hack saw trim a 3/4 inch length of 3/32 inch brass tubing. Then cut this tube almost through in the middle to form a socket. Bend open to an angle of 300 degrees. Slide on to the lower or outboard arm of the horizontal support wire with the cut opening facing inside. Do not solder the socket or tap wire in place at this time.

16. Trim a 1/2 inch length of 3/32 inch brass tubing to serve as a coupler between the coil stub at point C and the inboard end



of the horizontal support wire. Slide the coupler on the stub. Now slide the end of horizontal support with its previously prepared tap socket through the bottom hole of grommet 1.

17. Trim the horizontal support until the wire ends at point C are socketed in both sides of the coupler and the coil ring is centered. The stepped configuration of the outboard wire extension allows the tap socket to mate with the pre-drilled hole at the bottom of grommet 1.

18. During fitting several medium alligator clips are useful for holding the horizontal supports in their final positions and for heatsinking. Now heatsink the coil centering ring. Heatsink the wire stub at grommet 3. Then solder both sides of the coupler to the wires. Trim the excess wire flush where it projects past the edge of grommet 1.

19. Slide the tap socket along the horizontal support and position 3/8 inch from grommet 1. Confirm that the socket will not interfere with the guying ring when the coil is installed on the tubing. Tack-solder the socket to the horizontal support with the tap wire opening pointing down.

20. Heatsink the support at grommets 1 and 3. Heatsink the soldered joints on both sides of

the support coupler. Heatsink the soldered joint on the coil-centering ring.

21. Now strip 1/2 inch of insulation from the tap wire and add the last 1/8 inch heatshrink tubing. Put the tap wire in position and heatsink the tap wire insulation where it touches the socket.

22. Elevate the coil and work from below. Solder the tap socket and the tap wire at the same time. To insure a strong joint the tap wire itself should pass through the socket and meet the horizontal support. Heatshrink the tap wire connection in the socket to finish the assembly.

23. Refer to paragraphs 13 through 18 for completing the upper horizontal support after omitting the tap feature.

24. Confirm the fit of the coil on the guying ring and along the fiberglass upright. File all soldered joints smooth. Fill the grommets at points A and C with additional Goop after clamping or taping the horizontal supports in their final locations. After curing trim off the unneeded grommet material

25. The standard SLPV coil has a measured inductance of 18 microhenries and a "Q" of 350.

There are sixteen full-turns and two half-turns. The coil contains 14-3/4 feet of wire including the horizontal supports and tap assembly.

### Radiator Construction

1. Two shorted parallel conductors of ribbon cable are used for the upper and lower radiators. This wire configuration is lightweight, strong and most importantly resists tangling during handling. Measure for the radiators after the fiberglass support and coil are in position overhead.

2. For 40-30-20M install six 18 inch tube sections and the 12 inch tip section. For 17-15M use one 18 inch section and the tip section. For 12-10M no upper radiator is required. Use the tip section for positioning the coil or trim a piece of leftover .505 tubing to length.

3. The upper radiator length varies according to the band. The table (Note 7) provides approximate tip-to-tip dimensions. Start with the #05 fishing swivel soldered in place. Allow for two shallow turns between the cotter pin and the horizontal support at the top of the coil. Now add the 1/8 inch and 3/16 inch heatshrink tubes. Finish the ribbon with a crimped and soldered medium alligator clip. Heatshrink the connections.

4. The lower radiator is a constant at approximately 6 feet. Allow for two shallow turns along the lower support when measuring. Add two lengths of 3/16 inch heatshrink tubing to the wire. Terminate each end in a medium alligator clip as above. Heatshrink the connections.

### Radial System

St. Louis Radials (QRPP, Fall 1997) fabricated from ribbon cable are recommended accessories for the SLPV. This is an easily managed and truly portable radial system. Each multi-conductor radial attaches to the feedpoint disk with an alligator clip. The ribbons rest on the ground and install or retrieve in minutes.

All construction information is contained in the referenced article. SLR ribbons are also accessories for the St. Louis Express vertical (QRPP, Summer 1998). Additional building and operating notes are contained in that article.

Single-length ribbons or the resonant ribbons can be used with the SLPV. Either radial configuration may be optimized for specific bands. The ribbons can be bent near their mid-point to fit available space.

A traditional ground radial system composed of single wires is usable with this antenna in either portable or permanent

locations. The length and number of wires and should be appropriate for a ground-mounted quarter-wave vertical antenna.

On-air testing of the SLPV was carried out with six St. Louis Radials extended full-length from the feedpoint and spaced proportionally. Each ribbon contains 7 parallel 16-1/2 foot conductors. This arrangement places 700 feet of wire under the antenna in a 33 foot diameter footprint.

### **Installation - Lower Support**

1. When the SLPV mounting pin is inserted in firm earth the lower support assembly will free-stand thus expediting the installation process. The following procedures are appropriate for soft ground or sand.

2. Attach the guys to the guying ring. Attach the feedline to the antenna jack and slip the feedpoint disk over the base mount. Position these sub-assemblies where the antenna is to be installed.

3. Insert two guying stakes including guys into the earth at a 45 degree angle about 120 degrees apart. Assemble four 18 inch tubing sections for the lower part of the support. Place the guying ring assembly on the top ferrule.

4. Now bring the lower support

to an upright position. Slip it onto the base mount with the previously installed feedpoint disk. Then insert the complete lower support assembly into the earth. Finally, extend and install the third guy.

5. Adjust the guys until the support is vertical. The guys should be firm to the touch but not tight enough to bend the lower support tubing.

### **Installation - Upper Support, Loading Coil and Radiators**

1. Buff the surfaces of the horizontal coil supports with steel wool where the upper and lower radiators will be attached. Buff the coil itself along the tapping bays.

2. Assemble the remaining tubing sections finishing with the tip section. Attach the upper radiator to the cotter pin eye.

3. Hold the coil so the tap assembly is facing down. Slip the base of upper fiberglass support into the coil. Then elevate both sub-assemblies together and place on the ferrule above the guying ring. A smooth vertical rise followed by a prompt drop into position works best.

4. Now attach the upper radiator to the horizontal support wire at

the top of the coil. Attach the lower radiator to the soldered loop on the feedpoint jack and then to its horizontal coil support. Place the shallow turns along the upright to keep each radiator secure.

5. Attach the radial system to the feedpoint disk. This completes the installation and the antenna is ready to be tuned.

### Coil Tuning

1. The St. Louis Coil can be matched for each band by trial-and-error using a sensitive low-power SWR bridge. A noise bridge or a direct frequency read-out device may also be used to resonate the antenna.

2. The table (Note 7) provides coarse tap locations for the standard coil and radiator assemblies operating over a St. Louis Radial set. Start with the lowest design frequency and move to the highest.

3. Using 40M as an example begin tuning by attaching the tap to the second turn from the bottom of the grommet supporting the tap wire assembly. When using an SWR bridge apply low power (1-2 watts) and compare the forward and reflected readings.

4. Fine tune by repositioning the

tap along that turn on either side of the grommet. During testing the tap wire may be extended temporarily with a jumper. Additional tap options will be discussed in the construction notes section.

5. Expect a 3:1 to 1 SWR reading or higher at non-resonant points. Reaching a 2:1 to 1 SWR suggests the resonant point is on an adjacent turn. Typical SWR at resonance is between 1:2 and 1:5 to 1.

6. Users faced with a difficult match should first try adjusting the upper radiator length. Changing the feedline length is an option. Adding several resonant wire radials specifically for a problem band may be helpful. Finally, a small matching coil could be fitted at the base of the antenna.

7. Apply 5 watts to confirm the accuracy of resonant points determined at low power. Then increase to 50 watts if available. If the SWR increases significantly repeat the tuning process until a reliable match is achieved.

8. Using the SLPV at multiple operating sites means changing RF environments. Besides external influences the proximity of the feedpoint to the earth and even radial positioning become contributing factors. Those and

other complex interactions may call for different tap settings.

9. Once a coarse tap location is established for a band the final match is generally easy to restore. On rare occasions when a tapped coil cannot produce an acceptable SWR the antenna can be fine-tuned with a transmatch after coarse tuning with the tap.

### Construction Notes

The standard SLPV tap assembly serves 2 bays and 33 tapping points. The tap wire may be built longer to reach the all bays in the coil though this is not normally necessary to achieve a usable match.

The tap design can be simplified by converting to a separate jumper wire with dual-alligator clip terminations. The jumper attaches anywhere on the lower horizontal support or to the end of the coil assembly at point C. This tap option is useful for emergency repairs and is a recommended accessory for an SLPV routinely exposed to rough handling in the field.

The coil may be built with detents in the bays. The tapping points decrease by one-half. However, the option may be appealing to some users as the possibility of shorting-out adjacent turns is reduced. Upper and lower radiator lengths remain the same. An updated coil-tuning

table is required.

To make the detents support the coil firmly in one hand. Starting with the second turn from the bottom in each bay push the center of every other turn inwards with a small flat-blade screwdriver. Apply pressure gently but firmly until the wire stops bending. The detents deflect about 1/2 inch. There is sufficient working space to replace the micro-alligator clip with a small serrated-jaw alligator clip.

The standard coil is adaptable to single-band use in a permanent location. Once an acceptable match is found replace the tap wire assembly with solid copper wire and solder in place. Route the wire inside the coil.

Choosing #14 copper wire for the coil was a compromise decision. #12 wire would provide better structural rigidity but it is heavier and slightly oversized for the .067 inch notches molded into the grommets.

Straightening out bumps in the copper wire by hand before winding the coil produces a more attractive sub-assembly and ultimately saves hand labor. Burnishing the fully extended wire with a fine steel-wool pad before winding is helpful as well. Use a needle-nose pliers for the final alignment of turns in a completed coil. Work from the edge of a grommet towards the center.

A compact mini hack-saw

(Note 6) with a very thin low-profile 32-TPI blade is recommended for trimming fiberglass stock manually. Thicker and deeper blades such as common 32-TPI hacksaw blades tend to splinter the brittle fibers. The rough edges require additional hand-work for a proper finish.

Alternative cutting methods include a hi-speed cutting disk or a lathe running at slow speed with a well-sharpened cutting tool. The performance of a fine-pitch razor saw varies in this application.

A handloader's cartridge case de-burring tool is handy for cleaning-up the cut edges of fiberglass tubing in place of a tapered reamer and emery paper.

The 3/32 inch diameter brass tubing tends to burr even when trimmed with the mini-hacksaw. A 1/16 inch drill bit is useful for restoring the fit of the tubing to #14 copper wire.

The heavy-duty 1/8 inch (minimum) wall mailing-tube is mandatory. It insures the form does not collapse under pressure from the coil during winding and subsequently aids with removal. Cut at least one end of the tube square with a hacksaw to insure the grommet reference lines are located properly.

Apply a coating of WD-40 or a silicone lubricant to the bottom of the grommets before installing them on the form. This provision is helpful when it is time

to remove the wound coil. Do not spray the cardboard directly.

There is room for at least three types of bulkhead antenna jacks on the standard feedpoint assembly. A full array includes a BNC, SO-239 and a double-binding post. The latter is suitable for a coaxial feedline without a mating connector.

The guying ring and feedpoint disk can be constructed as a square, triangle, hexagon as well as a circle. Cutting pcb material or plastic stock with a hacksaw instead of a nibbler may be more convenient for some builders.

The mating surfaces of the fiberglass tube sections and ferrules must be thoroughly degreased before epoxy cement is applied. Isopropyl alcohol on a Q-tip works well.

After construction the inside of each tube section and ferrule must be cleaned. This procedure removes fiberglass shavings and manufacturing residues that might otherwise foul the close fit between tubing and ferrule. Use a simple tissue plug sprayed with WD-40 or an equivalent product. Push the plug from end-to-end with a rod before the support is assembled. Finish with an isopropyl alcohol swab.

Depending on manufacturer or production lot the fit of fiberglass tube to internal ferrule may not be perfect. Minimum clear-

ance can be improved by using fine emery paper to reduce the diameter of the ferrule slightly. Proceed very slowly and test periodically for best results. A snug fit is desirable to insure the rigidity of the assembled support.

The standard SLPV is best suited to users not less than 5' 8" tall. This assumes installation of the upper fiberglass support at arms length while standing at ground level. The configuration of the support assembly is not critical. The positioning of the coil and radiators may be scaled up or down to meet builder needs.

### **Portability Features**

The final prototype SLPV with accessories and a standard St. Louis Radial set weighs 40 ounces without feedline. The fiberglass support with guying stakes stored internally and its companion mounting base bundle into a compact 2 inch diameter roll. Several 5/8 inch width small-diameter rubber bands used by food stores for fresh produce packaging are perfect for holding the tubes in place.

The disassembled support is less than 20 inches long. This feature allows the tubes to pack vertically inside a typical F.A.A. approved 21 inch rolling carry-on bag favored by air travelers.

The SLPV support also fits conveniently inside a mailing tube. Add foam plugs inside the

end caps to keep the fiberglass sections in place and trim the cardboard to length. The sections can be shortened to 16 inches (or less) overall to fit in a standard business briefcase or backpack.

While the homebrew antenna coil and companion radiators are quite durable the soft copper wire should be protected when not in use. Another cardboard mailing tube with foam end-plugs attached is a good choice. The feedpoint, guying assembly plus doubled and rolled St. Louis Radials will pack easily into a round rubber kitchen container.

### **Performance Issues**

The SLPV was designed with the low-power portable operator in mind. Nevertheless, the antenna has handled 50W continuously and 100W intermittently during testing. The upper power limit for each band has not been determined. The coil will de-tune when the closely spaced turns are wet with heavy-dew or rain. Options include operating temporarily with a higher SWR or removing the coil and drying it. A can of compressed air is a convenient alternative. Users should also anticipate changes in SWR readings between dry ground and wet ground locations. For short-term operating (on 20M only) jumper the full-length upper and lower

ribbon cable radiators with 3 inches of solid copper wire. The connected elements are resonant on the low end of the band.

Choose any 50 ohm coax feedline including a short length of RG-174 should carried weight and volume take precedence. The final SLPV prototype continues with field-testing using 75 feet of RG-58 coax. The feedline has a coiled choke at the feedpoint and BNC connectors at both ends.

The standard 16 foot SLPV support will suspend a light-weight dipole, inverted-vee or random wire. The specialized St. Louis Doublet (QRPP, Spring 1999) and the NorCal Doublet (QRPP, Winter 2000) are appropriate for this application. With the addition of a second guying assembly and modified installation techniques the .505 fiberglass tubing can be extended to 20-22 feet.

Excess .505 and .414 tubing can be converted into extenders to restore feedpoint height when the base mount is inserted deeply into soft ground or sand. Grind down the anti-withdrawal rings on barn spikes used in the mounting base and guying stakes. Then coat with epoxy glue. This controls rusting and makes it easier to remove dirt and debris.

The close part tolerances that insure rigidity in the fiberglass support system are a po-

tential drawback for the portable operator. Temperature extremes may tighten clearances to a point where assembly and disassembly are difficult. Several flexible rubber pads designed for gripping bottle lids are a useful addition to the field kit.

Finally, a very specific reminder that nearby foliage, structures, automobiles and antennas tend to absorb vertically polarized RF. With this in mind users should make every effort to position the SLPV in the clear for best results on the air.

### **Other Coil Applications**

A St. Louis Coil can replace the base-mounted twinlead coil of the original St. Louis Vertical. Size the coil-centering rings for a slip-fit on the tapered body of the 20 foot South Bend collapsible fiberglass fishing pole or similar products. The coil can rest on an edge where sections telescope or on a tie-wrap stop.

The modified coil is placed on the pole before it is installed. Therefore it is possible to locate the coil higher on the support than the 6 foot level used for the SLPV. The base of the pole and feedpoint may also be raised further. Changing taps on an elevated coil requires more time but the potential for reduced ground losses and a lower angle of radiation makes it an attractive option.

Customized St. Louis Coils

**QRPP Spring 2000**



can be used for shortened wire dipoles. Lighter coil wire and lower profile grommet edging are suggested for this application.

A St. Louis Coil has been tested in place of the toroid inductor in an original St. Louis Tuner kit (QRPP, March 1996). Due to its larger cabinet the NorCal version is better suited to this modification.

### **Antecedents & Variations**

W6MMA's commercial coil modification for the St. Louis Vertical readily adapts to the SLPV support system. Place the SLV/W6MMA coil for 10-40M on top of the guying ring. Tune normally after trial fitting new upper radiators. The foam bushings may have to be replaced to center the pvc form on the fiberglass tubing. See

<http://www.fix.net/~jparker/w6mma.htm>

AE0CW's (ex-N0TFI) homebrew tapped coil modification for the St. Louis Vertical uses foam pipe insulation for a coil form. In addition to being ultra-lightweight this inexpensive design builds quickly and is easily fitted to the SLPV support. See

<http://www.rmham.org/ae0cw>

The three-point St. Louis

Pocket Vertical guying system is based on the Random Wire Vertical antenna (QRP Quarterly, January 1995) or see

<http://www.g3ycc.karoo.net>

Extending the guy lines to 8-1/2 feet provides a convenient tent (or lean-to) foundation for camping. Each side of the tent is 9 feet long at the base. A fully enclosed space sleeps three persons plus some gear. The height of the guying ring allows an adult to stand upright. No tent plans are available.

### **Conclusion**

The St. Louis Pocket Vertical with a St. Louis Coil is a specialized portable antenna for the outdoor enthusiast, vacationer or business traveler. It is compact, self-supporting, lightweight and provides 10-40M capability practically anywhere in just a few minutes.

The SLPV project was under development for over one year. Four prototypes were constructed to verify electrical and mechanical function. Informal on-air testing conducted over several months included two hundred CW contacts at one-watt output across seven bands. That log is available to prospective builders. E-mail requests to [nf0r@slacc.com](mailto:nf0r@slacc.com) with "SLPV

Test Log" on the subject line.

The radiator uses a proven vertical antenna concept that is well-documented in amateur radio antenna manuals. Users will not be disappointed with performance either in the field or at home. As always, modifications and improvements are officially encouraged.

The text fully upholds homebrewers wishing to construct the complete antenna or only the coil. The SLPV project is labor intense though not without appropriate rewards. Having said this both authors concur that it has taken longer to write this article than to build and field test any of the prototypes.

### **Text Notes and Tuning Table**

1. Fiberglass kite tubing is available from Hang-em-High at

<http://www.citystar.com/hang-em-high/cat-2.html>

or (804)233-6155. Reference p/n FGT505 and p/n FGT414. Note that the .414 tubing used for internal ferrules is not carried by all retailers of kite building materials. The drilled solid fiberglass rod used for internal couplers in .505 tubing is p/n IF411. The rubber end cap for .505 tubing is p/n VEC12.

2. Slotted-wall nylon grommet

edging is typically an OEM product but available by the piece from some electronics parts distributors and surplus outlets. The SLPV prototypes use Panduit p/n GE-192. An example is pictured on page 136 of an on-line catalog at

<http://www.panduit.com>

The manufacturer of this semi-rigid material is not critical. However, the slot width should be .067 to match the diameter of #14 copper wire. Note that grommet edging is not the same product as caterpillar grommet which is flexible and sold on spools.

3. The medium alligator clip (RS 270-346B) and small smooth-jaw micro alligator clip (RS 270-373B) are stock items at most Radio Shack® stores.

4. 3/32 inch diameter brass tubing and a small Excel<sup>®</sup> Hobby Tools #55665 aluminum miter box are available at many full-line hobby shops. See

<http://www.phoenix-model.com>

for a picture.

5. Goop<sup>®</sup>, a clear non-silicone sealant/adhesive, is available at most major hardware and automotive supply stores. Any variation within the product family is usable. The marine, outdoor and

sportsman types are UV resistant to limit discoloration. Call (800)349-4667 for local retail sources other than Home Depot, Lowes, Wal-Mart, Tru-Value, etc. There is no active website for this product.

6. A Zona #680 Junior Hack-Saw is carried by "Into The Wind" at

<http://www.intothewind.com>

or (800)541-0314. Reference the nine-inch #4920 saw and #4921 32-TPI saw blades for cutting fiberglass. An imported mini-hacksaw with 32-TPI blade recommended for cutting fiberglass tubing is available from Hang-em-High (Note 1) but has not been tested. Reference p/n SAW and p/n SAWB. These specialized

saws can be found in some local hobby, woodworking and craft stores.

7. Coarse Tap Points for the Standard SLPV Coil (measured from bottom of coil at grommet 1) and Upper Radiator Lengths (approximate):

Band	Turn #	Upper Radiator
40M	02	118"
30M	10	118"
20M	16	118"
17M	09	28"
15M	12	28"
12M	06	Not Used
10M	09	Not Used

Copyright 1999 by Dave Gauding, NF0R and Andy Becker, W0NVN - All Rights Reserved

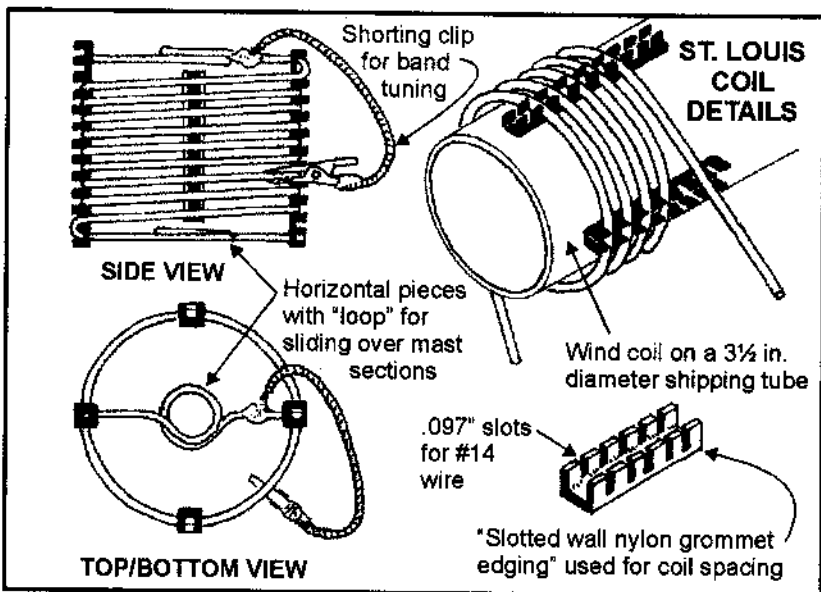

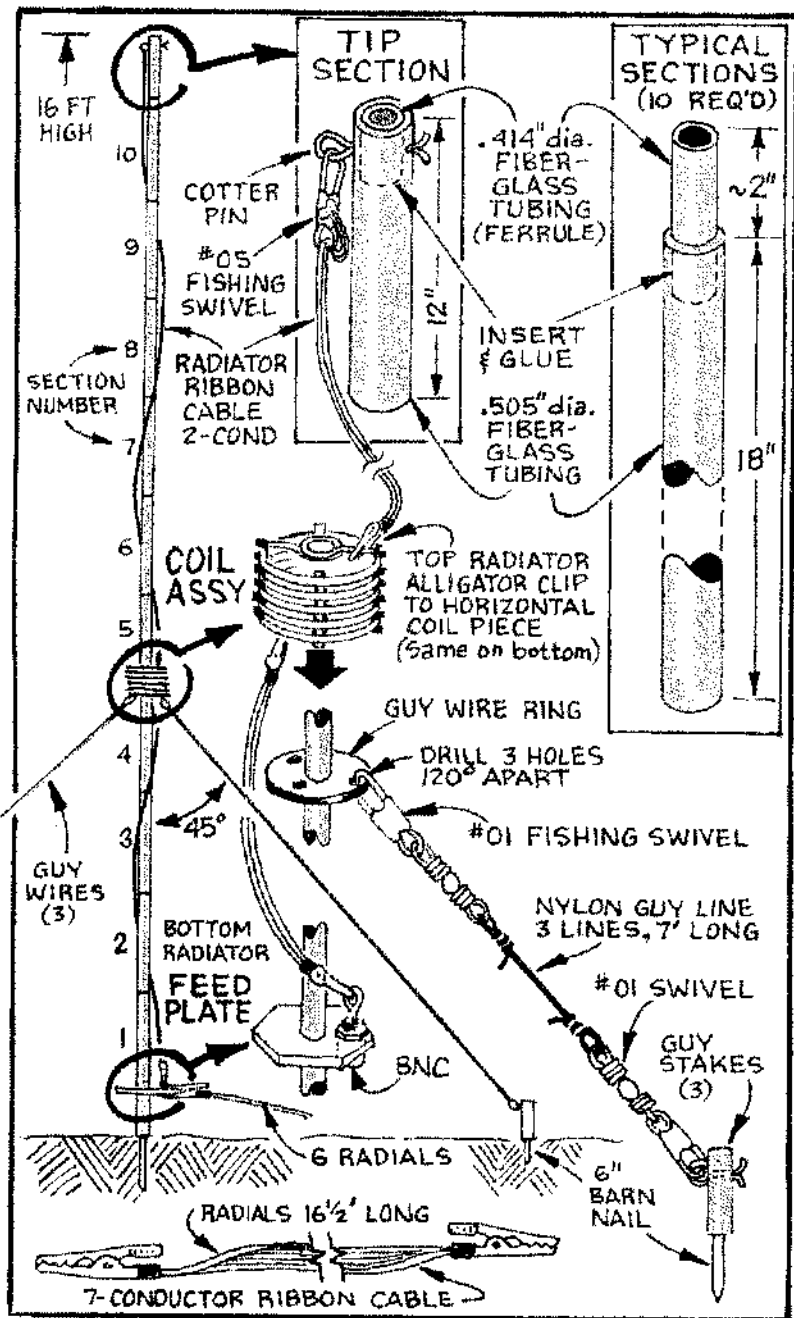

St. Louis Pocket Vertical Antenna

## Tuber: Vacuum State Transmitter

Floyd E. Carter K6BSU

2029 Crist Dr.

Los Altos, CA 94024

AeroPlyCo@aol.com

It doesn't seem very long ago that we designed and built our equipment using tubes. Here's a chance to take a trip into nostalgia-land and re-discover the fun of operating at night by the soft orange glow of the filaments.

The "Two-ber" is a 40 Meter crystal-controlled transmitter that delivers 300 mW into a 50 ohm load, thus putting it into the QRPp category. It uses two 6AU6 pentode tubes in a MOPA (Master Oscillator Power Amplifier) circuit. Why two tubes? Because "One-Ber" or "Three-Ber" would sound dumb. As a bonus, there is one tube to warm each hand on a cold evening.

I have long since scrapped my high voltage power supplies, and I imagine most other hams have also. Therefore, I designed the Two-ber to operate from 12 volts dc. This can be any convenient supply, but I was thinking of a 12 volt car battery for Field Day or QRP-to-the-field operation. The high voltage (remember that stuff?) is generated by a dc-dc converter, also running from 12 volts. Key-down current from 12 volts is 500 mA, with 300 mA of that total going

to light up the series-connected filaments.

The 6AU6 is a high gain pentode receiving tube. Perhaps other types would operate as well. However, there are still a few million 6AU6 tubes out there, whereas some of the more exotic bottles are hard to find. Many small tubes are still available at ham swap-meets for about \$1 each. In a pinch, you can actually order tubes from Radio Shack! (but be prepared to write a big check).

V1 is a TGTP (Tuned grid, tuned plate) oscillator. The crystal frequency at 40 Meters can be moved 6 KHz total by C1 acting with RFC1. My crystal, purchased from Doug Hendricks, is marked "7040 KHz" and it tunes from 7037 KHz to 7043 KHz.

The oscillator tube runs continually during transmit, and keying is done at the amplifier cathode. Z1 provides cutoff bias for the amplifier tube, boosting its efficiency and power output. A double pi network transforms the amplifier tube impedance down to 50 ohms. The large impedance transfer ratio requires a double-pi network, which also helps with cleaning up the har-

monics. I no longer have access to my beloved spectrum analyzer at Lockheed, (I am now retired) but the output looks good on a scope and its harmonics as found on a general coverage receiver up to 30 MHz are really weak. I can't verify if this rig meets the usual harmonic suppression goals, but it appears to.

### **200 Volt Supply**

The 200 volt high voltage dc source is generated by a dc-dc converter running from the 12 volt battery. The converter design uses a conventional two transistor multivibrator circuit. The "E-core" transformer is from Amidon, and is quite easy to wind. A Nylon bobbin is supplied with the two transformer cores. Place a 1/4" X 1/4" stick of wood through the bobbin for ease of winding. The 300 turn secondary is wound first. Reel off about 4 feet of wire from your wire spool and clamp the spool in a vise. Pull the wire just slightly taught and wind it onto the bobbin by rotating the bobbin. This prevents kinks in the wire. Repeat the procedure with another 4 feet of wire. You will get about 30 turns per layer. So 10 layers should complete it. Wind the layers as evenly as possible to conserve space on the bobbin. A layer of insulating tape is applied before doing the primary and feedback wind-

ings. After completing the windings, slip the two E-cores in place and epoxy them together. If the converter doesn't start up, reverse the feedback wires to the two transistor bases. The converter runs at 12 KHz and is quite vigorous. It will run down to 3 volts input. Don't omit the 100K bleeder resistor. It discharges the HV when you turn the dc-dc converter off during receive. Otherwise, the Xtal oscillator will continue to run too long.

### **Construction**

I built the Two-ber in "the open", so that I could do the show-and-tell thing at our club meeting. The RF deck is made on a piece of two sided copper-clad PC board, and the power supply on another piece of PC board. Wiring is point-to-point using the tube sockets and solder terminal strips from Radio Shack. The power supply transistors use the copper PC board material as a heat sink. Cut grooves in the copper board material to isolate the collectors of the power transistors. Many of the parts come from Radio Shack, and these are identified in the parts list.

### **Operation**

Tune-up consists of peaking up C4 and C11 for maximum output into a dummy load, then into an antenna. You need an

insulated tool for this. Remember, you are no longer working with a 9 volt transistor radio battery here! (keep one hand in your pocket when working with high voltage, as I was told in the army).

Not shown on the diagram is a DPDT switch which was later added to switch the an-

tenna to a receiver, and to cut off the 12 volts to the dc-dc converter during receive periods. Of course, the 12V to the tube heaters must stay on all the time. It is a good idea to install a 1 Amp in-line fuse in the +12 volt battery circuit for safety reasons.

#### **PARTS LIST: TWO-BER**

V1, V2	6AU6 or 6AU6A
RFC1	47 uHy RF choke
RFC2	1 mHy RF choke
C1, C4	9-100 pFd trimmer capacitor R.S. #RSU-11880051
C3	470 pFd silver mica
C5	150 pFd silver mica
C2, C6, C10	0.01 uFd disc ceramic, 500 V R.S. # 272-131
C7, C9	0.001 uFd disc ceramic, 500 V R.S. #272-126
C8	0.1 uFd mylar, 500V R.S. #272-1053
C11	10-180 pFd trimmer capacitor R.S. #RSU-11919099
C12	300 pFd silver mica
C13	750 pFd silver mica
C14, C15	0.1 uFd ceramic, 50V R.S. #272-1069
Z1	1N4735. 6.2 volt Zener diode R.S. #276-561
L1	12.9 uHy 51 T. #30. Amidon T50-2 core
L2	6 uHy 35 T. #30. Amidon T50-2 core
L3	3.57 uHy 27 T. #30. Amidon T50-2 core
All resistors	1/4 or 1/2 Watt 5%

#### **POWER SUPPLY**

Q1, Q2	TIP42 PNP power transistor R.S. #RSU-11371259
C1,C3	1 uFd elect. 35V R.S. #272-1013
C2	10 uFd elect. 350 V
R1	220 ohm 1/2 Watt
R2	100K ohm 1/2 Watt
D1-D4	1N4004 diode R.S. #276-1103
T1	EA77-250 core kit, Amidon Inc., 240 Briggs Ave., Costa Mesa, CA 92626 (714) 850-4667

Winding "A": 300 turns, #30 enameled magnet wire.

Winding "B": 30 turns center tapped, #24 enameled magnet wire.

Winding "C": 8 turns center tapped, #30 enameled magnet wire.

# The "Tuber" K6BSU

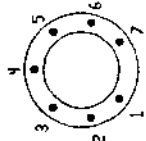
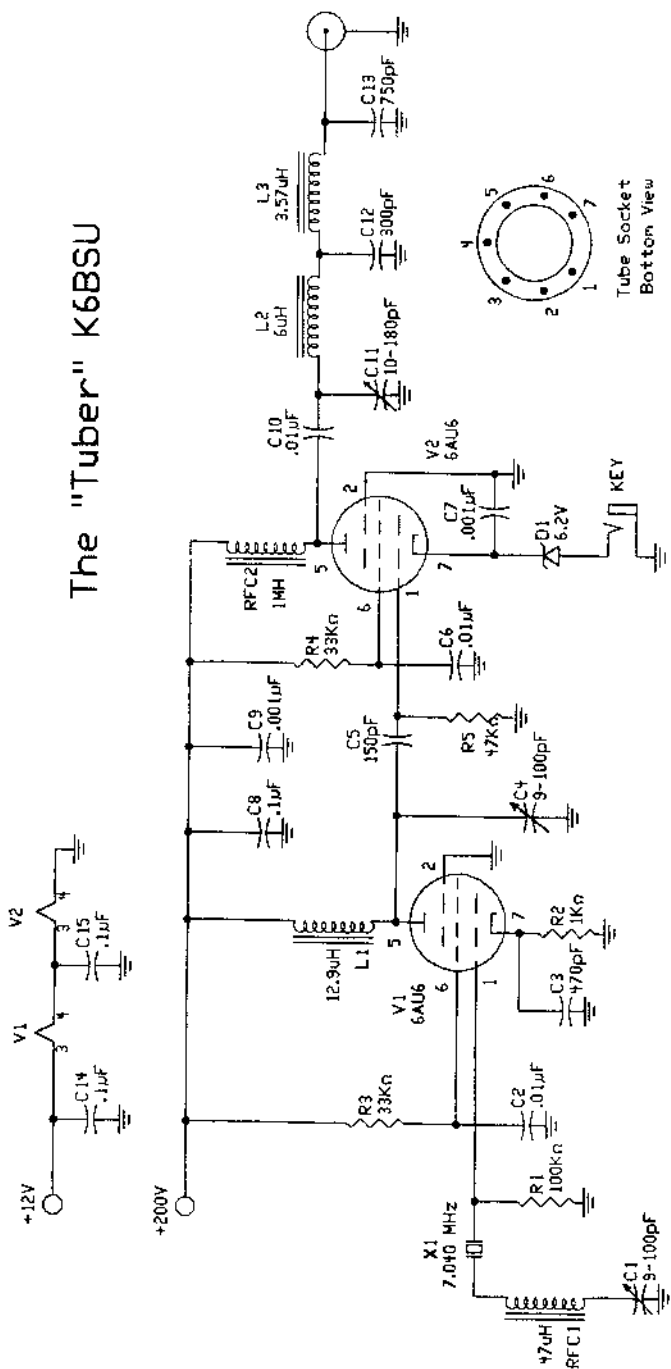

Tube Socket Bottom View



# "Tuber" Power Supply

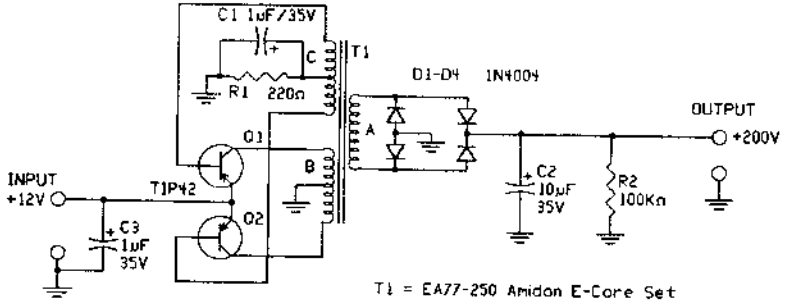

T1 = EA77-250 Amidon E-Core Set  
 A = 300 T. #30  
 B = 30 T. C.T. #24  
 C = 8T C.T. #30

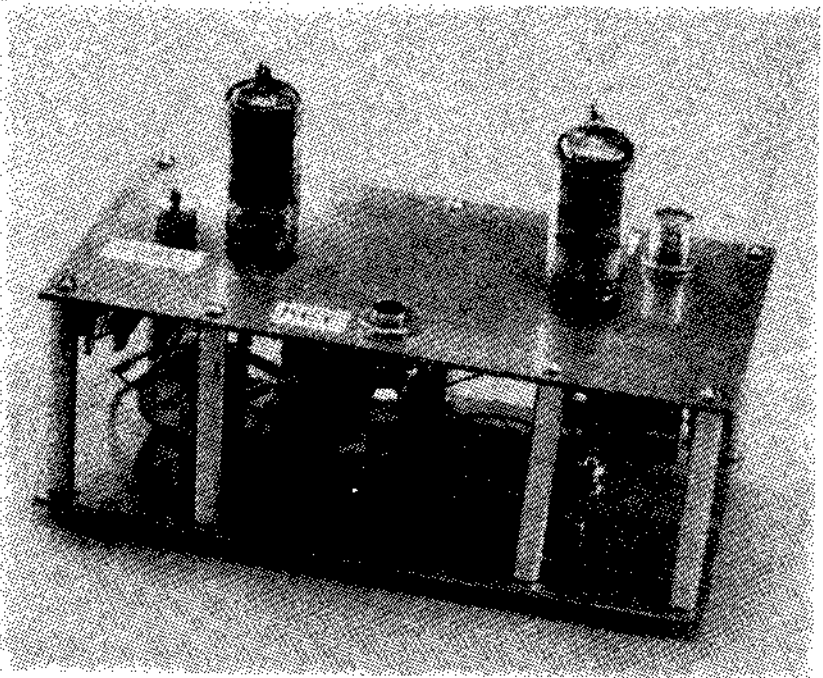

K6BSU "Tuber"

## AN NC40A ON STEROIDS

by Gary Surrency, AB7MY  
gsurrency@juno.com

I've been helping several folks on the QRP-L to increase their NC40A transmitter output power level. This article covers most of the things I've done to mine. There are a number of ways to get the output higher. The ideas I include here have worked well for me, and no hacking of the rig or cutting of traces in necessary.

The most increase in power I got with my Wilderness NC40A, was when I redid the PA low-pass filter (LPF). The original LPF is set up to operate with a higher collector load impedance for the PA operating at only 2 watts. The PA needs to see a load of about 19 ohms at 13.8V and 5 watts.

\*Equation 1, approximation of RF PA operating load impedance:

$$[ R_{\text{collector}} = (V_{\text{cc}})^2 / (2 * P_{\text{out}}) ]$$

or,

$$R_{\text{collector}} = (13.8)^2 / (2 * 5)$$

$$R_{\text{collector}} = 19.044 \text{ ohms}$$

If you operate strictly from batteries, then an even lower col-

lector load impedance is necessary to get the PA to "work" hard enough to develop 5 watts.

$$R_{\text{collector}} = (12.6)^2 / (2 * 5)$$

$$R_{\text{collector}} = 15.876 \text{ ohms}$$

As the original NC40A is set up for operation at 2 watts, we get:

$$R_{\text{collector}} = (13.8)^2 / (2 * 2)$$

$$R_{\text{collector}} = 47.6 \text{ ohms}$$

Or, for operation at 12.6 volts:

$$R_{\text{collector}} = (12.6)^2 / (2 * 2)$$

$$R_{\text{collector}} = 39.7 \text{ ohms}$$

Get out your MFJ-259B or other antenna analyzer, and hook it up to the antenna BNC jack. Leave the power off to the NC40A, and place a 39 to 47 ohm (or 51 ohm) resistor across the PA C and E leads. Tune to 7.040 MHz or so, and measure the SWR, resistance, and reactance. Then observe at what frequency the match is best. This will confirm how the LPF is actually operating.

As you can see, the original LPF was designed for an input and output of approx. the

same impedance, or 47-50 ohms. We can modify it so that the input impedance is lower than the output impedance, and thus force the PA to work harder. This could also be done with a tapped PA collector choke or transformer. But the PCB layout does not lend itself well to that type of mod, and simply changing the LPF is easier and less damaging than hacking up the PCB.

So let's change the LPF filter components to what I used:

should bring the antenna side match very close to an SWR of 1:1, 49-50 ohms resistance, and zero reactance. A perfect match is possible - but not absolutely necessary - as little difference in RF output will be seen when the match gets close. But try to eliminate the reactance value as much as possible, and center the filter on the desired operating frequency.

The new LPF is now set up correctly for 5 watt operation at 13.8 volts (or whatever other sup-

Original Filter		New Filter
C45	330pf	470pf
L7	18 turns on a T37-2	16 turns on a T37-2
C46	820	820pf (same cap)
L8	18 turns on a T37-2	19 turns on a T37-2 (or, 18 turnstightly wound)
C47	330 pf	470pf

Note: I used all ceramic caps and still got good results. Silver Mica caps have lower loss, and may gain you a db or so of output. NPO's are about as good and cost less than S/M. The most important thing is to get a good match from the input to the output.

Now put a 15 to 19 ohm resistor (use two 39 ohm 1/4w resistors in parallel, or use a 39 + 33 ohm, in parallel) across the C and E leads of the PA. Again use the antenna analyzer to read the match. Small adjustments to the inductor winding spacing

ply voltage and power level you choose with the appropriate equation values).

I retained the original 18uH solenoid choke at RFC1 in the PA collector, as some experiments proved it was just adequate. It barely gets warm at 5 watts output.

**BE SURE TO REMOVE THE ANTENNA ANALYZER BEFORE CONNECTING THE DC POWER AND TRANSMITTING!!!!**

Changing Q5 to a J310 will

help if the PA drive is low, as does the change of Q6 to a MPS2222A transistor. Or find another, better 2N2222A. Try several different devices and pick the "hottest" ones. Even some good quality 2N3904's will work for Q6.

Be sure that driver transformer T1 is carefully constructed. I rewound mine using #26 red enamel for the primary left over from building my K2. And some #26 green enamel was used for the secondary. Space the 14 turns of the primary around the entire core for 80-85% coverage. Then wind center the secondary windings, so that there are 4 turns of the secondary in the middle of the primary. When you are done, there should be 5 red wires on one side, and 4 red wires on the other side of the secondary. This insures the best transformer operation, and it looks best too. I left the finished core spaced just a little above the PCB, maybe 1/16".

A 220 ohm pot at R13 is a better choice than the original 500 ohm one, and it aids in setting the output level more easily. You could reduce R12 a bit from 20 to 10-15 ohms too, but I did not need to. I also changed the stock one-turn tuning pot to a 10-turn unit some time ago. It really makes the difference!

If the output will still not reach 5 watts, you might have

low VFO output. Changing the J309 in the VFO oscillator might help this, as we found out in some NC20 kits. You might even try a J310 there, but it will run hotter with its lower channel resistance (less  $R_{ds\_ON}$ ), and may increase drift. The J310 I tried also did reduce the VFO tuning range some. With the hand-selected J309 I ultimately used, the tuning range is about 51 KHz.

As a last resort, you can increase the size of capacitor C31 from 5 pf to 6-10 pf. Do not increase the size of this cap very much, as spurious output may increase with excessive VFO drive into the NE602. Without a spectrum analyzer or high quality oscilloscope to look at the signal, it is risky to increase C31 much above 10 pf. These mixers do not like too much signal into their inputs. I used a 10 pf for C31 in mine.

The size of C37 may also be increased from 5 pf to 10 pf. This further increases the signal level into the band-pass filter at Q5's input, and broadens the response of the filter a bit. Previously, the output tended to fall off a little too much at the limits of tuning, depending on what frequency I peaked the filter at. The result is a nice broad filter response – yet the output is still clean and a bit higher. Some 5 pf caps I've measured in the rig were low in value to start with.

At 7 MHz, they don't have a lot of reactance, so if they measure lower than they are branded – you ought to replace them. I used a AADE digital capacitance meter.

I toyed with the idea of using the balanced output of the NE602 into a transformer to gain a bit more output from U4. But I found this was not necessary, and would add unnecessary complexity to the design.

If your TX-derived sidetone is too loud or raspy, the increased power level from the transmitter into the receiver input may be reduced by trying another 2N4124A at Q1, and/or insuring that the AGC threshold is set correctly and Q2-Q3 and their associated components are working properly. My sidetone is not loud or distorted at 5w. I still have the 8.2 M resistor at R4.

With the PA LPF properly adjusted, there is no need to change the zener diode at D12, since the lower PA collector load impedance prevents the peak collector voltage from exceeding the original zener's voltage rating. It should not get warm, and the lower voltage helps protect the PA device better on brief antenna mismatches. But it will not save the PA from bad loads at full output. Be forewarned, as I have been there and done that, as Chuck says. Use an antenna analyzer to pre-set the antenna

tuner, or something like the ZM-2 that has a built-in resistive SWR bridge for some degree of protection during tune ups. I can't say enough good things about the ZM-2!

With all these "blueprinting" mods done to my NC40A, I can actually reach 7 watts with a 14.0v DC supply. Since the MRF237 is used is rather small, I play it safe and stay at 5 watts or below. Avoid long key down periods, and heat sink the PA well by putting the MRF237 under the PCB with its case (at ground potential) thermally greased and pressed against the bottom cover. I just started using this method on my rig, and it seems to be the way to go. The PA device runs cooler this way, and there's no worry about overheating as there is with almost any size of TO-5 / TO-39 finned heat sink you can find.

Or, you can put a \*large\* TO-5 heat sink on the PA mounted conventionally on the top of the PCB, such as the NTE401. Tip: bring along a spare PA transistor on camping trips and use IC socket pins for a quick-change PA, especially if you run the full 5 watts and you're careless about antenna matching. Be sure the heat sink used does not cause the PA to fall out when you transport the rig if you do socket it.

Some of these mods have appeared on the QRP-L before,

in my pastings about low-pass filters and about increasing the output of the Small Wonder Labs SW-30 and SW40 series. The DL-QRP PA module is another option. But these mods require the least modifications to the NC40A, and they can all be undone with no lasting damage to the original design, should you want to sell the NC40A later.

I chose to not incorporate another larger case style PA device such as the MRF476 in a TO-220 package, as I did not like the mechanics of different PA mounting and heat sink options. 5 watts is about all you can expect of a PA in a TO-39 or TO-5 package. The rig's PA \*is\* fragile at that power level since the breakdown voltage ratings are low and the case thermal resistance is high. And, the TX stages (U4, Q5, Q6) ahead of the PA are not suitable for much greater drive to any single PA device. In other words, these mods produce about the best compromise of power output and least circuit changes, given the original, excellent design. More power would also tend to upset the RX too much without re-designing the T/R circuit.

PA devices designed for operation at 13.8 volts \*are\* more efficient than ones designed for operation at 28 volts in this application. But they are also more fragile, and easier to destroy with high SWR. The 2N3553 is a

pretty good 28 V device, if your NC40A already has one. The 2SC799 is not as rugged, and will not go much more than 3-4 watts without expiring. The MRF237 and 2N3924 are designed for 13.6 V operation, and are best in this rig, but they are getting harder to find and are more expensive.

The 2N3924 is a bit more fragile than the MRF237, but it will do 5 watts plus and has the same EBC pin out as the 2SC799 and 2N3553. The MRF237 is easier to find, and will do 5 watts easily. But it really needs to be mounted upside down under the PCB and heatsinked to the bottom cover. It's reversed C and E leads make this possible. The case is connected to the emitter, which is grounded, so there's no need to insulate the case from the bottom cover. I haven't yet removed the paint from the bottom cover where the MRF237 is located, but it does not seem to overheat as best as I can tell. I might sandblast off the paint in the spot where the MRF237 sits one day if this one ever fails. So far so good. A very small top hat style TO-39 / TO-5 heatsink would help remove heat from the sides of the device, and might still fit under the PCB and against the painted bottom cover for better heat transfer.

Push-pull PA designs such as the one from the DL-QRP

club are more complex and not nearly as current efficient as the single class C PA stage used in this and most QRP rigs. But that PA is a very nice unit and I may have to get one just to play with!

Hopefully this info will help you and others that like the NC40 and just want more output for

tough conditions or poor (not mismatched) antennas. Mine works well, and has been tweaked about as far as it will go!

\*Reference: Solid State Design for the Radio Amateur, Copyright 1986 by ARRL, page 61.

## The Time for Surface Mount Projects Is Now!!

by Doug Hendricks, KI6DS

862 Frank Ave.

Dos Palos, CA 93620

[ki6ds@dospalos.org](mailto:ki6ds@dospalos.org)

[Reprinted with permission from QRP Homebrewer, Journal of the NJ QRP Club, Winter 1999)

NorCal QRP Club has done over 10,000 kits since we started the club back in 1993. I have sourced the parts on every one of those kits, and I have noticed a disturbing trend, it is getting harder and harder to find through hole, or leaded parts. The sources are just drying up. One of the companies that I do business with in the bay area does millions of dollars in the surplus parts business every year. The owner of that company told me recently that as recently as 5 years ago, he would get pallets of through hole parts, all that he needed. It is a much different story today. He told me that now he will get through hole parts in only one pallet out of ten, and that may only be a box or two in

the whole pallet. We have to face it, through hole parts are getting harder and harder to find. Plus, all of the new chips are being designed in surface mount. Since our economy operates under a supply and demand pricing system, the cost of these parts is going to go one direction, higher. Soon through hole parts will be like tubes are today. It is already starting. I used to pay 25 cents for a 2SC799 RF transistor, now, if you can find them they are \$2.50 - \$3 each!!

What are we to do? We love to build, but one of the advantages of building is that you usually get a better radio cheaper. If the parts cost are going to go up 10 times or more, soon that will not be the case. We only have one choice, we must go to surface mount parts, which are

currently in production in mass quantities world wide. That is the secret of cheap parts. Find something that is massed produced, and it will be much, much cheaper than things produced in small quantities, the old supply and demand theory.

Recently someone posted on QRP-L that we need to move out of the dark ages and start working with surface mount. The only surface mount kits that have been done in the past seven years, that I know of, are the TiCK Keyer by Embedded Research, and the SMITE, which was a surface mount version of the Pixie done by Bob Kellogg and the Knight Lights, a group of QRPers in the Carolinas. The TiCK is a simple kit with only 4 or 5 surface mount parts. The SMITE, while selling over 700 kits, was a very basic transceiver, and it is no longer being offered. I had talked with one of our designers about doing the next NorCal kit last fall. We wanted to offer something on 10 meters, but with a built in Keyer, DDS VFO, RIT etc. A full featured rig, but we wanted to do it for \$50. The designer suggested doing it surface mount, and I immediately agreed. We would have the fine pitch chips premounted and tested, but the rest of the parts would be surface mount where possible. That kit is in development now, and we hope to see a working

prototype by the first of May. Sorry, I can't reveal the designer at this time, as he prefers to not be deluged with email and questions about the new kit. Once the kit has been done for 10 meters, there will be versions done for 12, 15, 17 & 20 meters, but not by NorCal. Those will be commercial products.

When I announced the new NorCal kit on QRP-L, the response was huge. I got over 200 messages of encouragement on the project. I also got 3 messages telling me that it would never work, one even posted to the list a long message on how it was not necessary to go to surface mount parts. I obviously disagree. Another thing that was a recurring theme in many of the messages was that people wanted to have a kit that was an intermediate step between now and when the "full featured" NorCal 10 meter kit comes out.

I thought about this, and my first thought was to do the Tuna Tin 2 surface mount. I even layed out a board for it. Then I thought better about it. George Heron and the NJ QRP Club is already doing that kit, why compete with it?? It would be redundant. But I wanted something simple to do. Then I remembered Pacificon and the simple Tuna Tin 2/MRX Receiver kits that we did. Guys loved them and several did many modifications, including Dave Fifield, AD6A, of Red Hot Radio



and NorCal 20 fame. Dave had put his mods on his web page. I got on the internet and went to the Red Hot Radio site at [www.redhotradio.com](http://www.redhotradio.com). There it was, under TT2/MRX Mods. Dave listed the following specs for the rig after he did his mods:

- 500mW output into 50 Ohms (clean enough now)
- TX frequency variable from 7040.55 to 7042.03KHz
- varicap tuned (1.48KHz range)
- TX output envelope wave shaped
- Very little TX chirp (still a tiny bit, but I'm working on it!)
- RX tunes 7038.47 to 7042.72KHz (4.25KHz range)
- RX can hear -120dBm signals
- Full electronic QSK- No relays, no switches
- No thump!!!- Real sidetone (clean sine wave)

This would be a perfect candidate. I took a quick look at the parts, and there didn't seem to be anything esoteric in there. Wait a minute. It used an LM380-8 as an audio amplifier. I checked and that part is not available surface mount. But the LM386 is, and I knew that Dave could make the substitution with no trouble. This was on a Friday night. I called Dave, suggested that we meet for lunch the next day in San Jose at St.

John's Bar and Grill, one of our favorite restaurants.

My plan was to ask Dave if it would be very hard to do his version of the TT2/MRX with mods surface mount, and change the audio amp to an LM386. I would need his help, as he is an expert at laying out boards, and that is critical with transceiver design. The timing could not have been better. Dave agrees that we need to move to surface mount construction, but that we need to do it slowly, and in steps that are not so big that the average builder can't do the kits. He also plans to move to surface mount with his future Red Hot Radio kits, and welcomed the opportunity to learn about surface mount board layout. So it was a win – win situation. Dave would get the chance to learn, and NorCal would get expert assistance with board layout. The design was proven to work, so that would save a huge amount of time. It didn't involve a large amount of parts, only about 85, so it would be a simple kit. The only thing was to swap the LM386 in and the LM380 out, a simple matter for Dave Fifield.

We left the restaurant and went to Dave's house where we started the project. The first thing that we had to do was to determine what size parts that we were going to use. Surface mount resistors and capacitors

come in several sizes, all referenced in thousandths of an inch. The largest size are called 1206's and are 12 thousandths by 6 thousandths of an inch in size. The next size is the 805 class, which are 8 thousandths by 5 thousandths. There are also 603's and 402's. Dave works in Silicon Valley as an engineer. His company designs and manufactures products using surface mount technology. There is currently a 52 week lead time on certain values of capacitors in the 805 and smaller surface mount parts. But, there is a good supply of 1206 sized parts. This was perfect for us. The 1206's are the biggest and easiest to work with, and they are currently available, with no lead time!! We would go with the 1206 size.

Dave started laying out the board, while I searched catalogs for parts and package information. Three hours later we had located a source for every part description, and he had the package information that he needed to do the layout. I left to drive home, and when I arrived there 2 hours later, Dave called to say that he had the preliminary board done, and that it was 2.5" x 2.25" with the three control pots board mounted on the front edge of the board. Wow, quick work. Dave spent the rest of the weekend checking the layout, and sent it off to AP Circuits

in Canada to get a couple of prototype boards made. He ordered parts in small quantities to do the prototypes on Monday. The boards came in on Wednesday, Dave built and tested the prototype Thursday evening, and made his first qso on Friday! Total time from conception of the idea to working prototype, 1 week!! Dave Fifield is amazing.

George Heron of the NJ QRP club is a very good friend of mine, and we work closely together helping each other with NorCal and NJ club matters. We talk weekly on the phone, and have wanted to do a kit together for some time. But there were problems. We both use volunteer labor, and sometimes they don't get the work done as fast as it needs to be. How could we do a project together, yet be independent of each other? George solved the problem. I called him and mentioned that we were going to do the surface mount interim kit, and that we would call it the SMK-1. It would be a board and parts only kit. The light went on in George's mind, and he suggested that the NJ club do the case and connector kit!! Brilliant idea. I sent George measurements and locations for the holes for the front mounted controls. He and his people very quickly came up with a custom designed case and all of the rest of the parts needed to complete the SMK-1.

NJ would supply a case kit made from PC Board soldered together, the 1/8" phone jack, the 1/8" key jack, the coaxial power jack, and the BNC antenna jack. They would also supply the screws and feet for the case, plus the knobs for the pots!!

This was a huge help to us here at NorCal. We did not have to worry about the case!! The labor for doing that would be done by the NJ club. Another first for NJ QRP and NorCal. Two clubs working together to produce a kit, and the big winners are the QRPers!! This is exactly the role that clubs should be playing. The purpose of NJ QRP and NorCal are the same. We both want to do everything possible to enhance and promote QRP. We want to encourage building. We want people to learn how to do surface mount construction with a simple, easy to build kit, using the easiest to use surface mount parts. We believe in starting with the basics, and then going forward once we have the basics down.

The SMK-1 kit is a perfect first time surface mount kit. It has 85 parts, and all but the 3 control pots, two crystals, and the two trimcaps are surface mount!! There are IC's in the easy to do SOIC package (50 mil spacing, which is half that of a normal IC), transistors, diodes, resistors, capacitors, inductors, in short all of the normal parts

needed to build a radio. The size of the parts is not that small. The only special equipment you will need is a fine tipped soldering iron, a pair of tweezers, and eye magnification if you need it. The prototype was built by Dave without any magnification at all.

We are excited about this kit. It is a step into the unknown. We have had to come up with a system of packaging the parts so that they can easily be identified. What we came up with is that we will use a 3" x 6" bag and we will do 2 seals on it length wise. That will make 3 sections in the bag, 1" x 6". We will put parts in each section, and then seal it, to make a row of sealed parts across the bottom. Then we will put the next set of parts in the tubes, seal, etc. When we finish, we will have a bag that has been divided into 21 parts, with a component sealed in each section. The manual will have a "key" that is a matching diagram with the parts listed on the diagram. All that the builder will have to do is lay the bag over the diagram with the "key" in the proper place, and then he will be able to identify the parts. Very simple. That is why it works.

I must say that the sourcing of parts for the SMK-1 was the easiest kit that I have ever done. I found all of the parts and ordered them in ONE DAY!! By comparison, it took several weeks to do the NC20. The rea-

son is simple. We are using surface mount parts.

If you'd like to order an SMK-1 please send a check for \$34 (\$30 for the kit plus \$4 for shipping and handling US & Canada, \$6 Europe and \$8 Pacific rim) made payable to Jim Cates and send it to:

Jim Cates  
3241 Eastwood Rd.  
Sacramento, CA 95821

Please include a self addressed mailing label. It can be simply your name and address typed on white paper.

If you would like to order a custom designed matching case and all parts needed to finish your SMK-1, then do the following:

### **The SMK-1 Enclosure Kit**

The NJ-QRP Club is pleased to offer another "first" for the QRP community: a homebrew enclosure kit made entirely from double-sided copper-clad pcb material. Working closely with NorCal in the introduction of their SMK-1 transceiver, we designed an enclosure tailored to the small-sized SMK-1 and created a kit of all parts needed to finish off this surface mount transceiver.

### **Included in the SMK-1 Enclosure Kit ...**

8 precision-cut, pre-drilled copper-clad pc boards which,

when soldered together as instructed, form the enclosure to hold the SMK-1 Surface Mount Transceiver kit from NorCal.

3 knobs (for the pots included on the SMK-1 pcb from NorCal)

Rear panel hardware: two 1/8" audio jacks, a 2.1mm coaxial DC power jack, and a BNC connector;

2 small screws to hold the top half of the case to the bottom;

4 small screws and two nylon spacers to hold the SMK-1 pcb in place;

4 rubber feet

Pre-printed front and rear panel labels on clear acetate, suitable for gluing to the enclosure to give it a professionally finished appearance.

A 10-page, detailed instruction manual to guide the QRP homebrewer through construction and finishing of the SMK-1 Enclosure.

### **Price and Ordering for the SMK-1 Enclosure Kit**

The SMK-1 Enclosure can be purchased for \$10 from the NJ-QRP Club. This price includes shipping anywhere in the world. Send cash, check or Money Order payable to "George Heron, N2APB" and mail to:

George Heron, N2APB  
2419 Feather Mae Court  
Forest Hill, MD 21050

## **Conclusion:**

We plan on offering this kit for at least 1 year, in order that all will have an opportunity to build with surface mount.

One final thought. Don't be afraid to try surface mount. You can do it!! There will be tons of people available to help you through any problem areas, and together we will make you successful.

As a followup, we have shipped over 400 kits and everyone has been able to build it.

We have no reports of failures!! Guys are having tons of fun, and we have proven that Hams can and will build with surface mount. The Great SMK-1 experiment is a huge success. Again, we are still shipping this kit. It is intended as a beginner's course in working with surface mount components, not as a full featured 40 meter transceiver. The interesting thing is that many, many guys are reporting great success making contacts with the SMK-1. 72, Doug, K16DS

## **15 Meter Pad and Glue SST**

by Mike Fitzgibbon K10AF

[Reprinted with permission from the Iowa QRP Club Newsletter, Spring 1999]

The SST is a popular little minimalist-type transceiver with a surprising performance level, considering the parts count. Once again, Wayne Burdick, N6KR, did a great design/development job on the little rig. It is no wonder that the Wilderness Radio kit versions for 40, 30, and 20M have been quite a success. The kit has, however, never been offered for the 15M band.

Although a conversion of the 20M kit to 15M is easily accomplished, I wanted to incorporate a few "enhanced-performance" modifications (most of which were gleaned from posts to the Internet QRP-L list) into an easily built, ugly-style version for the 15 M band. Some of these en-

hancements include: three-turn tuning pot, increased tuning range utilizing two varactors, increased RF power out using an MRF-237 final, adjustable transmit-sidetone level, and an integrated single-chip keyer. What follows is a brief but hopefully useful description of this process...a task easily undertaken by anyone with a few ordinary test instruments, some hand tools, a little soldering experience, and the desire to work the world on a watt or two with a completely homebrew rig.

Start by getting a copy of the original construction article (spring '97 issue of "QRPP"—NORCAL's quarterly publication—see parts below) and/or copy of the kit instructions, if possible. You will see that the heterodyne scheme of a 15 M. version sim-

ply uses a 25.0 MHz VXO (instead of an 18 MHz VXO as in the 20 M version) mixed with the 3.932 MHz IF (same as 20M version) to get you "there". The rig I built using two varactors tunes from 21.051-068 with a little overlap, and is dead stable.

The VXO and IF/BFO/transmit mixer crystals can be ordered from Digi-Key (see parts list) and the filter crystals matched using a simple crystal-checker circuit such as the one on page 25-6 of the '95 Handbook (a copy of the schematic is available from the ARRL). I used this circuit (just a couple of 2N2222s) with an inexpensive handheld frequency counter (Op-toelectronics 2810) to measure and match the three crystals for the filter. Out of the twenty IF crystals in the purchased lot, no less than four sets of three crystals were found to lie within 20 hertz of one another...making for some very fine Cohn filters when used with high-Q (read "mica" or "ceramic disc") capacitors. The remaining crystals were close enough to all be used in the BFO and transmit mixer with no problems. I cannot in good conscience guarantee that you will certainly have this good fortune buying closely-matched crystals, but similar results have been obtained a couple of times since with small lots from both Digi-Key and Mouser Electronics. I will venture a guess—that

if the crystals come out of the same box/batch it would appear that many may be quite closely matched at these frequencies (around 4 MHz). You have to take a little chance here... Throw in with a friend and buy 20 or so and see what you get...I have not been sorry yet, and there are four (40, 30, 20, 15 M) homebrewed SSTs sitting on the shelf...and the filters sound and work fine.

The construction method utilized consisted of 3/16" pads punched from single-sided PC board using an inexpensive sheet-metal punch available from a discount mail-order house (see parts list below). The punch comes with dies for holes/pads from 1/8" to 7/16" or so. The 3/16" size seemed to be about right for my purposes here and most other circuits as well. Ordinary household super-glue is used to secure the pads to the copper side of the circuit board in what some refer to as the "Manhattan" style of ugly-construction (I prefer to call it "grain-elevator" myself...). A little care must be used to avoid contamination of the copper surface with substances that will lessen the hold of the glue...a swipe of your favorite solvent/cleaner on the board where the pad goes will do. Methanol is my favorite (hardware-paintstripper/solvent). I used the liquid super glue and not the gel type, which seems to take longer to set up. One

small dot of glue will suffice. You have approximately three to five seconds before it sets after the pad is placed... so marking the spot on the board with a pencil AFTER you have trimmed and fitted the part leads and BEFORE the glue is laid ("dotted") is advice strongly recommended. The pads can be removed after the glue is set with a fairly sharp lateral blow, but the glue residue will not leave a pretty or level spot... a little layout planning is also highly recommended.

Once the pad is placed, a pencil eraser seems to make a very good "tool" to push and hold the pad to the copper for the few seconds it takes to set up, after which soldering can immediately take place. This construction method allows one to make quite compact and stable layouts since "grounds" are available everywhere. Try this method by first building the crystal checker on a small 2 x 2 inch or so piece of board to get the "feel" for it...it works great and further mods are simple and easy.

### **Construction Technique**

I used inexpensive low-profile machined-pin IC sockets throughout, including the keyern board. The pins are a bit longer than those of a leaf-type socket, and can be easily bent 90 degrees or so outward away from the socket (bent about ONCE,

although the pins will rotate before the IC is inserted). These sockets, unlike some leaf types, do not soak up any solder, and their cost is minimal at around 20-30 cents in small quantities (see parts list). I use this type of socket exclusively in my projects now...they are also sturdier as a general rule. After bending the pins outward at 90 degrees or so away from the socket center the socket can be mounted by simply soldering the bent-out pins to the pads at three or four corners. Unused pins can be removed with wire snips or a cut-off wheel mounted on a Dremel tool. Grounded pins are now just long enough to reach the board if left unbent. Also, the use of small gauge, tinned buss wire (20-24 gage) is a painless way to make many of those needed connections. Additionally, connections may be made by running wire underneath the IC sockets if necessary since there is a little bit of room there too. Most of the parts used here were from the usual sources, with a healthy dose of surplus parts from Dan's Small Parts. I used quite a few parts from Dan's which were on sale and collected as just general QRP-type parts over a period of several months while watching his website for bargains. Consequently, the cost of the rig was held fairly low in my particular case. The 15 M-specific and modification parts

are listed below, and the remainder can be found by part number and supplier in the kit instructions, if you happen to have a copy.

The layout of parts is not particularly sensitive, although a few general guidelines are worthy of consideration. The receiver section should be located near the front panel to minimize lead length from U1 to R1 (the RF attenuator) if you so choose to locate R1 on the front panel.

Likewise with the VXO circuit, mount it at the front of the board to keep the leads to the varactor switch as short as possible—millimeters DO count here. The varactors are mounted on the top and bottom of a DPDT mini-toggle switch so that the “up” position is the higher range and vice-versa. This means that the MVAM108 will be mounted on the topside of the switch. Keep all of the VXO parts leads short also.

The general layout uses as few jumpers as possible, the necessary wires including the control and input/output leads and a few runs of RG-174 from the VXO to the transmit mixer, the receiver mixer, and antenna jack. The ICs are powered by jumpers which run from the 78L08 regulator which might be located near the edge of the board to provide easy access due to the number of runs necessary. The 386 audio amp can

be powered directly off the DC input and through a 100 ohm resistor for a little more gain on audio peaks (hardly noticeable though).

The keyer board was mounted to the back panel and the peizo transducer for the keyer was mounted on the inside of the bottom of the enclosure near the front, under the board which was placed on quarter-inch standoffs.

The circuit can be built one IC at a time, while laying out the larger parts on the board for fitting before the pads are glued. Start with the regulator parts and then go on to the VXO. You can monitor the signal on your station's main transceiver to get it going.

Modifications to the original circuit were made to increase the transmitter output. These include the MRF-237 final, adding a 2.2uH choke between the final's base and ground, changing R10 from 180 to 120 ohms and, of course, increasing the DC input. I have seen over six watts output on my 'brewed 20 M version when I had a slight (!) power supply accident—a shorted voltage-adjustment pot in the power supply resulted in 25 volts going to the rig. The 237 final got VERY hot but it took the lickin' and kept on tickin'—although I don't recommend you try this much voltage unless you are very adventuresome, have a large heatsink, and some spare



parts... With these mods the rig puts out 2.5 watts at 13.8 V. and about 2.25 watts on a good gelcell into a reasonable load.

Also included in the mod list is the addition of two J305 FETs in the audio line which allow adjustment of the transmit sidetone (actually transmit monitoring). I found the level of the sidetone to be a little on the hearty side for my liking when it was necessary for the gain to be turned up at or near max. You can, of course, turn down the volume every time you transmit, or you can make this easy modification and use a 5 megohm trimmer to set the level to your fancy...it goes as follows: Place the FETs in the audio chain directly after the mixer (U2). They are in parallel, with one FET in each of the lines from pins four and five with the source leads toward U2 and drain leads on to C12 and C13. Tie their gates together and run a 2.2 megohm resistor from one (either) of the source leads to the now joined gates. This will hold the FETs open and conducting the audio signal thru the FETs as long as the rig is not keyed. Also place a .1uF cap from the gates to ground. Run a 5 meg trimmer across the source to drain leads of one of the J305s (again, either one) to "leak" a little of the signal around and past one of the FETs when they are grounded (and shut off) by the activated keyline. Then put

a 1N914 diode and 1000 ohm resistor in series running to the keyline with the non-banded end of the diode connected to the joined drains and the resistor running on to the keyline. Adjust the level via the trimmer to your liking.

This mod came directly from a post by Wayne B. and works FB, although it does slow down the QSK by a smidgen. You probably won't notice it much unless you're running over 35 WPM QSK.

One other substitution to the original circuit was made to allow precise adjustment of the BFO and transmit mixer. Two 60 pF trimmers were used at C10 and C24 instead of the fixed-value type. This will let you to adjust the BFO and transmit-off-set "right on the nose". These can be the same value/type trimmers as C1 and C28.

One other thing worthy of mention—If you do use a multi-turn pot for tuning, you will find the lack of an RIT circuit perhaps a bit less noticeable since it is now considerably easier to return to the same spot on the dial before transmitting. This is due to the fact that the band is now more "spread-out" and the exact position of the tuning knob now a bit less critical, making it much easier to "eyeball" it back to where it was before. You can also use a pencil, marker, etc. to make a line at this spot to re-

turn to, especially if you use a natural aluminum enclosure, from which any marks are easily removed with an eraser, solvent, etc.

As for board and enclosure size, the first SST built here (40 M) was considered a prototype (ain't they all?) and was assembled on a single-sided board 3 x 4 inches placed in a 5 x 4 x 3 Bud mini-box (-3005A, from Mouser). In this size of enclosure a pack of 8-10 AA batteries could easily be added. Subsequent models were built on 4 x 2.5 inch boards and mounted in 5.25 x 3 x 2.13 inch mini-boxes (-3006A) with considerably less room to spare.

Although the pad-and-glue construction method generally allows for very easy building and modification, this smaller board size made it occasionally necessary to remove a part or two just to get to the desired pad if it is necessary to go back and change something once the majority of parts had been mounted in a particular area. The iron used was an ordinary Weller WP30 with an ST1 tip. The board material came from the scrap bin at Surplus Sales of Nebraska. No copper ever came lose from the pads, even after repeated heating with this iron. It is certainly a simple, sturdy construction method, easily subject to individual "customizing" if desired. Parts can be mounted

both horizontally and vertically, as connections between ICs, and stacked... you can just go nuts!

Additionally, a pair of 5-6 inch forceps (also known as "hemostats" in the medical world) are invaluable in building with this method. If you lock the part in the forceps by a lead it can now be handled much more readily and held in the tightest of spots for soldering. Radio Shack sells these for around \$6-7, although the two pair I have purchased over the years from them don't seem to be of very high quality and I don't recommend those in particular. Electronic supply houses usually have these in the handtool section.

The keyer board can also be constructed using this same technique, employing your favorite flavor of keyer chip. In all versions built here it mounted easily on one side of the rear panel if all the in/out connectors are sized small enough and located on the other half of the rear panel. I used a BNC connector and 1/8 inch jacks, with a power jack similar to the type found on many of the popular QRP kits. These are available from Mouser in several styles with matching cords/plugs. PARTS:

Copies of "QRpp - 1997 Back issues" are available from Doug Hendricks, 862 Frank Ave., Dos Palos, CA 93620 Cost is \$15

(plus \$4 postage) and includes four issues in the volume—spring, summer, fall, winter. Make payment out to Doug Hendricks. The SST construction article is in the spring 1997 issue. There is a wealth of QRP info in each issue and it is WELL WORTH the bucks.

Hand punch for pads— Stock no. 37405-3NJH—\$16.99 phone orders: (800) 423-2567 <http://www.harborfreight.com>

Crystals-15 M. VXO: 25.0 MHz, Digi-Key (see below) stock no. CTX093-ND

1F: 3.932 MHz, Digi-Key, stock no. X013-ND

L2, L3-11 turns of #26 on T37-6 (yellow core)

C34, C36-150 pF silver mica

C35-270 pF silver mica

L1-18 turns of #26 T37-6

C27-30 pF ceramic NPO

RFC3—27 turns #26 on T37-2 (red core) — this may have to be varied, depending on the circuit and the tuning range desired—start with 28-30 turns

MRF-237\*—about \$9, available from RF Parts, 435 S. Pacific St., San Marcos, CA 92096 phone orders: (800) 737-2787 E-mail: [rpf@rfparts.com](mailto:rpf@rfparts.com) \*note on

MRF-237: the collector and emitter leads are reversed on this device, compared to the normal pin-out of the standard TO-5 package -install it backwards and IT WILL FRY! Use healthy heatsink.

three-turn potentiometer: Spectrol 533, 10K, stock no. 970-1830, \$12 from Allied Electronics, below

low-profile machined-pin IC sockets (8 pin): stock no. 151-308SGT, from Mouser, see below

Electronic Suppliers:

Digi-Key: (800) 344-4539,

<http://www.digikey.com>

Mouser Electronics: (800) 346-6873,

<http://www.sales@mouser.com>

Dan's Small Parts and Kits: Box 3634, Missoula, MT 59806-3636, phone/fax: (406) 258-2782

<http://www.fix.net/~jparker/dans.html>

Allied Electronics orders (800) 433-5700

<http://www.allied.avnet.com>

TICK keyer kits/ICs: Embedded Research, PO Box 92492, Rochester, NY 14692

<http://www.frontiernet.net/~embres>

72, de Mike K10AF

## The Fort Smith QRP Group P-TiCK Kit

by Doug Hendricks, KI6DS

ki6ds@hotmail.com

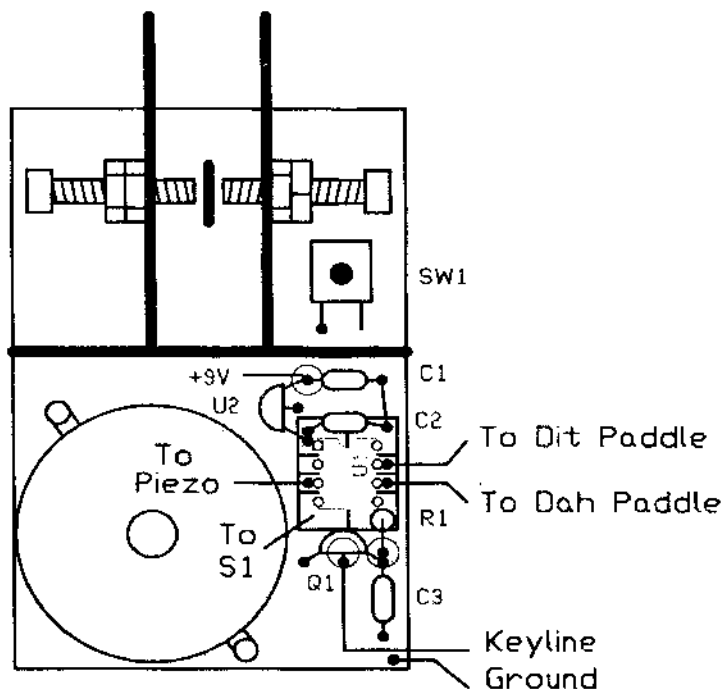

One of the up and coming QRP Clubs is the Fort Smith QRP Group. Last year they kitted the VE3DNL, and sold enough kits to put on an outstanding QRP Forum in April in Ft. Smith. They flew in the following speakers, Dave Gauding, NF0R, Doug Hendricks, KI6DS, Paul Harden NA5N, Jim Duffey, KK6MC, and Mr. VE3DNL himself, Glen Leinweber. It was an outstanding event and one that you will want to put on your calendar to attend next year. Jay Bromley, the leader of the group,

asked me to come up with another kit for them to sell this year and provide funds for ArkieCon 2001. By the way, ArkieCon has absolutely no connection to ARCI. The profits from this kit go towards the expenses of putting on the Ft. Smith Qrp Forum held every spring in Ft. Smith, Arkansas. I designed this kit with the idea being to produce a cheap, inexpensive paddle and keyer in the same package. The keyer part was easy, the TiCK from Embedded Research, naturally, but the hard part was the

paddles. I actually got the idea from seeing a paddle kit that was on the NorCal page designed by Wayne McFee, NB6M, and from a Manhattan style TiCK keyer that was built by Mike Fitzgibbon, N0MF in one of his homebrew rigs. I decided to change the single lever paddles to iambic and to put the TiCK keyer on the same board, and design it to fit into an Altoids tin. I succeeded, and we have a kit. The amazing thing is that the Ft. Smith QRP Group is selling a kit of parts to build the P-TiCK for \$10!! And that includes the TiCK-1 keyer chip. All parts, even the pcbboard parts are pre-cut for you. All you have to do is build it. This is a huge bargain, and it is a fun kit to build. Here are the details in case you want to roll your own, but I really think it is far easier to order the kit, plus you are supporting qrp.

#### **Parts List:**

##### **PC Board Parts:**

- 1 Base - 2" x 3"
- 2 Paddle Arms - 1/2" x 2"
- 1 Fence - 5/8" x 2"
- 1 Post - 3/8" x 5/8"
- 1 IC Carrier Pad - 5/8" x 5/8"

##### **Hardware:**

- 2 x 5/8" x 4-40 Stainless Steel Socket Head Screws
- 2 x 1/4" x 4-40 Zinc Screws
- 6 x 4-40 Brass Nut
- 2 rubber feet for paddle handles

##### **TiCK Keyer Parts:**

- 1 Tick Keyer IC, (8 pin DIP)

- 1 8 pin IC Socket
- 2 1uF tantalum or electrolytic capacitors
- 1 0.01 mono ceramic capacitor
- 1 4.7K resistor
- 1 2N2222 transistor
- 1 78L05 Voltage Regulator
- 30" 3 conductor computer ribbon cable
- 1 9V Battery Connector
- 1 Piezo
- 1 Switch

**Construction:** The kit includes all of the parts needed to build the paddles and the keyer. We will build the paddles first. You need a good soldering iron, with a chisel type tip that is 25 to 30 watts. Here is a diagram of the paddle kit parts.

You have a base, two paddle arms (not drilled), one fence (not drilled), one post, and one IC carrier board.

The first step is to make the cuts in the 5/8" x 5/8" IC carrier board with a hacksaw. Put the square piece (5/8" x 5/8") into a vise so that it is held by the edges, flat side is up, and gently close the vise to hold it. Make sure that you don't bend the board. Use the hack saw to gently cut just through the copper right in the middle of the board. Then turn the board 90 degrees and make another cut in the middle of the board. You will now have a board divided into 4 equal parts. Take the machine pin IC socket out of the parts bag and use it as a

.1" ruler to mark your next two cuts. Make a mark .1" on each side of the center cut as shown in the diagram. Be sure to cut very gently, and just go through the board. The idea is that you are making pads to solder the IC socket to. When you are finished, take an ohm meter and make sure that all of the pads are separate, and that there are no shorts between pads. The next step is to solder the IC

socket on the board that you have created. Line up the pins, and solder one corner, then the opposite corner, then the third and finally the last. Then solder the inside pins. Be careful here. If you apply too much heat you will melt the socket. Be quick, yet make sure you have good solder joints.

You might be tempted to not use the socket, but it is important that you do, as it will allow

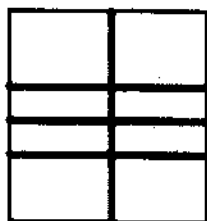

## IC Carrier Board

Hacksaw cuts to separate copper on both sides

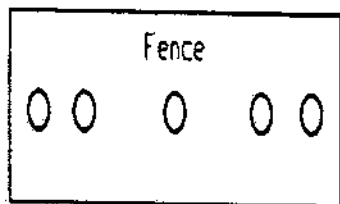
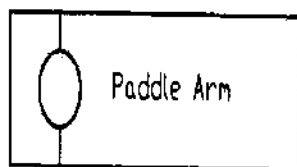

you to upgrade your keyer to one with a memory should you choose to do so. The machine pin sockets give extra stability and were chosen because of this. When you finish soldering the socket, set it aside for now.

Next we will build the paddle portion of the kit. It is easy to do and the secret is to use enough heat to get good solder joints.

**Step 1:** Find the post, which is a 3/8" x 5/8" piece of double sided pcboard. Use the special silver solder that was in your kit and use it to put a "blob of solder" on each side of the post. The special silver solder will give you better contacts than the normal solder you usually use. Run a nice bead from the top to the bottom of the post. The post will be soldered so that the base is 3/8" wide and it is 5/8" tall.

**Step 2:** Solder the post to the main board putting it right in the middle and about 1/4" in from the edge. Make sure that it is straight. Run a bead on both sides of the board. Set the main board assembly aside.

**Step 3:** It is time to drill the access holes for the cables in the fence. You will note in the drawing on page 1 that the fence has 5 holes drilled in it. Use a 1/8" bit and drill the five holes as indicated in the drawing. Be care-

ful and use a set of pliers to hold the piece as you drill it so you won't be injured if the bit catches the board and causes it to spin. Finish up by using a 1/4" drill bit to deburr the holes by hand.

**Step 4:** After you have drilled the holes, it is time to prepare the paddle arms for assembly. There will be two holes in each paddle arm, and we will drill the first one now. Find the center of the paddle and draw a line the length of the paddle arm through the center. Measure 5/16" from one end and put a mark. This is the location of the big hole. Drill it out first using a 1/8" drill bit, then use a 1/4" bit to finish the hole. Be careful and hold the pcboard with a pair of pliers, not your bare hands, in case the bit "grabs" the board. Drill the other paddle arm as you did the first. Take a hacksaw and very gently make the cuts shown in the diagram on page two. The purpose is to separate the rest of the paddle arm from the base. Make the cuts on both sides of the hole. Now flip the arm over and do the other side of the arm. Now do the other arm in the same manner.

**Step 5:** Now it is time to solder the paddle arms to the fence. To do this, you will need a small "C" clamp and a 1/2" nut. Go to any hardware store and buy 1 nut. Make sure that it is not only

$\frac{1}{2}$ " in size but that it is  $\frac{1}{2}$ " in thickness too. You will be using the nut as a spacer to set the distance between the paddle arms and to keep them parallel. Take each arm and put them on either side of the nut so that the arms cover the hole in the nut. Then use the "C" clamp to hold them while you check to make sure that they are square and even. This is very important to the proper alignment of the paddles. When you are sure that the arms are even and square, place them in position on the base that you soldered the post to and check for alignment. If you have the post exactly in the center, the arms will also be in the center. Solder them to the fence so that they are equal distance from the post. Also, make sure that one edge of the arms are even with the edge of the fence. This will be the top of the paddles when you mount it. The fence is  $\frac{5}{8}$ " wide and the paddle arms are  $\frac{1}{2}$ " wide, this was done to give you  $\frac{1}{8}$ " of clearance with the paddles.

**Step 6:** Next we will drill the second set of holes in the paddle arms for the contacts. Set the fence/paddle arm assembly on the base and line it up. Let the handles stick over the edge by  $\frac{1}{2}$ ". Mark the paddle arm where it is in the middle of the post. This is where you will drill a  $\frac{1}{8}$ " hole for the contacts. Put the

$\frac{1}{2}$ " nut back in between the arms so that it will help support the arms, and use a drill press to drill the hole. It will make sure that the two contact screws line up properly. You can drill the holes with a hand drill, but make sure that you drill straight and true.

**Step 7:** Find two of the 4-40 brass nuts and a stainless steel contact screw, the 4-40 x  $\frac{5}{8}$ " screw with the socket head. Mount the screw in the hole you just drilled in the paddle arm using two nuts, one on the outside of the paddle arm and one on the inside. Tighten them finger tight and then solder the outside nut only to the paddle arm. Be careful to not get solder in the threads, and make sure that you use the stainless steel screws provided. Put solder all the way around the nut. Repeat the operation on the other arm.

**Step 8.** Let's align the paddles and check to make sure that they will fit in an Altoids tin if you wish to store them in one. Set the fence/paddle arm assembly on the base, then put the base in an Altoids tin. The paddle handles should stick over the end of the base by  $\frac{1}{2}$ ". Mark the base where the fence should be. Then draw a line with a square on the base and use it as a guide to solder the fence to the base. Be sure to double



check that every thing is square, and that it will fit in the Altoids tin. Solder both sides of the fence. I usually tack one corner, then the other corner on the same side and check with a square to make sure it is perpendicular to the base. Make any adjustments needed, and then tack the corners on the other side of the fence. When you are certain it is square, then you can finish soldering.

**Step 9:** Mount the two contact screws in the arms by first putting a brass nut on the screw and then inserting the screw in the soldered nut. The paddle assembly is now finished.

**Step 10:** Find the piezo. It is the round black thing that looks like a speaker and has two tabs on it for mounting. Use the drawing on page 1 as a guide, and place the piezo where it goes. Line it up, making sure that it does not overlap the edges. Use a pen or pencil to mark the center of each tab, and then drill each hole using a 1/8" drill.

**Step 11:** Take two 4-40 screws and put them in the holes you drilled from the bottom of the board. Place two 4-40 brass nuts on the screws and hand tighten. Then solder each nut to the top of the board. They will become standoffs to use to mount the piezo later. When the

solder cools, remove the screws.

**Step 12:** Use superglue to glue a round pad where U2 and C1 connect. Tin it with solder. Solder C1, the 1uF tantalum or electrolytic capacitor to the pad and to ground. Make sure that the positive lead of C1 goes to the pad.

**Step 13:** Solder C2, a 1uF tantalum or electrolytic capacitor to the end of the IC mother board at the end of the IC socket. The positive lead goes to pin 1, the negative to pin 8. Solder a piece of component lead from pin 8 pad to ground as shown.

**Step 14:** Superglue the IC mother board down in the position shown.

**Step 15:** Find U2, the 78L08 and solder it in. Orient it as shown on the parts layout. The three leads go to Pin 1 of IC1, ground, and pad 1.

**Step 16:** Superglue 2 more pads near pins 4 & 5 of the IC pad as shown. Tin them with solder.

**Step 17:** Solder R1, the 4.7K (yellow-violet-red) to pin 5 pad and the outer pad that you just glued down. It is mounted vertical to save space.

**Step 18:** Solder C3, the blue .01uF cap to the pad and to

ground as shown.

**Step 19:** Solder the 2N2222 (may be marked (PN2222, PN2222A, or 2N2222A) transistor in the orientation shown. The left lead goes to ground, the middle lead to the left pad and the right lead to the outer pad.

**Step 20:** You have a piece of 3 conductor gray ribbon cable in your kit that is 30" long. Cut a piece from it that is 4" long. Separate 1 conductor from the other two of the short piece so that you have 1 conductor 4" long, and 2 conductors 4" long. Put the 1 conductor wire with the rest of the parts. You will use it in Step 24. Prepare the ends of the wires by carefully stripping the insulation back about ¼". Solder one conductor to pin 6 of IC1 and the other wire to pin 7 of IC1. Run the cable through the middle hole of the fence, and split the cable, attach the wire from pin 6 to the dah paddle, and the wire from pin 7 to the dit paddle. Solder the wires to the outer sides of the paddle arms. There is no need to run a ground wire, because the paddle shares a ground with the IC. The usual convention is to use the right paddle arm as the dah, and the left as the dit.

**Step 21:** Take the long piece of 3 conductor ribbon cable. Solder one conductor to the center

lead pad of Q1, and the other to ground. Run the cable through the second hole on the right side of the fence, and then back through the first hole. This will act as a strain relief. Take most of the slack out of it.

**Step 22:** Run the two wires from the 9 volt battery connector through the left hand hole of the fence from the piezo side. Thread it back through the adjacent hole and then solder the red wire to the +9V pad that C1 and U2 are soldered to. Solder the black wire to ground.

**Step 23:** Now take the piezo and trim the leads to about 2" long. Solder the red lead to pad 3 of the IC carrier board, and the black lead to ground. Place the piezo in position and attach with two 4-40 screws.

**Step 24:** Find switch 1. It is designed to be mounted upright on a pc board. Cut the pcboard tabs off. Place the switch as shown on the drawing. Solder the case to the board and the left lead to ground as shown. Take one conductor of the ribbon cable left over from Step 20 and solder one end to the other switch connector, run the wire through one of the access holes, and then solder the other end to pin 4 pad of IC1.

**Step 25:** Solder the mono 1/8"

plug to the other end of the keyline. Make sure that you get the positive lead to the tip, and the ground lead to the case.

**Step 26:** Hook up a 9 volt battery to the 9 volt connector. Use a VOM and check to see that you have around 5 Volts at pin 1 of IC1. Do this before you insert the IC. If the voltage checks out, unhook the battery, and insert IC1, making sure that you align pin 1 of the IC as shown in the diagram on page 1. The notch of the IC goes towards the fence. Do not insert the IC with the battery connected. You should hear 3 beeps when you hook the battery back up. Adjust the contact screws for the best feel to you, and you are ready to go. The volume of the piezo is not very loud. It is used to program the keyer chip as explained on the chart on the next page. If you have problems, go back and check for proper connections and that there are no shorts or solder bridges. The circuit is straightforward and should be

easy to debug. If you need more help, contact Jay Bromley at [w5jay@alltel.net](mailto:w5jay@alltel.net) or

Jay Bromley  
9505 Bryn Mawr Circle  
Ft. Smith, AR 72908

To order a complete set of parts to build the Ft. Smith P-TiCK, send \$10 for the kit, yes that is correct. The cost of the kit is only \$10 and that includes all parts, precut pcboard stock, and even the TiCK-1 Keyer chip. Please add \$2 shipping and handling for the US & Canada, \$4 for Europe and \$6 for the Pacific rim countries. Send your order to:

Jay Bromley  
9505 Bryn Mawr Circle  
Ft. Smith, AR 72908

Please make checks or money orders to Jay Bromley. Also please enclose a self addressed mailing label. Thanks for your support.

## TiCK Operating Instructions

ACTION	TICK RESPONSE	FUNCTION SW1 Released
Press SW1	"S" (dit-dit-dit)	<b>SPEED:</b> To adjust speed: press DIT paddle to decrease, DAH paddle to increase
Hold SW1 Down	"T" (dah)	<b>TUNE:</b> To end tune-up, press either paddle or SW1 again
Hold SW1 Down	"P" (dit-dah-dah-dit)	<b>PADDLE:</b> Press the paddle you want to designate as the DIT paddle. Default : DIT = tip of stereo jack
Hold SW1 Down	"A" (dit-dah)	<b>AUDIO:</b> Press the DIT paddle to enable sidetone, DAH paddle to disable. Default: enabled.
Hold SW1 Down	"SK"	<b>STRAIGHT KEY:</b> Pressing either paddle toggles the TiCK between Straight Key and Keyer Mode. Default: Keyer Mode.
Hold SW1 Down	"M"	<b>MODE:</b> Pressing the DIT paddle puts the TiCK into lambic Mode A, DAH paddle puts it into lambic Mode B. Default: lambic Mode B
Hold SW1 Down	"K"	<b>KEYER:</b> If the user releases the pushbutton, keyer returns to normal operation
Hold SW1 Down	"S"	<b>SPEED:</b> Cycle repeats with speed adjust.

Embedded Research, in Rochester, NY sells an upgrade chip for the Ft. Smith QRP Group Paddle/TiCK keyer kit. It is called the TiCK 4 and has several outstanding features. Order an upgrade today. Be sure and mention that it is for the Ft. Smith Project. You can visit the Embedded Research site on the

Web at:

<http://www.frontiernet.net/~embres/>

There you will find full details on all of their outstanding products. The TiCK-4

Embedded Research is pleased to announce the newest mem-

ber of the TiCK keyer family, the TiCK-4. The TiCK-4 offers all the features of the TiCK-1, TiCK-2, TiCK-2B, and TiCK-3, plus it offers non-volatile parameter memory! All this in the familiar TiCK 8 pin footprint.

We are committed to bring amateur radio enthusiasts the smallest, most feature-packed keyers. "If you can find a better keyer, buy it!"

#### Summary of TiCK-4 Features

- Two 50 character, user programmable message memories
  - NEW! Non-volatile parameter memory, means no more resetting speed, mode, and other settings after power cycling the TiCK! You can configure the TiCK-4 to you personal settings, and they will remain in effect until YOU change them!
  - Pin-for-pin compatible with all other TiCKs (TiCK-1 / TiCK-2 / TiCK-2B / TiCK-3)
  - Maintains the familiar and simple TiCK user interface
  - Single Pushbutton Interface (SBI) to all functions
  - Upgrade your TiCK keyer by simply plugging in the TiCK-4... It's that easy!
- #### Complete TiCK-4 Feature List
- Two 50 Character user programmable message

- memories
- Non-volatile parameter memory
- Speed Adjust (via paddles)
- Tune Function
- Paddle Select
- Sidetone (ON/OFF)
- Iambic Modes A & B
- Straight Key Mode
- Beacon Mode
- Low Current Consumption (1 uA in sleep mode)
- Requires 3-5V DC
- Uses the very latest in RISC-based microcontroller technology
- Currently available in 8 pin DIP package and 8 pin SOIC.

We are offering the TiCK-4 as follows:

- TiCK-4 Chip + Datasheet, \$15.00, (S/H for CONUS \$2.50, DX \$5.00)
- #### Payment Information
- We do not at this time accept credit cards - send checks and money orders only!
  - For DX orders, an international money order is best.
  - All payments must be made in U.S. dollars
  - Send orders to:  
Embedded Research  
PO Box 92492  
Rochester, NY 14692

## An Improved LED SWR Indicator

by Glen Leinweber, VE3DNL

For rugged portable use, or for sheer simplicity, it's hard to beat a light-emitting diode as an indicator of reflected antenna power (SWR). Figure 1 shows a simple absorptive SWR meter. When SWR is low, the LED emits no light. Sensitivity is poor, meaning that before light is visible, SWR is already fairly high. A low-power transmitter magnifies this problem. Adding a current transformer improves performance at low input power, and extends high power range too.

### Circuit Operation

Transmitter power comes into a standard four-resistor bridge circuit, where the antenna load substitutes for one bridge arm. Component values for the remaining three resistors are chosen so that the transmitter will see a 50-ohm load (if the antenna is 50 ohms too). This arrangement has the added advantage that the transmitter will see a fairly reasonable load, even when antenna impedance is wildly off. Worst case SWR that the transmitter will see (when the antenna port is open-circuit) is 2:1. There is a price to pay: only one quarter of transmitter power will reach a 50-ohm antenna load. Once you check the SWR, this circuit should be removed or switched out of the way, else you'll be at a -6 dB disadvan-

tage.

The light-emitting diode puts out light that is proportional to forward current passing through. A high-efficiency LED will start to become visible (in a dark environment) with as little as 50 microamps current. However, current doesn't begin to flow until it is forward-biased about 1.5 volts.

Operating current for the LED comes from the high amplitude radio frequency power coming in from the transmitter. When antenna impedance is either higher or lower than 50 ohms, RF voltage across the bridge arms rises. This RF voltage must be rectified with a diode, since the LED only emits light when its anode is more positive than its cathode. The LED would rectify the RF itself, but not efficiently. A germanium diode or schottky diode helps in this circuit. When the antenna impedance is far enough from 50 ohms to give more than about 2v peak-to-peak across the bridge arms, rectified voltage across the LED is above 1.5 volts, and the LED begins to glow.

The "dead zone" below 2v p-p results in the sensitivity problem. A test with a 2.7 watt transmitter was made to see how high the SWR had to rise before the

LED glowed visibly. For SWR below 1.3:1 no light could be seen. With the antenna short circuited (infinite SWR), the LED was blindingly bright.

### Improved Circuit.

To improve SWR sensitivity, the RF voltage across the bridge arms should be made larger. A broadband RF step-up transformer is required (figure 2). When the 1:10 ratio step-up transformer was added, the same sensitivity test was run. For SWR above 1.06:1 light could be seen.

But what about really high SWR - won't the LED burn out from too much current? No, you actually get less light. With lots of LED current flowing, the RF impedance of the primary winding is very low. It is much lower than the resistive bridge arms. Because of this impedance mismatch, less RF power is transformed into LED power. The LED should survive infinite SWR, even when driven from a full teaspoon (5W transmitter). The LED in this circuit can withstand more RF power than in the simple circuit of figure 1.

### Building the circuit.

Since 50 ohms is not a standard resistor value (nearest is 51 ohms), two paralleled 100 ohm half-watt carbon film resistors were used in each bridge arm. Since each bridge arm must

consume one quarter of transmitted power, you should expect these resistors to get warm. Three 150 ohm resistors in parallel would also work well - allow a little air space around each. Be suspicious of resistors having a power rating of 5W or more: chances are good that they're wirewound - inductance is not desirable. Carbon composition, carbon film or metal film resistors are fine. The arrangement shown should handle a 5W transmitter, if transmitted power is limited to 20 second bursts.

Any germanium point contact diode similar to 1N34 can be used for the rectifiers. A schottky diode is fine too (1N5711). A silicon diode like 1N914 or 1N4148 will work, but sensitivity will suffer a little.

Try to find a high-efficiency light emitting diode. LEDs have improved greatly in recent years; older diodes are significantly dimmer. Red is preferred to any other colour, since red LEDs will start to emit light at lower forward voltage - this helps the sensitivity problem. I find that "water clear" plastic lens material is better than "diffused." Avoid LEDs incorporating series resistors. A good-looking LED (from the Digi-Key catalog):  
T 1 3/4 SUPER BRIGHT WATER CLEAR RED (LITEON) LT1102-ND, or LT1103-ND or LT1104-ND.

For any portable operation,

this 50-ohm SWR indicator is simple, robust and inexpensive. It should work well at any frequency from 3 to 30 MHz, and is optimized for transmitter power in the half watt to seven watt range. While you can't ac-

tually measure SWR, you can check that your antenna is good, or you can adjust an antenna tuner for best match. It's a simple circuit that only takes an evening's work

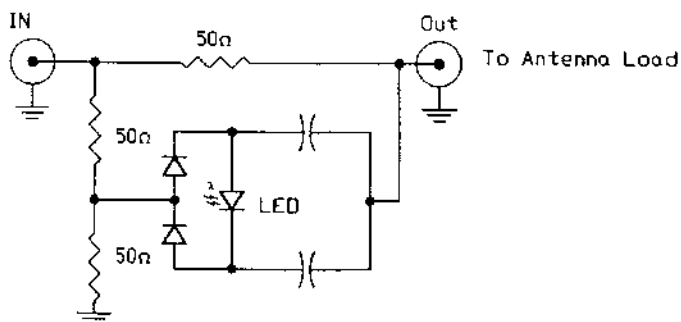

Fig. 1 Simple but insensitive

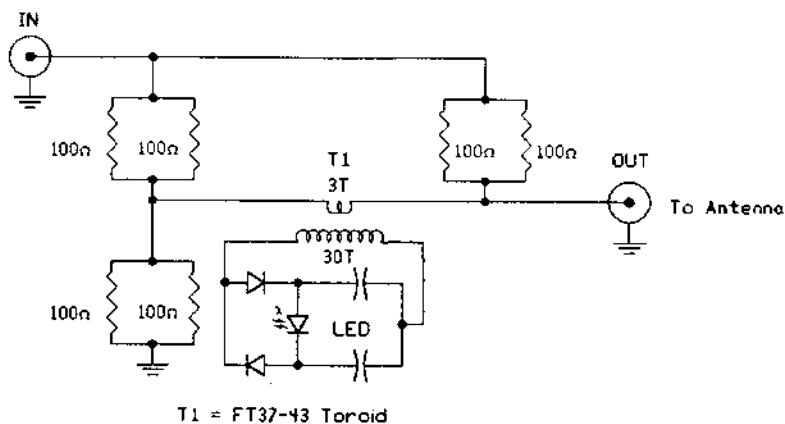

Fig. 2 Sensitive SWR Indicator



## A Microphone Preamp For The Elecraft K2

by Jerry Haigwood W5JH

### Introduction

The K2 is the best thing that has happened to QRP in a long time. Eric Swartz, WA6HHQ and Wayne Burdick, N6KR (owners of Elecraft) had sold over 750 radios by the end of 1999. To say the K2 is a popular radio would be some what of an understatement. The philosophy of Elecraft and the K2 is also very different from any other manufacturer. Elecraft invites you to experiment and modify the radio (see chapter 9 of the K2 manual). How many manufacturers would allow you to modify your radio and still warranty the unit? It is in this spirit that this article is written.

Some people have reported low transmit audio while using the Elecraft SSB unit for the K2. It appears that the K2 SSB unit was designed for a dynamic microphone with a reasonably high output. Some users have tried using electret or similar microphones with lower output without good results. What is needed is a microphone preamp.

### The Mechanical Design

This microphone preamplifier is very small and was designed to not only work with the Elecraft K2 transceiver but with many microphones that need a "boost" in their output. This

preamp was designed to fit INSIDE the K2 using the microphone configuration connector P1 as a "holder" although this preamp is small enough to fit into many microphones. There are sixteen pre-drilled holes on the circuit board allowing the preamp to slide onto the K2 microphone configuration connector. The preamp is held in place by configuration jumpers and wire wrap points. If you decide to mount the preamp inside of a microphone, you can cut off the 16 holes to reduce the board size.

### How it Works

The microphone preamp is a single transistor amplifier in a common emitter configuration. Resistors R1 and R2 are used to bias the transistor. Input impedance of the amplifier is on the order of 1700 to 2300 Ohms depending on the value of R2 and R4. This is a good match for low impedance microphones. The collector resistor 1K Ohm was chosen as a good match for the K2 microphone input circuit. The voltage gain of this amplifier is approximately R3 divided by R4. Several values of R2 and R4 are shown to set the gain to the desired value. The input and output are coupled using small tantalum capacitors.

## Programmable Gain Resistors

This preamp uses a programmable gain feature. This is accomplished by changing the value of two resistors. Before mounting R2 and R4, you must decide how much gain your microphone needs. It is best to start with the smallest amount ( $A_v=3$ ) test it and determine if you are satisfied with the results. Some of the things that will affect your gain choice are:

- Can the VOX be triggered and held in a normal voice?
- Can full rated output be had (10 watts)?
- Can any distortion be heard?

If you can already hold the VOX in on the K2 while speaking in a normal voice, you do not need any more microphone gain. The K2 VOX circuitry seems to require a slightly higher level than the level required to produce full RF output. It is a good indicator that you have enough microphone gain. When selecting gain, start with the lowest gain ( $A_v=3$ ) try it out and get several reports. Try to hold the VOX in a normal voice. If you can, you are finished, else continue increasing the gain until you can hold the VOX in and there is no distortion on your signal. Note: Make sure you have SSBA set to 2 or 3!

## Getting The Parts

The Arizona ScQRPIons QRP Club is making a kit available. To order send \$10 for a complete parts kit and a pcboard to:

Bob Hightower  
1905 Pennington Drive  
Chandler, AZ 85224-2632

The sources mentioned here are where I obtained the parts for the prototype. Mouser Electronics (800) 346-6873 can supply the 2N4401, all of the 1/8 watt resistors and the two tantalum capacitors. Your local Radio Shack store has wire wrap supplies including a wire wrap tool and wire. Radio Shack also has proto boards which can be used to build this preamp.

## Building Instructions

This preamp can be built using several techniques. A proto board with holes and copper rings every 0.1 inch can be used and was used during the development phase. If you are good at making PC boards, an etching pattern is provided. This board is quite small (less than 1 square inch) and fits into the K2 nicely.

The following instructions assume you are building the preamp using the PC board shown. However, the same instructions can be used if you are using the proto board mentioned

above. Note: all parts for the preamp are soldered on the trace or foil side of the PC board. No holes for the components are provided. The parts are mounted "surface mount" style. Each lead is tacked down with solder using a low wattage soldering iron with a small tip. A magnifying glass and lamp will help identify each component.

1. Identify and inventory each part before proceeding.

2. Place the PC board in front of you with the trace side up and the holes to the right side. Using the Parts Placement guide, install Q1 first. Q1 has a flat side (face) and a rounded side. Place the flat side face down against the PCB with the leads protruding to the left. Bend the leads to lay flat on the board and trim the length to allow soldering but not allowing shorting. Solder the leads to the 3 traces shown.

3. Locate R1 and R3. Bend the leads so that the resistors will lay flat against the board and trim them to fit the correct pads. Solder the leads.

4. Locate the programmable resistors R2 and R4 which you have selected. Bend the leads so that the resistors will lay flat against the board and trim them to fit the correct pads. Solder

the leads.

5. The capacitors C1 and C2 are mounted on their side with the capacitor body protruding to the left away from the 16 holes. Bend and trim the leads. Insure you have the correct polarity before soldering the leads.

6. Inspect the board under a magnifying glass and strong lamp. Check for shorts, unsoldered leads, etc.

### **Mounting Instructions**

If you are mounting the preamp into a microphone, you only need to connect +5 volts, ground, input, and output. The mounting choice will be yours. Take into account shorting problems when selecting a mounting method. Double sided foam tape works well especially in hand microphones where everything is held tight by tightening the case screws. If you are mounting the preamp into the K2, use the following instructions.

The Elecraft K2 uses a 16 pin header (P1) for microphone configuration. For these instructions, the pins will be labeled K2-1 through K2-8 on the Elecraft side of P1 and MIC-1 through MIC-8 on the Microphone side of P1. Six wires are used to connect the Preamp to the K2.

These wires are connected using wire wrap techniques. The

preamp can easily be removed at a later date - no permanent changes are made.

1. Prepare six wires of insulated #28 or #30 wire by cutting each wire 2.25 inches long. Strip 1 inch of insulation from one end of each wire. Strip 0.1 inch from the opposite end of each wire.

2. Using two of the prepared wires, twist the 0.1 inch bare ends together and solder them to the +5V pad.

3. In a similar manner, twist and solder two wires to the GND pad.

4. Solder the 0.1 inch end of one of the remaining wires to the INPUT pad.

5. Solder the 0.1 inch end of the last wire to the OUTPUT pad.

6. In order to Install the preamp into the K2 you must first: remove the Top Cover, remove the Control Board, and remove the Front Panel Assembly. Lay the Front Panel Assembly face down on a soft cloth with P1 toward the right. Remove any jumper wires on P1 (Note: If you soldered wire onto P1, you will need to remove all solder before trying to mount the preamp). Slide the preamp board over P1. Make sure the preamp board protrudes to the left of P1. The friction of the 16 holes/pins along

with the wire wrap leads to be placed on the pins are used to hold the preamp in place. Once the preamp is in place, choose the following instructions which match up to your microphone type.

### **KENWOOD**

For a Kenwood type of microphone (as defined in the Elecraft SSB manual page 16), use the following instructions:

Make the following connections using a wire wrap tool:

Preamp +5V pad to K2-6  
Preamp +5V pad to MIC-5  
Preamp GND pad to K2-7  
Preamp GND pad to MIC-7  
Preamp INPUT pad to MIC-1  
Preamp OUTPUT pad to K2-1

Configuration jumpers should be used to connect:

K2-2 to MIC-2  
K2-3 to MIC-3  
K2-4 to MIC-4  
K2-8 to MIC-8

### **ICOM**

For a Icom type of microphone (as defined in the Elecraft SSB manual page 16), use the following instructions:

Make the following connections using a wire wrap tool:

Preamp +5V pad to K2-6  
Preamp +5V pad to MIC-2  
Preamp GND pad to K2-7

Preamp GND pad to MIC-7  
Preamp OUTPUT pad to K2-1  
Preamp INPUT pad to MIC-1

(See Elecraft manual about connecting a resistor from this pin to +5V. The resistor can be mounted on the preamp board.)

Wire Wrap can be used for the following connections:

K2-8 to MIC-6  
K2-2 to MIC-5

A configuration jumper can be used to connect:

K2-3 to MIC-3

## **YAESU**

For a Yaesu type of microphone (as defined in the Elecraft SSB manual page 16), use the following instructions:

Make the following connections using a wire wrap tool:

Preamp +5V pad to K2-6  
Preamp GND pad to K2-7  
Preamp GND pad to MIC-7  
Preamp INPUT pad to MIC-8  
Preamp OUTPUT pad to K2-1

Wire Wrap can be used for the following connections:

K2-8 to MIC-2  
K2-2 to MIC-6  
K2-4 to MIC-1

A configuration jumper can be used to connect:

K2-3 to MIC-3

Some Yaesu microphones require +5V on MIC-5. However, the wiring diagram for the Yaesu MD1 microphone shows pin 5 as GROUND. Investigate your microphone diagram thoroughly before connecting +5V to this pin. If +5V is not required by your microphone, then remove the extra +5V wire wrap lead.

## **Testing**

The preamp is best tested using the criteria outline above (choosing the programmable resistors). It is best to listen to yourself on a second receiver while transmitting into a dummy load to determine the effect of the preamp.

## **Removal**

The preamp can be easily removed. Just remove the configuration jumpers, remove the wire wrapping, slide the board off. You will then need to reconfigure the microphone interface (P1).

# A Microphone Preamp For The Elecraft K2

## Schematic

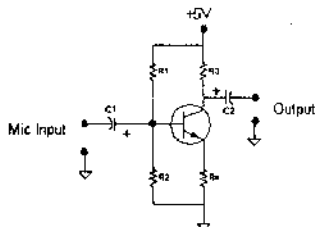

## Parts List

C1, C2	6 8uF/16V Tantalum Capacitor
Q1	2N4401 Transistor
R1	10K 1/8W 5% Resistor (BRN-BLK-ORG)
R2	See Gain Table
R3	1K 1/8W 5% Resistor (BRN-BLK-RED)
R4	See Gain Table
PCB	Small Printed Circuit Board

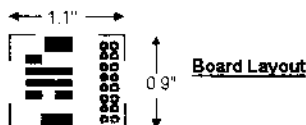

## Gain Table

Gain	R2	R4
3	3.9K 1/8W 5% Resistor (ORG-WHT-RED)	330 1/8W 5% Resistor (ORG-ORG-BRN)
4.5	3K 1/8W 5% Resistor (ORG-BLK-RED)	220 1/8W 5% Resistor (RED-RED-BRN)
6.6	2.4K 1/8W 5% Resistor (RED-YEL-RED)	150 1/8W 5% Resistor (BRN-GRN-BRN)
8.3	2.4K 1/8W 5% Resistor (RED-YEL-RED)	120 1/8W 5% Resistor (BRN-RED-BRN)
10	2.4K 1/8W 5% Resistor (RED-YEL-RED)	100 1/8W 5% Resistor (BRN-BLK-BRN)

## Parts Placement

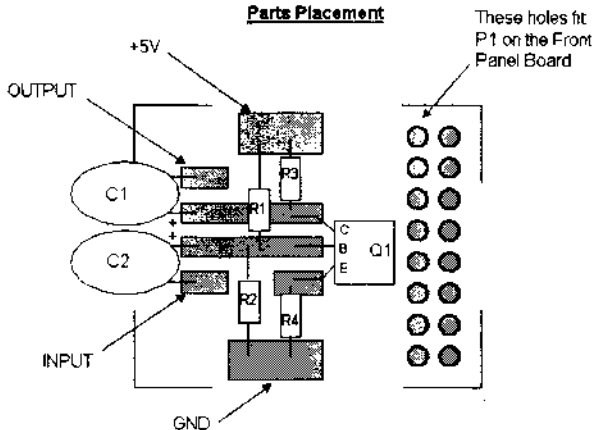

## Operating News

By Richard Fisher, KI6SN  
1940 Wetherly Way  
Riverside, CA 92506  
(909) 369-8302  
KI6SN@yahoo.com

### 'VY 72' TO ALL

The first order of business in this quarter's edition of Operating News is to thank all of you who took the time and energy to send your kind letters of support following the debut of QRPP's newest column in last quarter's edition.

"Vy 72" to you all.

One of the finest attributes of the QRP community is the wonderful support it has given to efforts such as this. You may suspect that some columnists take this kind of thing for granted. I can assure you that, as one who has covered the QRP scene for many, many years, this columnist doesn't.

Thank you very, very much.

And here's hoping that you keep those cards, letters and e-mails coming in. Sharing your successes, failures and challenges with the rest of QRPP readers enriches the low power experience for us all.

And now I yield the floor to you...

- R.E.F

### WHY NOT GIVE 12 A TRY?

Randy Foltz, K7TQ, writes from Moscow, ID, that on Feb. 12, he "gave 12 meters a try. First at 2338 Z I worked JN1NOP using 2 w. He was 559 and gave me a 539. Japan to Moscow, ID is around 4,800 miles depending where in Japan, so this was over 1,000 miles per watt.

"I thought that sure was easy, so I turned the K2 down to 900 milliwatts and gave JA1OSN/7 a call at 2348 Z. He was 579 and gave me a 559.

"Now I had about 5,000 miles per watt. Down went the power again to 500 milliwatts and at 0001 Z Feb 13 I gave JA8BGR a call.

"He got my call first time around and gave me a 559 to his 589. This one was 8,990 miles per watt.

"Now I wanted 10,000 miles per watt, so down went the power to 200 milliwatts. Again I looked for strong station and found JN2QYN/2 calling CQ at 0012Z.

"He also got me on the first try and gave me a 339. He was 579. This was good for about 25,700 miles per watt.

"Each of these powers were at initial call up. Those guys sure did have good ears!

"Each will get a QSL and a 1,000 miles per watt certificate. For those who are interested, my antenna is a GAP Titan. Most of the JAs reported 4 or 6 element yagis. Give 12 meters a try. It can be a great QRPP band."

### A MYSTERY RADIATOR, INDEED

Caity Martin, KU4QD, writes from Morrisville, NC, that "I was on 15 meters recently with my newly re-acquired NCG 7/21/50.

"And despite fairly good band conditions, I was getting fairly poor signal reports with my vertical.

"I had tried working my friend Dave in Colorado, and we couldn't make a go of it.

"There was a Girl Scout special event station on from Dallas, and I decided to forsake QRP and use my 20 watt Tokyo Hy-Power monobander (that is QRO for me), and after talking to a couple of the girls, I faded out on them.

"As a woman in ham radio I really wanted to encourage them, so this was really frustrating.

"Clearly, I needed to do better, and besides, Dave wanted to try later on 40, and my vertical antenna is terribly inefficient there. So... it was time to string a new wire antenna.

"At Dave's suggestion, I ran a length of wire down from my antenna tuner's ground post to a water pipe.

"We knew this would radiate, since I

live upstairs, so it would act at least as much as a counterpoise or as a part of my antenna as a ground.

"Anyway, the remainder of my spool of wire (which also was used to make little radials for my six meter vertical) was thrown up into the trees, and my original thought was that I was doing an end fed long wire.

"As it turns out, this was not quite true.

Anyway, Dave was able to hear me FB with 10 watts on 40, but I was having an awful time trying to hear him.

"A station in Ohio could hear both of us just fine, but that would never do. It was almost two hours after local sunset, but I asked Dave to stand by and flipped back to 15.

"There weren't many signals, just the usual Latin American 'kilowatts' and a few others, but I decided to try anyway.

"Sure enough, well into the evening, we were both enjoying beautiful armchair copy on 15.

"So, what went right? There was approximately 66'-67' of wire left, as it works out, and we all know that is a quarter wave on 40.

"I think what we made here is some kind of weird, off-center fed dipole, one part vertical, one part sloping upwards from the feed point on the second story to a peak maybe 35' up.

"I'm not sure exactly what it is or why it works, but signals are at least three S-units above the vertical on both 15 and 40, and it is pretty well resonant on both bands.

"I'll see how well it tunes up on 10 and 20 next. The antenna tuner should be able to handle it, no matter how weird a load I am presenting (it), anyway.

"The question is whether it will be at all efficient on other bands. I suspect it will act as a true long wire on 10, and that should be OK.

"So . . . look for me to have stronger signals from now on.

"The moral of the story: even in an apartment environment, something will

work, even at QRP power levels, and it sure doesn't take much money to make something that works well.

"I'm feeling very lucky about now."

## AN UNSCIENTIFIC SUCCESS

**Mark Hogan, N5OBC**, of Broken Arrow, OK, writes that a recent weekend "brought another attempt at getting a signal out on 160 meters from my city lot.

"I read most of the antenna articles in the new SPRAT CD and thought I'd just hang a bunch of wire.

"(The result) is a cross between a bobtail curtain and a 'garden antenna.'

"At initial loading I had 300 ohms to the tuner and ended up with RF in the shack.

"That's when I ran the RG 8 out and up on the roof and whacked the 300 ohm where the RG 8 met up (scientific huh?).

"I did not have a balun, so I skipped that part and soldered direct to the RG8.

"The rig loaded on all but 20 meters. On that band I still have RF in the shack, (my personal computer speakers buzz even with three watts.)

"All other bands loaded to 1:1:1

"Yes even 160. The next test was to see how well did it hear.

"The guys on 40 that were S9 recently with the offset dipole were now +20 to +40.

"I had asked them for signal reports on the weekend before. They said I was readable but poor.

"This time they asked if I was running an amplifier.

"I was from +10 to +20 over to the north-northeast and south.

"Everyone I spoke with said I had a very good signal for 100 watts, (I know this is a QRP periodical, but you've got to remember, I was testing . . .)

"As the evening progressed I got brave, loaded 160 meters and spoke to Dallas and Beaumont, TX.

"I had been on 80 meters the week before and was low but readable, so loading it on 3.916 MHz, I asked if I could be heard and again they were



surprised that I was not running any more than 100 watts.

"The signal reports were again from S9 to +20 over around Texas, Indiana, Tennessee, Arkansas, Oklahoma, and Arizona.

"What did I learn from this?

"It sounds better than the last attempts. I can hear a lot more people and quite a few of them can hear me, (which is what I was after!).

"I suppose the best thing I learned is - as someone said the other day - any antenna is better than no antenna.

"I am by no means a contest station, nor, as you can surmise, not very scientific (it takes too much effort).

"All I really wanted was to emit a signal and be heard!

"I hope this boosts my CW QRP efforts on 40 and now I think I can try 80 for some nets as well.

"I was very careful cutting the top section, cut a piece of 70' wire in half and let it hang from the ends as I raised the antenna.

"The ends were pulled to within 8' or so of ground; cut twisted through some insulators and tied off to my privacy fence.

"They run down about 90 degrees but off to the side in order to be a little longer.

"I've had a RG 8x / balun fed 66' dipole, a 300 ohm fed 66' dipole, an offset 66' dipole fed with 300 ohm wire - all at the same height as this and one 66' sloper, but this is the loudest I've heard or been heard so far."

### 300 MW GOES A L-O-N-G WAY

Brad Hutton, W1XV, writes from Bow, NH, that "for all those who posted QRP-L listings on the recent ARRL DX Contest, congratulations for a job well done!

"Of course, every exchange is 599 both ways . . . is it ever different than that?

"You *have* to smile, though, when you're running a fraction of a watt and the other guy sends "599 KW" . . . then he

acknowledges your 300 milliwatt signal.

"Just goes to show you, doesn't it?"

"I dabbled at the contest off and on and never spent more than 30 consecutive minutes in the radio shack because of other things to do.

"However, I did manage about three hours of operation during which time I made 53 contacts in 43 countries (including all 6 continents) with less than a watt.

"I used an Omni VI for 10 and 15 meters and an OHR 100A for 20 meters.

"The Omni will only go as low as 1,100 milliwatts on 20 meters.

"I did work Australia on 10 meters with 5 watts, but I needed a VK for DXCC QRP CW and didn't want to miss it.

"I tried in vain to work him with less than a watt but it was fruitless.

"I only answer CQs, but I do believe that I worked everyone to whom I responded.

"I upped my total of DXCC milliwatt countries by 5 to a new total of 85.

"The closer you get to 100, the tougher it is to find a new one!

"New ones worked were: ZD8, 6V6, TG, ER and KP2.

"I have only 37 countries confirmed but I am not going to support the postal system this time around - through the bureau or a stateside manager only is my new moto.

"The crux of this note is to get others interested in milliwattling.

"As you can see, it is fairly easy to snag 50 or so countries during a contest weekend.

"They want you in the log and will dig you out of the ether for a point!

"I have found that the second day of a contest is much more rewarding so usually concentrate on Sunday operating times.

"I didn't mention that I have an OHR WM-2 wattmeter that stays in line all the time with all the rigs. Nifty piece of equipment, to say the least!"

## 10 METER DX VIA QRP HT

Brian Milesbosky, N5ZGT, writes from Albuquerque, NM, that "it begins with me buying an AEA DX-Handy 10 meter QRP HT about 3 years ago for \$125 when the solar cycle wasn't all that good.

"The HT is in perfect condition with two crystals, one for the CW subband and one for the SSB subband.

"Not even a scratch on the housing!"

"Three years later, I pull it down from the closet shelf to give it a whirl since I'm on break from school and have lots of radio time all of a sudden.

"Standing in my backyard, putting out 1.5 to 2 watts with the AEA AN-28 10 meter whip (its gain is -2 dB according to specifications), I manage to get a hold of WH6WI in Hawaii on 28.325 USB.

"At first he had a rough time copying but after turning on his 706's pre-amp, he could copy me fine.

"He gave me a 5-1 though, but there was a lot of QSB on the band and many adjacent Central and South American stations. Not bad!

"I'm getting a card for this first QSO with this HT.

"I tried it on CW, but I heard nothing but beacons. I'd like to build a beacon myself one of these days.

"Anyway, I hope that everyone has been enjoying the bands."

## ... AND MORE CONTEST FUN

Jim Larsen, AL7FS, writes from Anchorage: "Greetings from Alaska.

"It was a real treat to work LY2FE and UA1DW in (a recent) contest.

"Conditions were very bad for Alaska but not as bad as two years ago.

"I had to wait for the signals to fade up so I could work a few, then it would fade out and there would be no signals on any QRP segment of any band.

"In 15 minutes to an hour it would be back.

"My log times show the ups and downs.

"Later the cycle seemed to shorten to 5 to 10 minutes. The whole contest was fun and I appreciate all who listened for me.

"I worked 23 states and six countries (Alaska, Hawaii, USA, Canada, LY2, UA1).

"I had two contacts on 10 meters, 16 on 15 meters, 27 on 20 meters and five on 40 meters.

"Amazingly, the states ranged all over the U.S.:

"Alaska, Alabama, Arizona, California, Colorado, Connecticut, Florida, Hawaii, Iowa, Idaho, Illinois, Massachusetts, Maryland, Maine, North Carolina, North Dakota, Nevada, New York, Ohio, Oklahoma, Oregon, Texas and Washington.

"With conditions as bad as they were, I was very surprised.

"Many of you may have worked NL7Z, Kevin from Wasilla, Alaska.

"He normally runs a kilowatt but he tried QRP at about 3 watts this contest weekend and I think he was pleased.

"He said it was nice not to have the loud fan from the amplifier running in the background.

"During the contest I had a total of 200 QSO points multiplied by 35 SPCs multiplied by 7 (1-5 watts) for a grand total of 49,000 points.

"I was running a Kenwood TS-450S running 5 watts.

"My antenna was a KLM KT34A at 40 feet + 2 elements on 40 at 38 feet."

-- 72, Richard Fisher, ki6sn

# QRP HINTS & KINKS

A NorCal Exclusive

Illustrated by Paul Harden, NA5N

#11

## Surface Mount Construction & the SMK-1

Keeping track of those teenie-weenie parts (TWP's)

### The SMC "Play Box"

From Walt Amos, K8CV

Use a Storage Box Lid for holding and containing parts while building

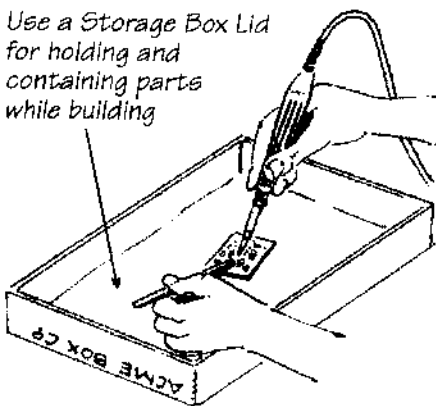

### Good Soldering Tips

From Rod Cerkoney, NØRC  
Ft. Collins, CO

Set soldering iron to 650°F

Radio Shack  
0.015" solder

Kester "Flux-Pen" #551 for  
wiping pad before soldering  
(Mouser #533-0951)

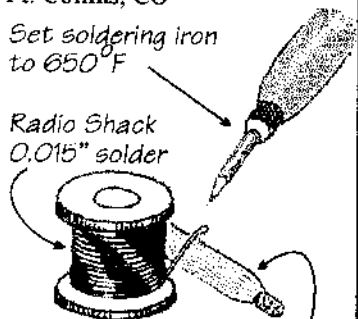

### SMC Sucker-upper

From Bob Parks, K6AEC  
Las Vegas, NV



Vacuum  
cleaner hose

Nylon  
Stocking

Rubber band

Missing 10K SMC Resistor

Nylon stocking acts as a filter for finding lost SMC parts dropped on the floor; shaggy rugs, etc. with vacuum cleaner. (Bob ... did your XYL notice the missing nylons yet?)

## Hold-down (3rd Hand) Fixtures for Soldering SMC Parts "Goofy-looking goose-shaped holder-downer doofuses"

As originally described (and named!) by Mahlon Haunschild, N4EEE

From Jim Giammanco, N5IB  
 (see [www.qsl.net/~n5ib](http://www.qsl.net/~n5ib))

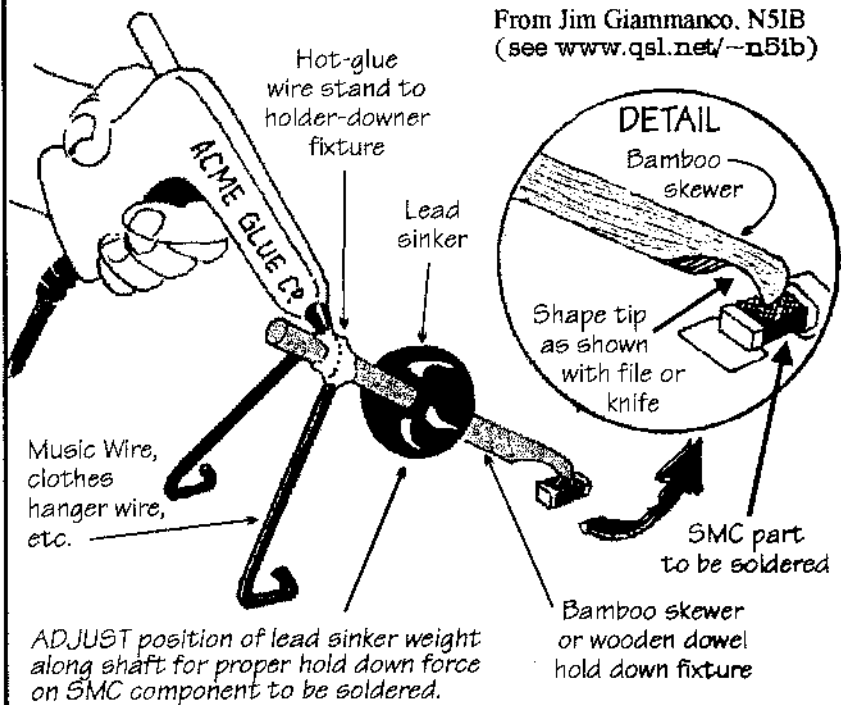

## The "Florida Keys" Hold-down Jig

From Jerry Henshaw, KR5L  
 Miramar, FL  
 (see [www.qsl.net/~n5ib](http://www.qsl.net/~n5ib))

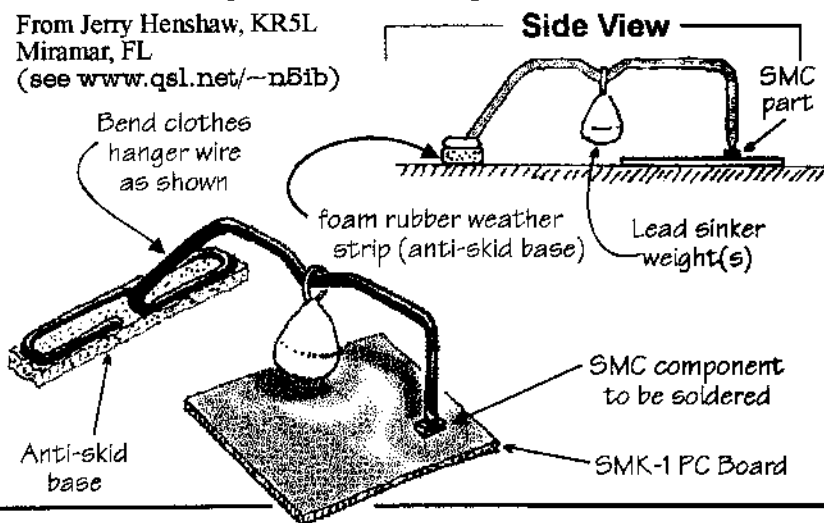

### Clothespin Hold-down

From James Rue, KC5HAC

SMK-1  
Board

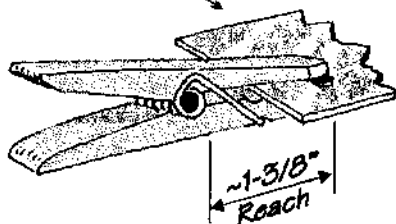

James uses a simple clothes pin, modified as shown below, for holding down the SMC parts.



Cut-down or  
file-off the  
ridges from  
top piece



Taper as shown  
(TOP view)



### SMC Tinning Aid

From Bob Hightower, NK7M  
Chandler, AZ

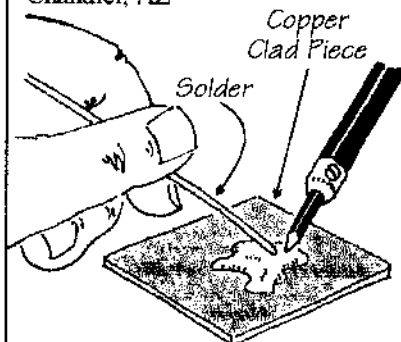

Form small pool of solder on a  
scrap piece of copper clad board

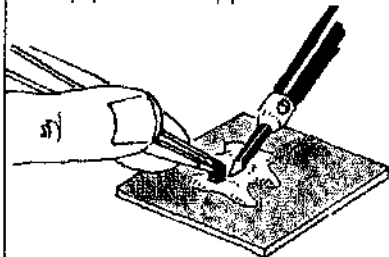

Re-heat pool of solder to "tin"  
SMC component.

### A "3rd Hand" for Soldering

From Ron Smith, KE6RS  
Somewhere in CA

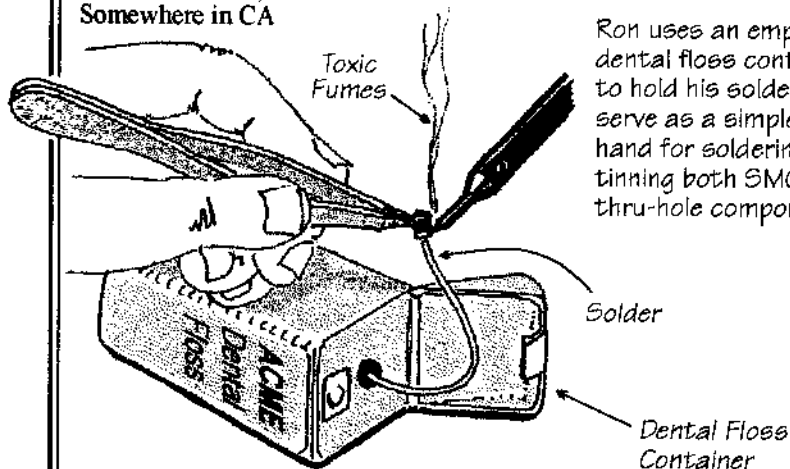

Ron uses an empty  
dental floss container  
to hold his solder AND  
serve as a simple third  
hand for soldering and  
tinning both SMC and  
thru-hole components.

## The "Yet Another SMT Hold-down Jig"

From Bill Jones, KD7S

For details see

[www.psnw.com/~kd7s](http://www.psnw.com/~kd7s)

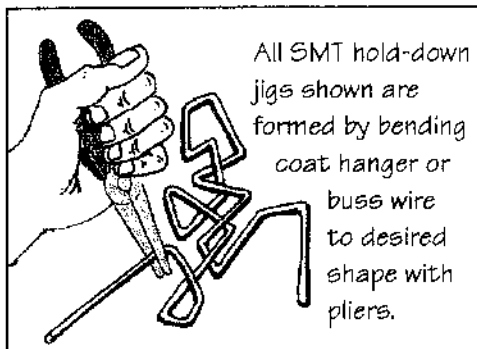
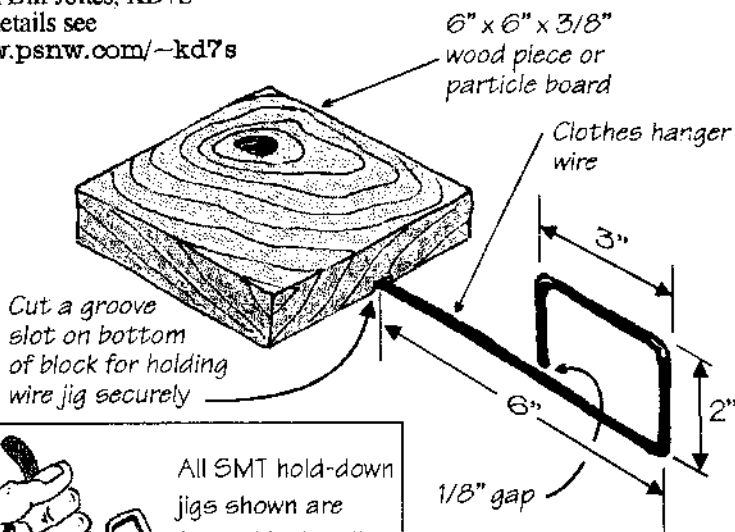

Build SMT hold-down jig as shown. Adjust the 6-inch length for proper "springiness" desired to hold SMT component in place for soldering.

## Easy 1-Watt Mod for the SMK-1

Designed by: Wayne McFee, NB6M

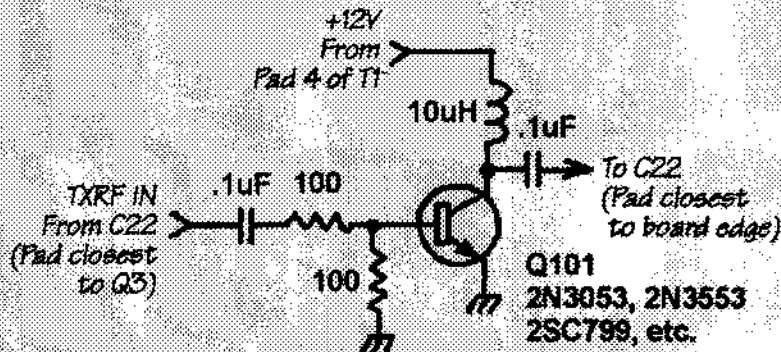

For more details, see the NorCal website:

[www.fix.net.com/norcal/smk1](http://www.fix.net.com/norcal/smk1)

# 1999 QRPp Back Issues

**Now Available**

**\$20, plus \$4 S&H US, \$6 DX**

**To Order: Send Check or Money order made out to  
Doug Hendricks, NOT NorCal to:**

**Doug Hendricks  
862 Frank Ave.  
Dos Palos, CA 93620**

**Please enclose a self addressed mailing label.**

## **QRPp Subscriptions**

QRPp is printed 4 times per year with Spring, Summer, Fall and Winter issues. The cost of subscriptions is as follows: US and Canadian addresses: \$15 per year, issues sent first class mail. All DX subscriptions are \$20 per year, issues sent via air mail. To subscribe send your check or money order made out to Jim Cates, NOT NorCal to: Jim Cates, 3241 Eastwood Rd., Sacramento, CA 95821. US Funds only. Subscriptions will start with the first available issue and will not be taken for more than 2 years. Membership in NorCal is free. The subscription fee is only for the journal, QRPp. Note that all articles in QRPp are copyrighted and may not be reprinted in any form without permission of the author. Permission is granted for non-profit club publications of a non-commercial nature to reprint articles as long as the author and QRPp are given proper credit. The articles have not been tested and no guarantee of success is implied. If you build circuits from QRPp, you should use safe practices and know that you assume all risks.

QRPp, Journal of the NorCal QRP Club  
862 Frank Ave.  
Dos Palos, CA 93620

**P R E S O R T**  
**FIRST-CLASS**  
Permit #72  
Socorro, NM  
87801



Volume VIII No. 2

SUMMER 2000

# QRPp

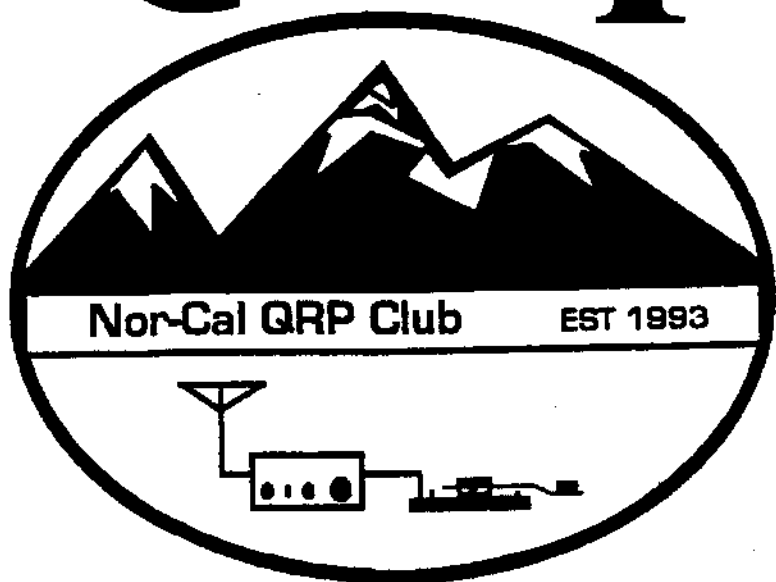

## Summer 2000

Journal of the Northern California QRP Club

## Table of Contents

From The Editor .....	2
Doug Hendricks, KI6DS	
The "L" Network, Revisiting an Old Favorite Tuner .....	4
John Kirby, N3AAZ	
"Two for the Road"	
A Two Band Transceiver for 40 and 20 Meters .....	7
Wayne McFee, NB6M	
Operating QRP: It's A Contact Sport .....	25
Mike Gipe, K1MG	
Learning Electronic Circuits:	
from the Desert Rat Regen Receiver .....	44
Paul Harden, NA5N	
The "BLT", a Balance Line Tuner .....	52
Charlie Lofgren, W6JJZ and Doug Hendricks, KI6DS	
Pacificon 2000 QRP Forum Announcement .....	60
QRP Operating New .....	63
Richard Fisher, KI6SN	

### From The Editor

by Doug Hendricks, KI6DS

There is a lot going on in QRP these days, and one of the first things that you probably want to know about is what is going on with QRPP? As you know, I had triple bypass surgery last year, and we got way behind with QRPP. The winter issue did not come out until May, and the spring issue is still not out. The copy was sent to the printer in early May, but he has had several things get in the way of his being able to complete the issue. It will be mailed.

I was gone on an extended vacation with my wife as I visited the east coast again this year, and did not have my finger on top of things. When I returned in August, I fully expected QRPP to have been sent, and it wasn't. I started on the summer issue and have

had it finished for several weeks, but have been waiting for the spring issue to be mailed.

I did not want to mail the summer issue until the spring one came out, as it does not give guys time to renew. The decision has been made to go ahead and mail the summer issue, and to give anyone who had their subscription expire the summer issue, hoping that they will go ahead and subscribe.

We have been in this situation before, and it is obvious to me now that we must print QRPP locally, so that I can keep tabs on things. It is not fair to the subscribers to have this happen. The plan is to mail this issue as soon as it gets back from the local printer, and to do the fall issue

immediately, with it shipping by Pacificon if at all possible. I thank each one of you for your patience. I will take full responsibility for the lateness of QRPP and will see that it gets out on time in the future.

We have a new membership manager. Paul Maciel, AK1P, has been doing the data base management for us for some time, and is doing a fabulous job. All questions about your subscription should be addressed to Paul. Here is his contact information:

Snail Mail:  
Paul Maciel  
1749 Hudson Dr.  
San Jose, CA 95124

Email:  
pmaciel@inow.com

Many of you are also anxious to hear about the progress of the full featured 10 meter surface mount kit. Mike Gipe, K1MG, is the designer, and he has been buried at work. When I returned from vacation, Mike contacted me and told me that he would not be able to even think about working on the project until late fall. The project is still in the works, but it has been delayed.

Sometimes you get lucky. Dan Tayloe, N7VE, has designed a wonderful new transceiver that uses the patented Tayloe mixer, and will be on 40 meters. It does not use ANY 602's at all!!! This is exciting news, as they are very hard to come by at this time. Dan's

rig is going to be a portable operators delight. It will be a hybrid kit, using both surface mount and through hole components.

The rig is called the Mini-Stinger. We will package it as a complete kit, with a case, all controls, and even a built in Antenna Tuner!! The rig will have RIT, Keyer, built in Antenna Tuner, SWR indicator, Audio Frequency Annunciator, self contained battery holders for 6 double A batteries, and will run from 5 to 18 Volts!! The best thing about this rig is the current drain. Dan's prototype draws about 7 mils of current. This could be the all time low current champion. The transmitter will put out about 3 watts and be continuously variable from 0 to 3 W. We plan on doing a painted, silkscreened case, so all you will have to do when you finish building the kit is to grab your paddles, a piece of wire for an antenna, and get on the air!!

The goal is to sell this kit for less than \$100 complete, and it doesn't look like there will be a problem. Dan will be one of the featured speakers at Pacificon, and I hope to see you there as he introduces the next NorCal kit.

Speaking of Pacificon, check out the exciting events that we have planned for you on pages 60 and 61 of this issue.

Thanks again for being patient with us. We are going to do a better job of getting QRPP out to you in a timely fashion. 72, Doug, KI6DS

## The "L" Network, Revisiting an Old Favorite Tuner

by John Kirby, N3AAZ

204 Holly St.

Centreville, MD 21617

What do these terms have in common? QRP, backpacking, efficiency, zero-weight feedline, low pass filter, stealth, home brew, omni-directional, all band, an outstanding tuner?

Answer . . . One inductor and one capacitor, the "L" Network

Figure 1 shows a no feedline, portable, long wire antenna system I used a few years ago in a pop-up camper. This setup will

clips and a tuning indicator. The earth ground "system" is just a common screwdriver and "vice-grip" (wire clamp).

Coax feedline was not required (in Figure 1) because the "L" network is connected direct between transceiver and base (or feed point) of the antenna. The feedpoint of the long wire antenna is located inside the shack (camper, tent or sleeping bag).

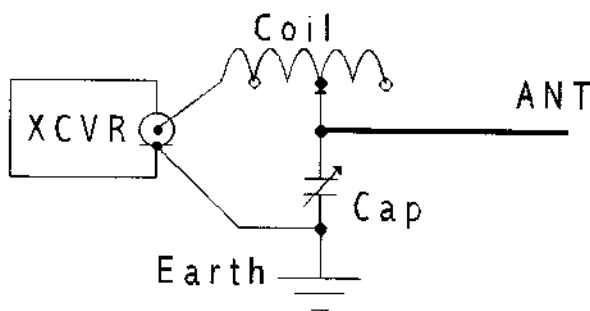

Fig. 1 "Long" ANT-No Feedline

match most 100 foot long wire antenna configurations from 80 through 10 meters. The coil is 21 turns of solid 18 AWG wound on a "stack" of three, Micrometals, RED (MIX 2), T94-2, powdered iron cores, with a "tap" placed every three turns (Figure 3). The capacitor is a 200 pico Farad variable. The antenna wire is a small roll of inexpensive, insulated, stranded, zip cord. You will need "alligator"

Since the tuning indicator can take many forms it is noteworthy to say, that if it takes too long to adjust ANY antenna tuner, the "fi-



21 Total Turns, Tap Every Third Turn

Fig. 3 Coil Detail

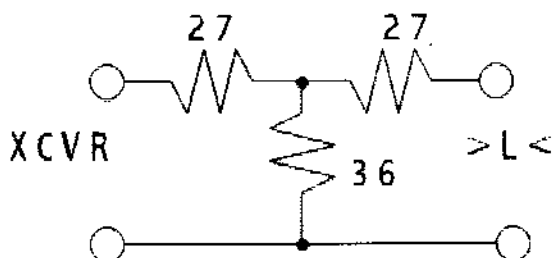

Use high Watt carbon resistors

Fig. 4 50 Ohm, 10dB Attenuator

nal RF amplifier" in your transmitter may be at risk to over heating. I suggest, install a 10 dB attenuator (figure 4) between the transmitter and tuner to help protect the PA transistor during the "initial" adjustment. The "attenuator" technique is NOT a guarantee. The safest method is reduced transmitter power and short (intermittent) "key down" adjustments. The attenuator is removed for "final" adjustment and QSOs.

#### The "L" Network

For the purpose of this discussion the term long wire antenna refers to a non resonant wire element that is either, straight line,

zigzag, horizontal, vertical, or combination, but always longer than a half wave at the operating frequency, a counterpoise is not required but a good earth ground helps.

The approximate half wave length in feet can be determined by dividing 468 by the operating frequency in MHz. Example, Length(ft) = 468 / F(MHz), a half wave at 7.04 MHz is approximately 66.5 feet.

How does the "L" network match a low impedance transmitter to high impedance long wire? Connect the coil in series between the XCVR / ANT junction and con-

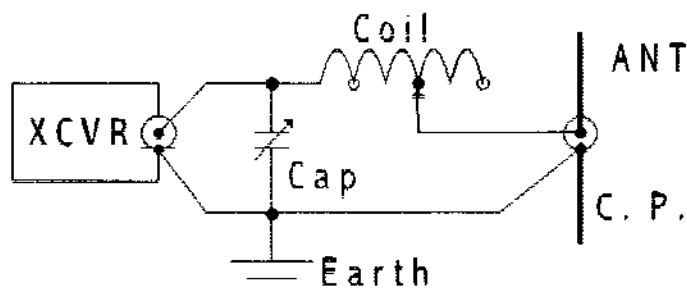

Fig. 2 "Short" ANT

nect the capacitor from the COIL / ANT junction to the XCVR chassis and earth ground, see figure 1.

### The Short Version

The "L" network will also match most random, non resonant, "short", low impedance antennas. The short antenna refers to a wire or rod (whip), straight line, zigzag, vertical, horizontal or combination but always less than a quarter wave at the operating frequency. Any short antenna may be a compromise, and efficiency can be poor. Always use a counterpoise for best results. When matching a highZ (50 Ohm, transmitter) to lowZ (15 Ohm, short vertical) the inductor is connected in series between source and load. The capacitor is "shunt" or parallel to the source, see Figure 2. Note, this configuration is unlike (different) the "long" example above.

Today our camper is a fifth-wheel with an eight-foot aluminum ladder rack. I just add a Radio Shack # 21-937B Rack Mount Bracket and 108 inch whip to create a very nice support AND ladder rack counterpoise, antenna system. The base of my antenna is now atop that ladder rack so a feedline is required. Feedline may assert a "length" problem and affect the impedance the transmitter looks into when there is a reactive component on the other end. Why? In this case, the load (on the end of the feedline) is a non-resonant length of wire, i.e.

reactive component. Therefore, the transmitter in Figure 2 only sees 50 Ohms with a half wave, 50 Ohm feedline connected. Why? A half wave feedline "repeats" at it's INPUT what it "sees" at it's OUTPUT and the "L" network for the "short" antenna was designed to match a 50 Ohm source to a short 15 Ohm (approximate) short vertical antenna with an undefined counterpoise. Solution, adjust (re-tune) the "L" Network for each band and / or change the length of the feedline a foot or two.

### Conclusions

Exclude the feedline and it is noteworthy to say, the networks shown in Figures 1 and 2 match the Smith Chart yin / yang curves, i.e., there is most likely no point on the chart one or the other network will not match to 50 Ohm. Include a feedline of random length and the "L" network may not tune all the bands, however, the operative word is "random" length feed line.

### Some Theory and a Little Math

The impedance presented by the end of a random wire can range over a very large playing field, from only a few Ohms to several thousand Ohms. This calculation shows just one example, a 50 Ohm source to a 377 Ohm load.

First find K

$$K = \text{Sq.Rt.}((\text{HighZ} / \text{LowZ}) - 1)$$

$$K = ((377 / 50) - 1)^{0.5}$$

$$K = 2.56$$

Next find X(L), reactance of the matching coil.

$$X(L) = K \text{ times } LowZ$$

$$X(L) = 2.56 \times 50$$

$$X(L) = 128 \text{ Ohm}$$

Next find the matching coil value

$$\text{If } X(L) = 2 \text{ Pi } F L$$

$$\text{then } L = X(L) / 2 \text{ Pi } F$$

$$L = 128 / (6.28 \times 7.04E6) \gg 7.040 \text{ MHz} \ll$$

$$L = 2.89E-6 \text{ or } (2.89 \text{ uH})$$

The series inductor should be approximately 3 micro Henry

Next find X(C), reactance of the matching capacitor.

$$X(C) = HighZ / K$$

$$X(C) = 377 / 50$$

$$X(C) = 7.5 \text{ Ohm}$$

Next find the matching capacitor value,

$$\text{if } X(C) = 1 / (2 \text{ Pi } F C)$$

$$\text{then } C = 1 / (2 \text{ Pi } F X(C))$$

$$C = 1 / (6.28 \times 7.04E6 \times 7.54)$$

$$C = 3E-9$$

(3E-9) is 3 nano Farad or 0.003 micro F or 3000 pico F

For a 1:1 SWR, make C a variable capacitor. For example, if your variable capacitor has a value from 100 pF to 1000 pF with 500 pF center, then calculate from the example above:

$$(3000) - (500) = 2500 \text{ pF}$$

and then parallel fixed capacitors that total approximately 2500 pF with the 1000 pF variable.

To Bill, KD7S and L.B., W4RNL for their guidance and knowledgeable assistance, my pleasure, THANK YOU.

NOTE: I choose that all the above remain in public domain for Amateur Radio use. 72, John Kirby, N3AAZ

Comments and suggestions are welcome

n3aaz-qrp@juno.com

## "Two for the Road"

### A Two Band Transceiver for 40 and 20 Meters

By Wayne McFee NB6M

2379 Saint George Drive

Concord, CA 94520

There are some wonderful monoband CW transceiver kits out these days, and the SW series kits from Dave Benson, NN1G, are certainly well known. I built an SW-40, and after experiencing how good a rig it is, I started thinking about other bands.

I had been thinking about building a multiband rig, and queried Dave Benson about what all would need to be changed in order to make a multi-band rig out of one of his boards. It turned out that it would be much simpler to use multiple transceiver boards

than it would be to build the circuits and switching necessary to make a multi-band rig out of one board. So, I decided to build a two-band rig using one more of NN1G's SW series boards to go along with the SW-40 I already had.

After thinking for a while about what sort of features I wanted to incorporate, and having read the extensive treatment on tweaking the 40 Meter version of the board that was featured in the ARRL's book *AQRP Power*, I decided that I wanted dual VFOs, a fine tune control, a built-in Tick Keyer, a built-in Audio Frequency Annunciator, and a Keyer paddle built right into the front panel of the rig. With Dual VFOs, Split operation could be accomplished by manually switching from one VFO tune control to the other, when needed.

As I already had a board for one of the most popular HF ham bands, it seemed only natural that the second board would be for the other most popular HF band, 20 Meters. So, I ordered an SW-20+ and a Freq-Mite frequency counter/audio annunciator from Small Wonder Labs, and a Tick Keyer Chip from Embedded Research.

Next, the switching circuitry was tackled. I wanted all controls and connectors to be switched between the two boards, so that no extra controls or connectors were needed and I didn't have to unplug and re-connect any of the electrical connections to the rig. I

wanted the Tick Keyer and the Frequency Annunciator to work automatically with whichever board was powered up.

Although electronic switching of some of the elements was considered, it was unnecessary. Two Triple Pole, Double Throw toggle switches connect the antenna, audio output, Gain control and the dual VFO pots to the selected board. A Double Pole Double Throw toggle switch selects the desired VFO tuning control. The fine-tuning control is a 5K pot wired in series between Vr and the appropriate center pole of the Dual VFO selector switch. DC Power is supplied to the selected board by a center off position toggle switch on the front panel.

The Tick Keyer is electronically connected to the key lines of both boards by adding a 1N914 diode in series between each key line and the Key Jack, and connecting the keying transistor powered by the Tick Chip right across the Key Jack, with the keying line from the Tick Chip run to the base of that transistor. So that the Freq Mite receives supply voltage no matter which board was powered up, the anodes of two 1N914 diodes were attached to the two on terminals of the center-off power switch, their cathodes were connected together, and the supply voltage for the Freq Mite was taken from that point.

The 5 Volts regulated for powering the Tick Keyer is taken from the regulator circuit in the Freq-



Mite, so it has power no matter which board is activated. The Freq-Mite samples the transmitted frequency of whichever board is powered up at point B in the circuit, the wiper of the RF Gain pot. Because of the Diode T/R switching scheme, there is more than sufficient RF there on transmit for the Freq-Mite to sample.

The Freq-Mite can be set up to announce just the last three digits of the sampled frequency, in the case of sampling a heterodyne VFO. The transmitted frequency is being sampled here, and, by appropriate positioning of small jumpers on the Freq-Mite printed Circuit board, the Freq-Mite is set up to announce all the digits of the sampled RF. In practice, one needs only to key the rig momentarily, activate the Freq-Mite by pressing a push button on the front panel, and unkey the rig. The Freq-Mite then announces in CW the sampled frequency, at a user selected CW speed. Generally I check the frequency in this manner after the end of a QSO so I can put the info in my log.

There is enough audio available from both the Freq-Mite (CW frequency announcement) and Tick Keyer (side tone and mode selection) so that the audio outputs from both those circuits are run through selected values of resistance directly to the earphone jack. A 330 Ohm resistor was placed in series with the audio output from the Freq Mite, and .1 uf Capacitor and a 1 KOhm resis-

tor were placed in Series with the audio from Pin 3 of the Tick Keyer Chip. Your mileage may vary.

With the switching arrangement taken care of, the enclosure could be designed. At first, some thought was given to including a battery pack and a tuner in the rig. However, it was decided that having the battery pack outside the main enclosure would provide a very positive way of ensuring that the rig was off and preclude any chance for leakage or other corrosive problems from the battery pack. Since resonant antennas such as dipoles would be used in portable situations as often as non-resonant types, the tuner would be a separate item as well.

With those decisions made, work began on positioning the four circuit boards, all controls and connectors, and the built in Keyer paddle so as to end up with a small, QRP size enclosure. The material used for all the panels of the enclosure except the front panel is single sided PC board. It is very easy to cut, drill and shape, provides a built-in ground plane, and ends up being a good looking enclosure as well. Double sided PC Board was used for the front panel, as various items would be soldered directly to both sides of that panel.

Although there were some misgivings about what sort of interference and interaction problems might be created, the two main transceiver boards were placed back to back, spaced less

than one quarter of an inch apart. They are mounted on three tabs made from double sided PC Board, which are soldered to the left wall and rear panel of the PC Board enclosure. Operational tests performed upon completion of the rig proved that those misgivings were unfounded. No problems of any kind have been detected. Each board seems to act just like it would in a box all by itself.

The Keyer Paddle, Tick Keyer, Freq-Mite, Main Power switch and the two Band Switches are positioned to the right of the two main boards, with the power switch on the front panel, the paddle sticking out through the front panel, the two Band Switches on the rear panel, and the Tick Keyer and Freq-Mite boards attached to the right side panel of the enclosure.

The finished package, made from single sided PC Board material except for the front panel, looks quite nice and has no sharp edges or protruding screws. The front panel is made from double sided PC board because of the fact that various items are soldered directly to it, both front and rear. Both the front and rear panels are recessed 1/4" back from the front and rear edges of the top, bottom, and sides of the enclosure, which gives a pleasing look and also helps protect protruding switches, knobs and connectors. Although the paddle protrudes out about 3/4 of an inch from the front of the rig, about 1/4" further than

the two largest knobs, I have had no problems with damage from carrying the rig in my backpack or in my suitcase.

With the front and rear panels recessed 1/4", I simply tack soldered the top and bottom panels on in two spots to the front panel and two spots to the side panels for each piece. Simple enough to get off when I really need to, and no screws needed.

Here are the specifications:

Enclosure size:

5 1/8" Wide, 4 1/2" Deep, and 2 1/8" High

Inside dimensions (front and rear panels inset 1/4"):  
5" W, 4" D, 2" H

Front Panel Controls:

VFO 1 and VFO 2 Tuning  
Fine Tuning  
VFO Switch  
Receiver RF Gain  
Power On (20 Meters), Off, On (40 Meters)  
Freq-Mite Activator Button  
Tick Mode Control Button  
Keyer Paddle (single or dual)

Rear Panel Controls:

Band Switches (two)(select either 20 Meters or 40 Meters)

Rear Panel Connections:

Antenna  
DC Power  
External Key (or External Keyer if desired)  
Earphone (Low Impedance)

Transmitter Power Out, both bands 2.0 Watts with 13.8 Volt Supply (approximate)  
 1.5 Watts with 12.0 Volt Supply (approximate)

Here are the parts needed for the enclosure:

**Front and Rear Panel Layout**

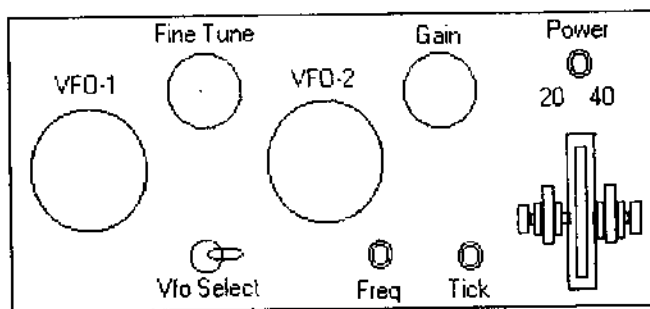

NB6M SW-20/40 Front Panel Layout

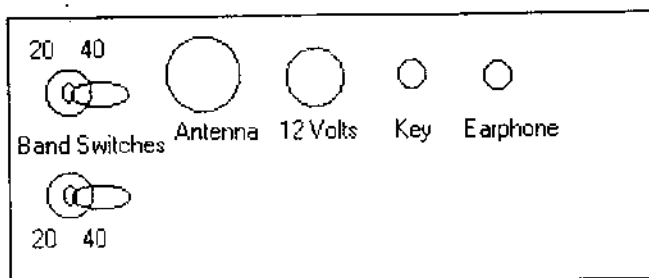

NB6M SW-20/40 Rear Panel Layout

All pieces are made from PC  
Board material. If available, make  
Two pieces needed, for sides

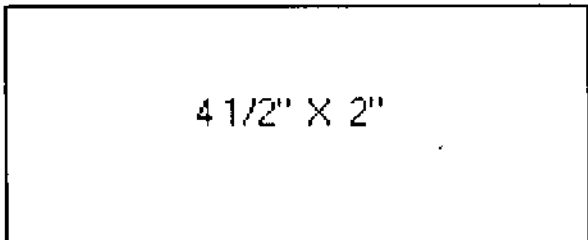

$4\frac{1}{2}'' \times 2''$

Two pieces needed, for front and back panels



$5'' \times 2''$

Two pieces needed, for top and bottom



$4\frac{1}{2}'' \times 5\frac{1}{8}''$

all but the front panel from single sided material, as that looks much nicer. The front panel must be made from doublesided material, as various items are soldered directly to both sides. (Grounds for pots, Paddle Adjustment screws, etc.)

### Parts List for the Rig:

1. Two mono-band transceiver boards (SW series from Small Wonder Labs, or your choice)
2. Freq Mite (Small Wonder Labs, or your choice of annunciator)
3. Tick Keyer Chip (Embedded Research)
4. Supply of PC board material (see enclosure parts drawing)

5. Triple Pole, Double Throw Switches - Two
6. Center Off, Two Position toggle switch - One
7. Double Pole, Double Throw toggle switch - One
8. Push Button switches - Two, Normally Open
9. 100 K Ohm Linear Taper Pots - Two
10. 5 K Ohm Linear Pot - Two (One if no Fine Tune control desired)
11. Antenna Jack
12. 12 Volt Power Jack
13. Key Jack
14. Earphone Jack

Schematic for the VFO controls and band-switching configuration:

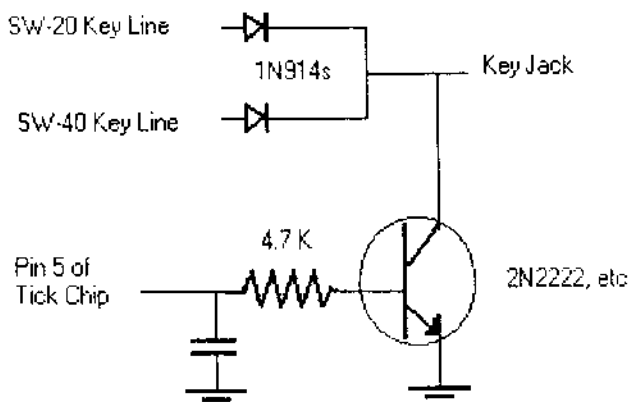

NB6M SW-20/40 Keying Circuit

AS LONG AS YOU DON'T TRANSMIT, it hurts nothing to power

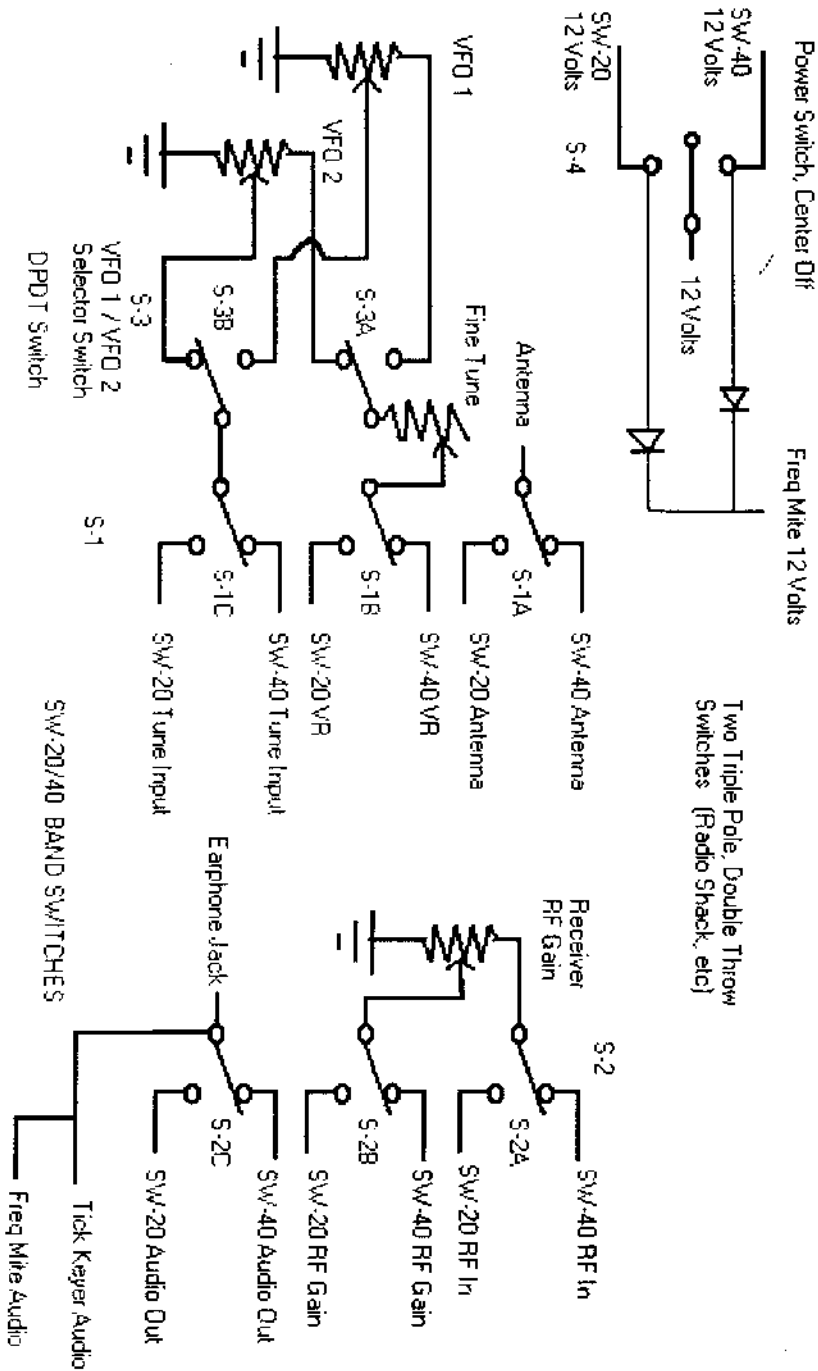

up one board when the band switches are set for the other. However, the best procedure is to select the desired band with the two band switches first, then power up the appropriate board with the main power.

When the rig comes on, you will hear the beeps from the Tick keyer indicating that it is on, and a CW "?" from the Freq Mite. If you press the Freq switch right after that, the Freq Mite will send its announcements in the faster of its two CW announcement speeds. If you don't press the Freq switch within two seconds, it sends the announcements in its slower speed. Depending on whether you have used the Tick keyer chip that has mode and speed memory built in, you will need to program it for your desired sending speed.

NOTE: The fine tuning pot should be a better quality one than those currently available from Radio Shack. A poor quality pot used in this configuration will start being erratic after a while, and you will notice erratic movement of the frequency when you adjust the fine tuning knob. If you choose not to modify the SW boards so as to provide the expanded frequency coverage as outlined by Dennis Monticelli, AE6C, and Mitchell Lee, KB6FPW, in their treatise on tweaking the SW series boards in QRP Power, you really don't need a fine tune control. With the normal 40-50 Khz of coverage of the SW series boards, the rate of tuning is fairly slow and it is easy to

fine tune a signal with the main tuning knob.

In practice, the dual VFO tune controls are wonderful for tail-ending QSOs by parking one AVFO" on that frequency, switching to the other and doing a band search for other QSOs as desired, and switching back to the first one from time to time so as to know when that QSO is ending and you can make your call.

The Keyer Paddle is built right into the front panel of the rig. The details of construction of the paddle are very similar to the methods outlined in a previous article by the author, entitled "The NB6M Paddles", published on the NorCal QRP Club Website, and in the March 2000 QST magazine from the ARRL. Instructions and drawings are included below so that either a single or dual paddle setup can be constructed. I suggest you read the original article first, before starting on this project. It can be read and downloaded from the NorCal QRP club website.

After my article about the NB6M paddles was posted on the NorCal Page, I collaborated with Carel Mulder, PA0CMU, in helping him make a dual paddle. Then Doug Hendricks, KI6DS, took my design a bit further yet with his idea of mounting the adjustment screws for the dual paddles right on the paddles themselves, and made a dual paddle for the Fort Smith, Arkansas, QRP Club kit, the P-Tick. Now I have included

his idea for mounting the adjustment screws on the paddles themselves in my design for a dual paddle setup built right into the rig.

The paddles are mounted on rectangular stand-offs, made from double sided PC Board, that are soldered to the inside of the right side of the PC Board enclosure for the rig. The adjustment screw

supports for the single paddle setup are soldered to the front of the front panel of the rig= PC Board enclosure, and in the dual paddle setup, the adjustment screws are attached directly to the paddles themselves.

In addition to the PC Board parts, you will need two 4-40 X 1/2" Brass screws, four 4-40 Brass

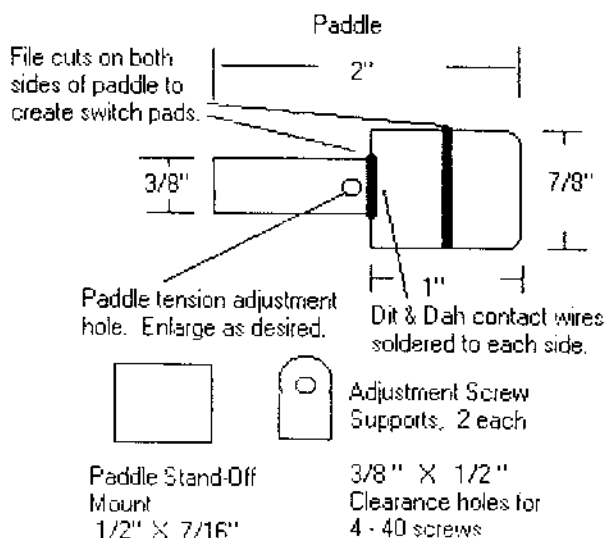

### Parts for the single paddle setup

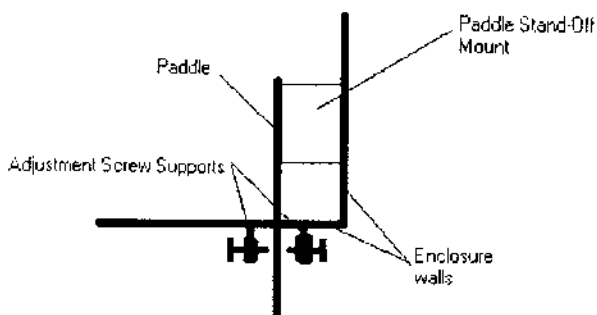

### Overhead View: Built in Paddle



nuts, and one 4-40 X 1" Brass screw to help with the installation of the Adjustment Screw Supports.

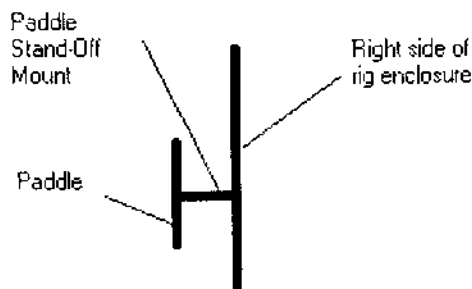

Frontal view of Paddle Stand-Off Mount Details

From the front, without the front panel, the single paddle installation looks like this.

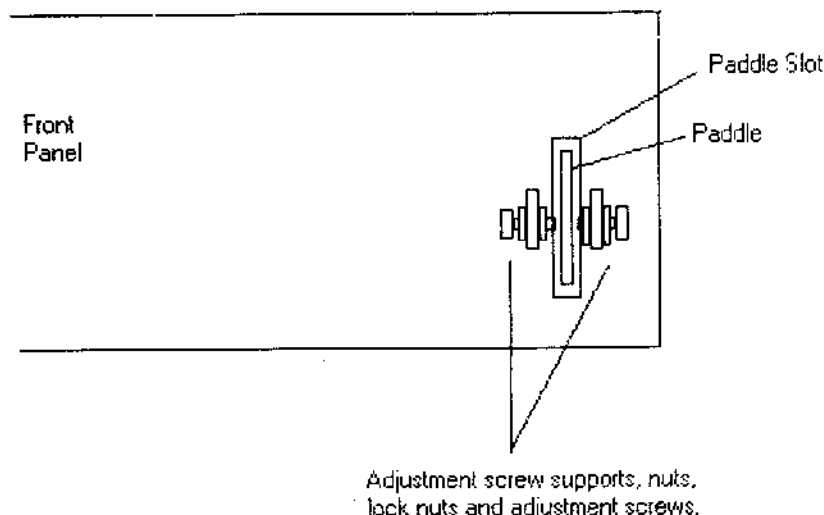

With the front panel installation shown, the single paddle setup looks like this.

## Dual paddle parts.

In addition to these PC Board parts, you will need two 4-40 X 1/2" Brass screws, and four 4-40 Brass nuts.

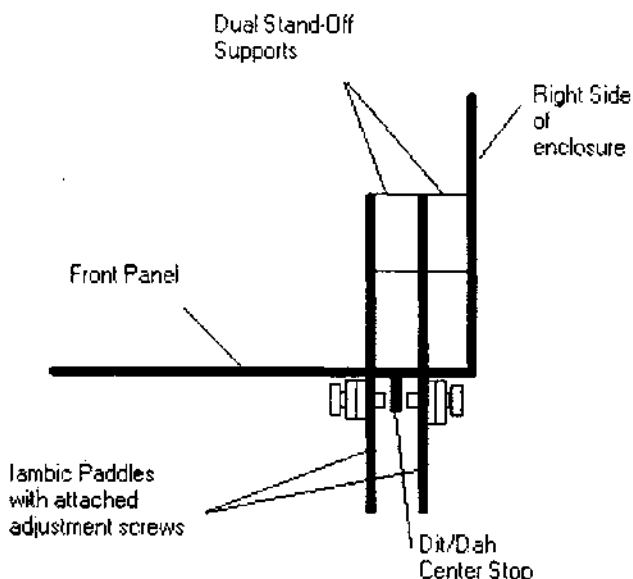
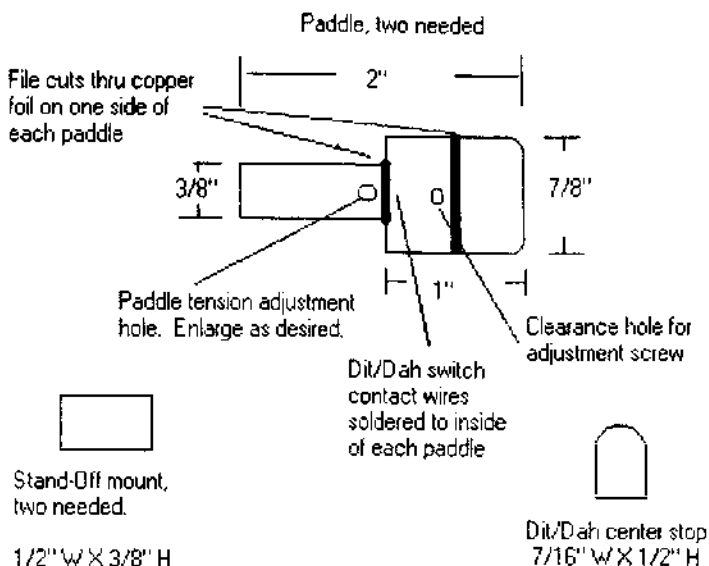

From overhead, the dual paddle installation looks like this.

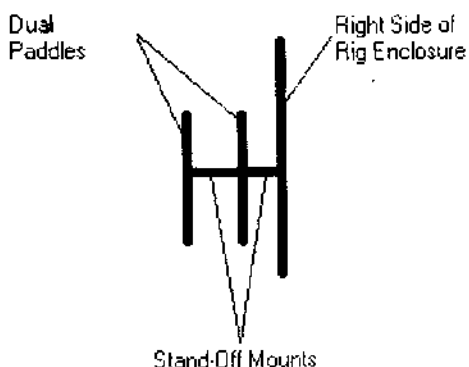

#### Dual Paddle Mounting Details

Front view of dual paddle installation without front panel.

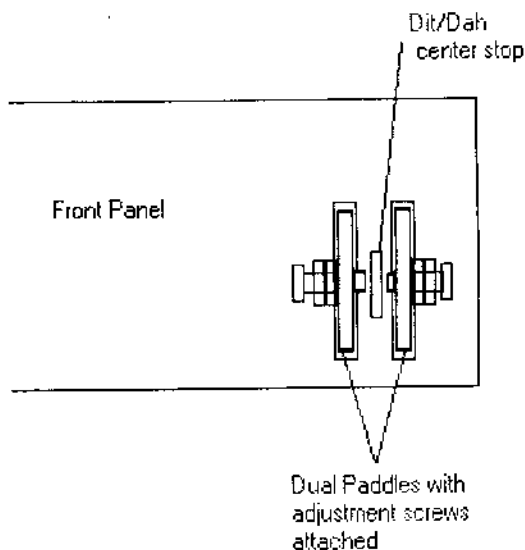

The dual paddle setup looks like this with the front panel installation complete.

All of the parts for the keyer paddle setup are made from double sided PC Board. First, draw the individual parts for the

paddle setup you desire on a piece of PC Board.

Leave the Paddle Stand-off Mount or mounts about a 1/16"

wider than the indicated width so that you can file them to final dimension during the installation process. This will help ensure that each paddle ends up pretty well centered in the slot cut for it in the front panel of the PC Board enclosure. For my single paddle setup, I cut a vertical slot 1/8" wide and 1" tall, centered 1/2" from the right edge, and placed vertically below center because I installed the main power toggle switch directly above it. The individual slot placement depends on the layout of your particular rig.

Drill all the holes in the pieces before sawing the parts from the board. I ended up with a hole about a quarter of an inch in diameter for the paddle tension adjustment, but I suggest you start with a smaller size and use a tapered reamer (Radio Shack) for enlarging it after the paddle is cut from the board and shaped. You could place about a half inch (length of the stand-off support) of the narrow end of each paddle into a small bench vise and try the tension, then enlarge the tension adjustment hole a little at a time until you have the desired amount of tension.

Using a Hack Saw, cut the pieces from the board. Round the corners and smooth the edges of the pieces with a file.

For the single paddle setup, the copper foil is cut in two places on each side of the paddle. This can be done with either the edge of a small file or with a hack saw.

Cut just enough to be sure you have separated the copper foil nicely. What you are doing is creating the switch contact pads for the Dit and Dah sides of the paddle. It is necessary to cut the foil in two places on each side of the paddle, as shown in the drawings, so that static electricity and other stray electrical currents from your skin won't cause erratic keying. For the double paddle setup, the cuts are made just on one side of each paddle.

For the single paddle setup, I soldered one 4-40 brass nut to one side of each of the adjustment screw supports, in order to provide the threads for the screws to fit into. You could simply drill and tap (with a 4-40 tap available at any hardware store) the PC board material and use just the lock nuts. However, in the interest of strength and durability, I recommend soldering a nut to each support. For the double paddle setup, one 4-40 brass nut is soldered to the outside of each paddle for the adjustment screws to fit into.

### **The single paddle assembly procedure is as follows:**

First, cut the slot, in the appropriate location for your layout, in the front panel. I did it by drilling a series of 1/8" holes in a vertical line, and then using a small, flat file to shape the slot by removing the material left between the holes.

Then, solder a brass nut to one side of each of the two ad-

justment screw supports. A small board with a hole in it lying on your work table is useful here. Screw a brass screw into a nut and place the end of the screw through the hole in the support and into the hole in the board. This will place the nut against the support with the screw centered in the clearance hole. Solder the nut to the support, let it cool, and remove the screw from the nut. Repeat with the other support.

Position the rig so that the front panel is facing up, and is horizontal. Then, position the two adjustment screw supports on the front panel, and solder them into place. The trick to positioning them is to screw a one inch long 4-40 brass screw through both supports, leaving about 3/8" between the two soldered-on nuts, which should be on the inside of each support, facing each other. Use the slot as a guide for placing the adjustment screw supports, as the supports should be on opposite sides of the slot, each one an equal distance from the slot, and centered vertically in relation to the slot. The two supports should be far enough from the slot so that a good, strong bead of solder can be run along the inner joint of the support and the front panel.

First, tack solder each side of the two supports. This will ensure that they don't move during the soldering process. Then run a good bead of solder along the lower edge of each support.

Once the pieces are tack soldered and you want to run a bead of solder between the two surfaces, which are at 90 degree angles, the trick is to prop the unit up so that the two surfaces form a V, with the apex at the bottom and the two sides about 45 degrees from the vertical. This way, the melted solder will run quite nicely along both sides of the joint, and form a very strong and nice looking connection.

Next, remove the one inch screw from the adjustment screw supports, install the two lock nuts, one on each adjustment screw, running the lock nuts right up to the screw heads, and screw the adjustment screws into their respective supports. Leave a space between the two screws that equals the width of the slot.

Then, lay the paddle flat on your work table and position the stand-off mount so that it's long side is centered in the narrow end of the paddle and the stand-off is vertical in relation to the paddle, as pictured below.

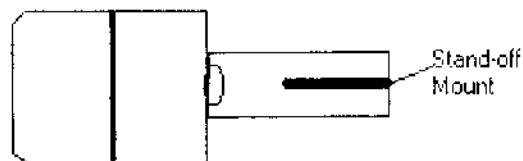

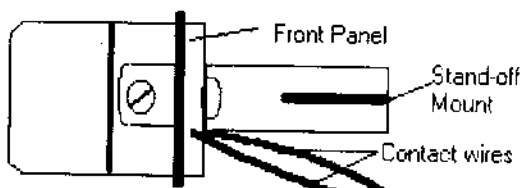

Tack solder one side of the stand-off mount to the paddle, check to see if it is still vertical, 90 degrees to the paddle, tack solder the other side, then run a good bead of solder along both sides.

Now slip the finger end of the paddle through the slot in the front panel, from the rear, with the stand-off mount towards the rear wall of the enclosure. Check to see how much material needs to be removed from the stand-off support in order to center the paddle in the slot. Remove the paddle and file material from the stand-off support. File a little at a time and try the paddle, then remove a little more. Pretty hard to put material back on once you have filed it off, so take your time.

Once you are satisfied with the amount of material removed from the stand-off support, solder the two wires for the Dit and Dah switch contacts from your keyer to the back edge of each switch contact on the paddle, as shown in the drawing below. If you are right handed, the Dit wire goes on the right side of the paddle and the Dah wire goes on the left.

Then slide the paddle in through the slot from the rear until the solder joints attaching the contact wires to the paddle are just

clear of the back of the front panel and the file cuts separating the switch pads from the touched portion of the paddle are just outside the adjustment screw supports, as shown in the drawing above.

Position the stand-off mount against the side of the enclosure and hold the paddle assembly in place. Screw the adjustment screws in until they are both against the paddle and the paddle itself is centered in the slot. Check to see that the paddle is parallel to the slot, and is parallel to the bottom of the enclosure. Tack solder one side of the stand-off mount to the enclosure, re-check the positioning and alignment of the paddle and tack solder the other side of the stand-off mount. Then, run a good bead of solder along both sides of the stand-off mount.

Now, loosen the two adjustment screws slightly and adjust them for whatever switch gap feels good to you. Tighten the lock nuts to maintain that gap. That's all there is to it for the single paddle setup.

#### **Double paddle installation:**

Cut the two slots in the front panel of the enclosure in the locations you desire. The actual spac-

ing of the paddles in terms of the distance from the near enclosure wall and the distance between paddles is up to you, depending on your layout and the paddle spacing you desire.

Then, draw the parts on the PC Board. Drill the holes before sawing out the parts, just as we did for the single paddle setup. Make the tension adjustment holes in the two paddles smaller to begin with, about 1/8", and enlarge them as desired after the parts are cut out. For the double paddle setup, you need adjustment screw clearance holes and tension adjustment holes in each paddle.

Make the two Stand-off Mounts wider than specified initially, so they can be filed to finished dimensions to match the spacing of your two slots in the front panel. The stand-off mount which goes between the wall of the enclosure and the nearest paddle is made initially just wider than the distance from the wall to the center of the closest slot. The stand off mount that goes between the two paddles is made initially just wider than the distance between the centers of the two slots.

Although a dimension is specified in the drawing for double paddle parts, the actual distance between paddles and the distance between the paddles and the enclosure wall is up to you and the stand-off mounts are made accordingly.

Saw out the parts with the

hack saw, smooth the edges with the file, and make the two switch pad cuts on one side only of each paddle. This will now be the outside of each paddle. Drill the tension adjustment holes and the screw clearance holes. After drilling the clearance hole for the adjustment screw, use a countersink bit to remove a little copper foil from around the hole on the side opposite the switch pad (inside surface). Otherwise the switch pad will be grounded all the time by the screw. Make your adjustments to the size of the tension adjustment holes in the two paddles. Try to get the tension as close to equal in the two paddles as possible.

Position the rig so that the front panel of the enclosure is up, and is horizontal with your work table surface. Position the Dit/Dah Center Stop between the two slots, parallel to the slots and centered between them, perpendicular to the surface of the front panel. See the drawings of the double paddle setup for further clarification if needed.

Tack solder one side of the Center Stop, check its position, and tack solder the other side. Then, run a good bead of solder along both sides of the Center Stop, making a good, strong joint with the front panel.

Now, lay one paddle flat on your work table, with the switch pad file cuts UP, and position one Stand-off Mount centered in the narrow end of the paddle, perpen-

dicular to its surface, as pictured below.

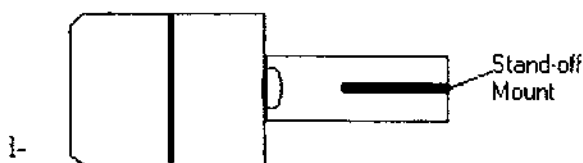

Tack solder one side of the stand-off mount to the paddle, check its position, and tack solder the other side to the paddle. Then run a good bead of solder along both sides of the joint.

Now slip the finger end of the paddle through the slot in the front panel closest to the side wall of the enclosure, from the rear, with the stand-off mount towards the rear wall of the enclosure. Check to see how much material needs to be removed from the stand-off support in order to center the paddle in the slot. Remove the paddle and file material from the stand-off support. File a little at a time and try the paddle, then remove a little more. Pretty hard to put material back on once you have filed it off, so take your time.

Once you are satisfied with the spacing of the paddle in the slot, solder either the Dit or Dah contact wire from your keyer to the back edge of the switch pad, just in front of the tension adjustment hole in the paddle. The selection of Dit or Dah wire will depend on which hand you normally use the paddle with. If you are right handed, this will be the Dah contact.

Then slide the paddle in through the slot from the rear until the solder joint attaching the contact wire to the paddle is just clear of the back of the front panel, and the file cut separating the switch pad from the touched portion of the paddle are just even with the outermost edge of the Dit/Dah Center Stop. There needs to be enough space between the clearance hole for the adjustment screw and the front panel so that when you solder a 4-40 nut in that location it will clear the front panel.

Position the stand-off mount against the side of the enclosure and hold the paddle assembly in place. Check to see that the paddle is centered in the slot, that the paddle is parallel to the slot, and is parallel to the bottom of the enclosure. Tack solder one side of the stand-off mount to the enclosure, re-check the positioning and alignment of the paddle, and tack solder the other side of the stand-off mount. Then, run a good bead of solder along both sides of the stand-off mount.

Now, lay the other paddle flat on your work surface, with the switch pad file cuts DOWN and



position the other Stand-off mount as you did with the first paddle, and as pictured below.

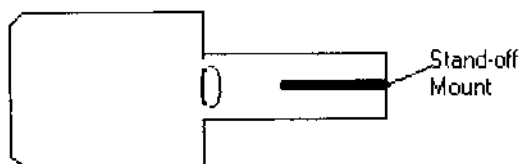

Tack solder one side of the stand-off mount to the paddle, check its position, and tack solder the other side to the paddle. Then run a good bead of solder along both sides of the joint.

Slip the finger end of the second paddle through its slot in the front panel, from the rear, with the stand-off mount towards the first paddle. Hold the second paddle's stand-off mount against the first paddle and check to see how much material needs to be removed from the stand-off support in order to center the second paddle in the slot. Remove the paddle and file material from the stand-off support. File a little at a time and try the paddle, then remove a little more. Pretty hard to put material back on once you have filed it off, so take your time.

Once you are satisfied with the spacing of the paddle in the slot, solder the other contact wire from your keyer to the back edge of the switch pad, just in front of the tension adjustment hole in the paddle. If you are right handed, this will be the Dit contact.

Then slide the paddle in through the slot from the rear un-

til the solder joint attaching the contact wire to the paddle is just clear of the back of the front panel, and the file cut separating the switch pad from the touched portion of the paddle are just even with the outermost edge of the Dit/Dah Center Stop. As with the first paddle, there should be enough distance between the clearance hole for the adjustment screw and the front panel so that when you solder a 4-40 nut in that location it will clear the front panel. Also, the outer end of the second paddle should be even with the outer edge of the first paddle.

Position the stand-off mount against the first paddle and hold the paddle assembly in place. Check to see that the paddle is centered in the slot, that the paddle is parallel to the slot, and is parallel to the bottom of the enclosure. Tack solder one side of the stand-off mount to the first paddle, re-check the positioning and alignment of the paddle, and tack solder the other side of the stand-off mount. Then, run a good bead of solder along both sides of the stand-off mount to form a good, strong joint between it and

the first paddle.

Now screw two brass nuts onto an adjustment screw, running one of the two right up against the head of the screw and positioning the other nut about 3/16" from the end of the screw. Install two nuts on the other adjustment screw in the same fashion.

Turn the rig onto one side, so that one of the paddles is horizontal, parallel to your work surface. Place one adjustment screw assembly into the clearance hole in the upper paddle as pictured below, and solder the lower nut to the paddle.



Turn the rig over so that the other paddle is up and horizontal, parallel with your work surface. Place the other adjustment screw assembly in position, and solder its lower nut into place on the paddle. Once both adjustment screw assemblies have cooled, adjust the spacing for the Dit and

Dah contacts with the adjustment screws, and, when you are happy with the spacing for each, tighten the lock nuts.

Whether you like the single or double paddle version, you can build a very nice keyer paddle right into your rig. Best of all, it can be modified to fit into whatever rig you want, and can be built to suit you, in either style.

Given the choices of mono-band transceiver boards there are available today, you can select two of a design you like, for whichever bands you desire, and, with this scheme, build yourself a very nice two band, QRP sized, CW rig. For that matter, you could use this same switching configuration to build a two band QRP SSB rig with a couple of the small boards available today. This scheme can be used with any pair of transceiver boards that use pots and varicaps for VFO tuning. And, although the DSW series is now out of production, the SW+ series is still available.

Enjoy, Wayne NB6M Copyright 2000, All rights reserved

## **Operating QRP: It's a Contact Sport!**

by Michael A. Gipe K1MG  
12770 Lika Court  
Saratoga, CA 95070

### **Introduction**

Attention sports fans! QRP is NOT for sissies. It's a contact sport, and I'm not talkin' about QSOs. It's sprained wrists and ringing ears. If you're not prepared

for QRP, it's like:

**Playing football without a helmet;**  
**Climbing Mount Everest with-**

**out oxygen;  
Playing baseball without a  
glove;  
Or playing tennis without ten-  
nis shoes.**

Imagine an English football player stepping into an American football game, and you can imagine what it's like for a QRPer to set foot on the bands full of 2kw DXers and monster contest stations.

A QRPer has to be smarter, faster, and lighter on her feet. If you want to operate QRP, you've got to be in top condition – better prepared than the rest.

QRP is the ultimate proving ground for equipment and operator skills. Whatever the reason you choose to operate QRP, it is sure to provide more challenges, better training, and more fun than QRO. But you'd better be up to the challenge, and that means mastering the operating skills, choosing the right equipment and knowing how to use it properly, getting in condition, practicing, and having fun while doing it. Let's check out what it takes to be a real QRPer.

#### Personal Conditioning

Operating QRP is a sedentary sport, right? It's about as strenuous as watching a football game on TV while relaxing in your Lazy Boy with a brewski, right?

Ask any contester how he feels on Sunday night after a weekend contest. After all, a marathon runner gets to stop running after four to six hours, but a

ham radio contester has to keep going up to 48 hours with little rest. His voice or wrist is working the whole time, and he must be alert and quick in the stressful world of competition. His body is tense and poised at the key or mike for hours. He must maintain concentration without sleep. His bio-rhythms are completely disrupted. The QRP contester must work harder and concentrate more to keep his QSO rate up. Contesters suffer from hand or wrist fatigue, a worn out voice, and strained hearing.

One favorite activity of QRPer is carrying their radio stations out to the wilderness, where they can combine the fun of radio operating with hiking and camping. Besides the usual challenges to the body that these activities represent, the QRPer will be carrying radio equipment, heavy batteries, and an antenna in his pack. When the campsite is reached at the end of the day, he still has to erect the antenna.

One of the greatest challenges to the safety and health of an avid QRPer is the Family Hazard. If you are putting in the time to make a serious effort at QRP foxhunting, for example, your family may resent the time you spend at the rig. Family members may not realize how difficult contesting can be with interruptions, even short ones. And your family may not appreciate all the noises emanating from your radio while you chase DX at 3:00 AM. Being a QRPer and a responsible family

member requires proper balance.

Of course, we are all aware of the physical dangers of doing the QRP-L Fox Happy Dance without being in good physical condition.

All of which means that you've got to be in top physical shape to be a QRPer. Proper conditioning, preparation, and training are mandatory. Before that contest, strive to get in shape with a little daily exercise, plenty of sleep, a healthy diet, and a good dose of vitamins. You can't do your best in the Sweepstakes if you are tired, run-down, and loaded down with too many MacDonald's french fries. During the contest, take advantage of the rules concerning operating times to schedule frequent stretch breaks. Get out of the shack, move your body, and relax your mind for half an hour. The result will be better run rates and fewer busted calls in the log. Overcome the temptation to snack on potato chips and sodas during the test. Emphasize complex carbs, fruit, finger vegetables. Avoid excessive caffeine intake. You may need to keep the coffee pot going to manage to stay awake, but, for the sake of your fellow hams, try to avoid the overcaffeinated paddle syndrome, where your keying is so shaky that none of us can copy what you send. Protect your ears from fatigue by keeping the volume low, using AGC, and periodically shifting the sidetone frequency. Try switching filter bandwidths from time to time to change the tonal

character of the noise. To protect your voice, keep the humidity up and the temperature comfortable.

Before you set out from the trail head, consider carefully what you bring along. Scale down your ambitions for radio operations and vow to enjoy the hike, rather than swear at your pack all the way up the trail. Be aware of altitude sickness and how to treat it, including slowing your pace, drinking lots of water, and taking Tylenol. The best way to avoid altitude sickness is to plan your trip so that you have several days at intermediate altitude to acclimate your body before the hike. Choose the equipment you carry wisely. There are many trail-friendly QRP rigs available which are light-weight and easy on your batteries. Batteries are usually the heaviest part of the backpacker's station. Take time to calculate your power needs and choose the smallest, lightest battery solution that satisfies the requirements. It's also a good idea to divide your battery capacity into two sets, so you have a backup in case of unexpected discharge or failure of one set of batteries.

Remember that the amateur is balanced, and take your family's needs into consideration. Make a deal before the contest; in exchange for their promise of allowing you uninterrupted time to work the full contest, you will eschew ham radio for a full weekend to devote yourself to family activities. Be considerate, and arrange for quiet operation during the times

when normal people sleep. Perhaps the most effective way of maximizing your operating options is to become a retired widow or widower. Before you object, claiming limited finances, too young to retire, or healthy spouse, consider a high payout life insurance plan for your spouse. If you only need to pay the premium for a few months before becoming a wealthy early-retired widower, the cost is much less than a tower and tribander, and your country count will rise much faster. Just kidding, of course, but remember to take the time to enjoy your family before you become a retired widow with a country count over 300, with no one to talk to at home, and no memories to fall back on.

Work on improving your code copying speed. When the signals are weak, and the static crashes loud, you have an extra advantage when you are just loafing along speed-wise.

Whichever ham radio activity you enjoy best, doing it with QRP is more challenging and rewarding.

QRP operation can be hard on the body. It requires concentration and attention to copy weak signals in the noise. Keep your heart, hands, ears, and voice in good shape. And don't forget to practice that happy dance! You'll be glad you did.

#### Equipment

Many people enjoy QRP because of the simplicity of the equipment that you can use. It is

certainly a thrill to work stations across the country using a one-transistor rig that you just built. If you are going to wholeheartedly embrace QRP for all your ham radio activities, however, you need to carefully choose the equipment you use in order to get maximum satisfaction.

There is certainly no need to go out and buy an FT-1000 to be successful at QRP. In fact, although the Yaesu FT-1000 can be an excellent QRP rig, many standard HF rigs are not as good for QRP operation as some of the less expensive radios that you can buy or build that are specifically designed for QRP operation. Certainly, the concept of KISS (Keep It Simple Stupid) applies to QRP. Rather than choose a transceiver or antenna that has all the features, bells, and whistles, it may be best to select the transceiver with the specific features that are most useful for the kind of operating you intend to do. I've compiled a guide which lists some of those features and the ham activities that need them. Of course, these are my opinions, and you may have different ways of operating, so feel free to modify these based on your own experiences.

Some of my choices may require a little explanation, so let's examine the features of QRP rigs as they apply to various operating activities.

#### Rag Chewing

This is probably the most popular activity of the fraternity of

QRPers. Perhaps the best part is that you can do it and have a lot of fun with almost any QRP or QRO rig, from Pixie to FT-1000. About the only features that are absolutely necessary are the ability to receive and transmit, and a fairly stable VFO. Of course, your operating time will be more fun with a few additional options. The first thing you will appreciate is a good low-noise receiver. This means a receiver with a sensitive front end with a low noise figure. When the signals are weak and barely above the atmospheric noise, you don't want your receiver to add additional noise. Many commercial HF receivers are designed with the assumption that high natural noise levels, especially at the lower frequencies, will dominate the communications path; therefore it is not necessary to design a low noise front-end. This is probably true for most ham communications at 100 watts. However, QRPers tend to take advantage of those opportunities when the sun, our ionosphere, and the weather are cooperating to give us lower than average atmospheric noise. If your receiver is generating its own noise, you won't be able to take advantage of the opportunity. Phase noise, which is often the result of poorly designed frequency synthesizers, contributes to the total internally generated noise of a receiver, but it is of lesser importance for casual ragchewing than in other kinds of operation because its

main contribution to in-band noise occurs when the frequencies surrounding your QSO are filled with strong stations.

One often neglected part of the ragchewer's QRP station is the antenna. Although there are many adherents to the philosophy that QRP must mean poor antennas, I am strongly of the opinion that the QRPer should make the effort to assemble the most efficient and effective antenna system he can. QRP is about low power communication, not wasting power. This doesn't necessarily mean that you need to go out and spend thousands of dollars erecting a monstrous tower and beam. In fact, for reliable QRP operation, your money may be better spent on several simpler antennas and a switch to select the one which provides the best performance for the current QSO. While the DXer, intent on raising his country count, may be wise to invest in the tallest tower and biggest twenty-meter yagi he can find, the QRP ragchewer will probably be happier with a couple of wire antennas, placed high and in the clear, that he can select based on band conditions. At K1MG, I do have a tower and beam, as well as a vertical and G5RV. There are times when the G5RV outperforms the beam, and is the better choice for the QSO. We often forget that a non-resonant simple wire antenna, matched to the transmitter with a low-loss tuner, usually has a radiation pattern with multiple lobes

and nulls, and an equally complex elevation pattern. Although the nulls certainly make communications in certain directions difficult, the lobes can often provide gain which exceeds that of a decent yagi. My G5RV has a nice lobe in the direction of Arizona, as several members of the SQRPs can attest, which makes it the better choice when I want to trade stories with my friends there.

For rag-chewing, full break-in (QSK) operation is a nice feature to have in a transceiver. Certainly you can have lots of fine QSOs with a toggle switch for changing from transmit to receive and back again, but QSK adds another dimension. It adds to the conversational quality of a QSO, allowing the quick back-and-forth pattern of a face-to-face conversation. You can interrupt and respond immediately when the other operator asks a question. It also allows you to immediately recognize when that high-power RTTY station starts up on top of your QSO, so you can quickly QSY without losing the flow of the conversation. It can also save you from unneeded stress, such as might result from a need to heed the call of nature during your QSO partner's long-winded monologue. In fact, QSK allows you to change the subject when you get bored with that long-winded monologue!

RIT is another useful feature to have in the radio you use for casual rag-chewing. QSOs most often start when someone calls

CQ, and that person may have been you. If the reply to your CQ is not exactly zero-beat to your frequency, you may need to tune your receiver for best reception. However, you do not want to change your transmit frequency or you risk losing the other station, or you both end up leapfrogging down the band. RIT (receiver incremental tuning) allows you to tune your receiver in the vicinity of your transmit frequency, so that you can center your QSO partner in your receiver filter.

In the true spirit of QRP, many ops like to reduce power to the minimum necessary to comfortably maintain communications, so a transmitter with adjustable output power is a nice feature, though it is certainly not required. Along the same lines, an effective AGC system in your receiver is not required, but certainly makes operating more convenient. However, if you don't have AGC, you still have plenty of time in a rag chew QSO to manually set the RF and AF gain for best operation, even QSY if necessary when that kw station down the street comes on a few kilohertz away.

### **Contests**

You will find that the best station for contesting is quite a bit different from the ragchewer's station. Here, the QSOs are fast and furious, the bands are filled with lots of stations, many of them QRO, and they are located on all points of the compass. The demands on your station are tougher.

The first accessory you need to add to your contest station is a UTC clock. Whereas your wrist-watch set to local time may be all that you need to properly log your casual contacts, you need accurate UTC at hand to know when the contest begins and ends, and each contact must be accurately logged to count in your total score.

Your antenna system should allow you to make contacts in any direction. Here is where that high-gain yagi may be a big disadvantage. You are better off with several switchable wire antennas or an omnidirectional vertical antenna. An electronically switched phased vertical array may be the best contest antenna, since it gives you gain, reduced QRM off the back, and nearly instant changes of direction.

In your receiver, you will appreciate having a crush-proof front end and effective AGC. There will be a lot of very, very strong signals close to your frequency, and you don't have time for repeats or the ability to QSY to avoid them when they wipe out your receiver with poor dynamic range. Many QRP-only rigs have poor dynamic range, especially simple radios that use inexpensive low power first mixers like the NE602. Better receivers like in the NorCal 20 use better mixers and consume more power. AGC is used in these receivers to control the signal levels throughout the signal path so that the linear operating region is not exceeded when strong signals

are encountered. Tight filters are very useful for both SSB and CW contests, since stations will generally be packed into the band like sardines in a tin can. Low phase noise is a must. This is where many single band QRP rigs perform better than the commercial YaeKenCom rigs. Phase noise is the result of slight instability in an oscillator, and can be seen on a spectrum analyzer as wideband noise whose amplitude decreases as you move further away from the oscillator's main frequency output. Well designed oscillators with high Q tuned circuits exhibit less phase noise. A phase locked loop can reduce the phase noise of a less stable VCO; however, the VCOs and PLLs of many frequency synthesized transceivers may have higher phase noise than a well-designed narrow frequency VFO such as may be found in some single band QRP transceivers. Since the main frequency and the phase noise of a local oscillator both mix with incoming signals to produce an output at the receiver IF frequency, signals on the band that are many kHz away from the station that you wish to hear are also converted by the phase noise to the IF passband, albeit at a lower level proportional to the level of the phase noise. On a crowded band, the net effect is to raise the level of noise in the passband, possibly masking low level desired signals. In other words, if your receiver has poor phase noise performance, during a contest the



band will sound very noisy and many of the weaker signals will be wiped out by that noise.

Full QSK is almost a must in a CW contest. The exchanges are fast and furious, and there is no time to wait for slow T/R switching. You may be able to get by with fairly fast partial break-in operation. For SSB contests, a foot switch frees up your hands for logging and is faster than VOX. A memory keyer can save your wrist by freeing you from sending the contest exchange over and over again. Of course, you may wish to upgrade to full computerized logging and sending for the most efficient contest operation.

### **To the Field!**

Setting up a radio station away from home captures the interest of many hams, which explains why the ARRL Field day, QRP to the Field, and QRP Afield operating exercises are some of the most popular contest-like operations in the hobby. Without a doubt, the one most important element of your field station is the battery. Without a proper battery or with an inadequate battery, your operation will not be successful. On the other hand, carrying too large a battery to a remote site can be seriously hazardous to your health. Years ago, I used to carry a full size, marine deep cycle, lead acid battery to our field day sites at the beach or in the hills. In the years since, batteries seem to have gotten heavier and I have gotten smarter, so I now prefer lower

power and small gel cells or nicad batteries. Nearly every field station needs a battery, even if it is only used to supply the peak transmit currents which your solar or wind generator can't handle. Take the time to calculate exactly how much battery capacity you will need for your planned expedition, and be sure to take into account the weight of the batteries that you must carry into the field.

Of course, even a lightweight battery is no good if the radio itself is too large or heavy to carry, or if it consumes too much battery power during receive. Although many commercial radio manufacturers have introduced small transceivers like Icom's pioneering IC706, these all consume a lot of current even while receiving, perhaps as much as half an amp from your 12 volt battery. Compare this with some of the QRP rigs designed by N6KR, NN1G and others for field use. Some of the more efficient of these use only 0.025 amps during receive. Since the majority of your time on the radio is spent receiving, an efficient receiver can save a lot of battery weight. Usually, in order to achieve low receiver current, you must compromise dynamic range, but in field operations away from populated areas, this is much less important.

Your field antenna should be easily broken down and carried as well as light in weight. Wire antennas are generally the rule except for a few overambitious Field

**Day club stations.** Trees provide excellent support for such antennas if they are around and you have brought along a means for stringing the support ropes high up in the trees. Sling shots, bows, and weighted heaving lines have all been used successfully, as well as the occasional spud cannon. What if your hike takes you to a treeless place? Be sure to bring an antenna support with you, too. Lightweight collapsible fishing poles can often be used to support a horizontal or vertical wire antenna. One of the nice advantages of field operation is the ability to pick an excellent antenna site, taking advantage of altitude or terrain to make a simple and inexpensive antenna outperform a monster home station antenna. One more point to remember is that resonant antennas can save weight by eliminating the need for a tuner.

Once you have reached your destination, you won't want to return to pick up supplies or equipment that you forgot, and you certainly don't want to carry unreliable equipment. So before you leave, check out all your equipment that you intend to bring, making sure that you have safely packed all the cables, connectors, and other accessories needed to operate. Provide a secure means of carrying the batteries so that there is no opportunity to short their terminals. Test your transceiver so that you know how it behaves as the battery reaches the end of its charge. Will the rig become unstable be-

low eleven volts? Will it operate down to ten volts with lower power out? Test everything beforehand, pack it up, then leave it alone until you are ready to leave.

Generally, most field operation takes the form of either contest style operation or rag chewing/keeping in touch with home. You can tailor the station to fit the needs of the intended operation, but the requirements for low total weight and reliability are paramount.

### **DX Pileups**

Avid DXers can't resist them; even non-DXers find themselves drawn to a massive pileup on top of a rare country. Do you need to invest thousands of dollars in your station to be able to play in the pileup? No, what you need is fine-tuned operating skills and a few special equipment features. The most important thing you need for pileups is the ability to operate split frequency, where you transmit on a frequency different from where you are listening. This is sometimes referred to as dual-VFO operation. Most of the time the DX transmits on one frequency and listens for responses over a range of frequencies above his transmit frequency. This keeps the pileup from covering up his transmissions. This is common practice for both SSB and CW operation. If you don't have the ability to separate your transmit and receive frequencies, you will probably be unsuccessful at making a QSO at best, and branded a LID by the

other stations at worst. Split operation permits you to park your receiver on the DX station so you can always hear him, then move your transmitter to where he is listening. It also allows you to quickly swap frequencies so that you can listen to the other stations working the DX and check out your own transmit frequency to make sure it is reasonably clear. Some high-end commercial transceivers allow you to operate with two receivers simultaneously, one glued to the DX station, and one tuning around for the best spot for you to transmit. Generally, each receiver feeds one ear, so you can keep them straight. Unfortunately, most QRP radios do not have split operation available. You can make do with RIT or XIT in this case, but it is much more difficult. XIT is more useful, and the ability to quickly switch between RIT and XIT is very helpful. Hopefully, the development of more sophisticated QRP transceivers such as the Elecraft K2 and the adoption of recent technologies like DDS (direct digital synthesis) will make split operation more common in QRP radios.

Besides split operation, your radio should have a pretty rugged front end, with good dynamic range and effective AGC. After all, the combined power of a pileup is probably close to a megawatt! Full QSK will save you from embarrassment from transmitting at the wrong time. Most DX ops work through a pileup quickly, and you

can't wait for a sluggish T/R changeover.

Narrow bandwidth filters are usually not necessary, since most operators are careful to stay clear of the DX's transmit frequency where you are listening. A good UTC clock will be helpful, since you don't get a QSL if you logged the time wrong. Many DX stations, especially DXpeditions, have good antennas and operate at fairly high power, so the demands on your receiver are fewer.

For your antenna, put up the best, most efficient, single antenna you have space and money for. For the diehard DXer, this usually means a tall tower and big yagi, but simple antennas can work too. Verticals are good due to their low take off angle. However, it is important to make your antenna system efficient – every watt lost in poor feedline, an inefficient tuner, corroded connections, or an inadequate ground system reduces your success.

### **QRP-L Foxhunt Pileups**

It has been said that the QRP-L foxhunts are excellent training for chasing DX. I think that DX pileups are excellent training for the foxhunt. After several years of foxhunting, the hounds have gotten smarter and more skilled than the everyday DXer in a pileup. However, the equipment requirements are much the same, with only a few minor differences. You can get by without split or RIT/XIT because all the foxes will work a considerate operator who is

zero-beat with their signal. Because of this, you may find you need some tight filters to be able to separate the fox's signal from the hounds. In addition, sometimes a wide filter helps to copy a weak fox because your brain and ear can perform some pretty miraculous signal processing to pull a signal out of the noise if it has a full bandwidth signal to work with. For the antenna, you may find that having two simpler antennas is better than one high-performance antenna for the simple reason that the foxes are spread across the country and you may need to pick the antenna which best matches the propagation conditions during the hunt. I once worked a fox who could only hear me when I was transmitting on my horizontal dipole, but I could only hear him on my vertical. It made for some pretty complicated changeovers, but having both antennas available made a QSO possible. Don't forget, full QSK is necessary if you want to avoid the embarrassment of stomping on the fox's toes.

#### Operating Smarter

The key to QRP success is to operate smarter. By using our finely developed skills and keen minds, we can play the game surrounded by kilowatts and not only survive, but thrive. Half of operating smarter is just common sense; the other half is learning and using the skills and techniques that have been developed over the years by A1 operators. Did you ever wonder how something as un-

common as common sense got its name?

Like any sport, QRP requires a combination of skills, knowledge, equipment, and attitude in order to excel.

#### Skills

The topic of operating skills for QRP operation is so big that you could write a book about it. In fact, somebody already has. In my opinion, *the* training manual for QRPers who want to improve their skills for rag chewing, DXing, contesting, fox hunting, and having fun in general is Bob Locher's book, *The Complete DXer*. A book on DXing? Yep. I reread my copy often, and never fail to learn or relearn some good lessons. Get it. Read it. Do it.

One of the most fundamental axioms of operating is that you must be transmitting on the frequency where the other station is listening. Sounds pretty simple, doesn't it? If his receiver isn't tuned to your transmit frequency, he won't hear you, regardless of your power output or antenna gain, or even an intense need to get a QSL from his country. Certainly, only an idiot would attempt to initiate a QSO by transmitting where the other station was not listening, but actually it happens all the time. First, you have to figure out where his receiver is tuned without standing behind him and looking over his shoulder at the control panel on his transceiver. Next you have to figure out how to place your transmitted signal at that same fre-

quency. Let's look at these jobs one at a time.

How can you tell where his receiver is tuned? We can only make an educated guess, of course, but the more education we have, the better the guess. First off, most QSOs between two stations occur or ought to occur on one frequency, with each station transmitting and receiving on the same frequency. So if you hear a station calling CQ, chances are good that he is listening on the same frequency that he is transmitting. Of course, there is always the possibility that he left his RIT on accidentally, or has somehow mistuned his transceiver, or not properly spotted his transmitter to his receiver. If he is just finishing up with a QSO and you want to call him, you can adjust your transmitter so that you exactly zero-beat (set to the same frequency as) the other station he was talking with. You can be fairly certain that if he was copying him during the QSO, his receiver will be set to that frequency. Let's say that you can't hear the other station, or he has just come up and called CQ, and you were unsuccessful at getting his attention by calling on the frequency you expected him to be hearing. Instead of concluding that your QRP signal is too weak and giving up, try shifting your transmitter up or down a couple hundred hertz and trying again. Occasionally, you may come across a station using a very simple QRP transceiver which

does not have a built-in transmit offset such as the Pixie or 49er. In this case, calling him approximately 600 Hz above or below his transmit frequency may catch him. The point is, before you give up, make sure you have exhausted all the possible reasons why he might not be listening to the frequency of your transmitter.

Desirable DX stations, foxes, and some special event or contest stations may be working an offset. This means that the station is intentionally listening and working other stations at a frequency substantially different than his transmit frequency. Usually he will let you know this by adding the phrase "up 2" or "up" on CW, or "listening 14200 to 205" on SSB. If you go to the indicated frequency, you will most likely encounter a nice big pileup. Tune around the pileup and listen for a while. If it is for a rare country, you will most likely hear several stations calling on the DX's frequency, and a whole bunch of stations calling in a swath of frequencies five kHz wide or more. If the rule is, call the station where his receiver is tuned, then why are these people transmitting over such a wide range? If everybody followed the rule, everyone would be stacked on top of each other on the same frequency where the DX's 100 Hz receive filter would pass it. Fortunately for the QRPer, most people go the lazy route and try to substitute brute force and repetition for smarts. This is where

the smart QRPer has the 10 S-unit advantage over a kilowatt! If your one watt signal is centered in the DX receiver passband, and the 1.5 kW signal is 2 kHz lower, which one of you will get the QSO? What does the smart QRPer know about the DX's receiver that all those other people don't know? You know where he's tuned because you've listened and figured it out. The first conclusion you make is that his receiver was just tuned exactly to the frequency of the guy he just finished a QSO with ("K1MG 599 tu"). I assume at this point that you have set your transceiver to split or XIT, and you have centered the receiver on the DX station with VFO A. Never change that setting. Now swap VFOs or switch XIT to RIT, and tune around to find the lucky DXer finishing up his QSO ("tu ur 599 de K1MG/ QRP"). If you now swap VFOs or switch RIT to XIT, you have about an 80% chance of hitting him right between the skirts of his filter. For the other 20%, you have to listen a little bit more to find his pattern of receiving. Listen some more and keep searching for the stations he calls. Some DX stations run a pattern through the pileup, the most common being to tune up a little between each QSO until the top of the pileup is reached, then starting again at the bottom. Another common pattern is to alternate two frequencies. If you can figure out his pattern, you will be one of the few people in the pileup who know where he will be listen-

ing for the next QSO, and you can just drop your call on that frequency and collect your prize, I mean QSO. Of course, there are refinements and more advanced techniques, but the whole goal is to put your signal where the other guy is known to be listening. Instead of jumping into a pileup and calling blindly for twenty minutes, try listening carefully for fifteen minutes and making one call to grab the QSO!

Naturally, all this attention to figuring out where the other station is receiving is just wasted effort if you don't know how to set your transmitter to that frequency. This is known as zero-beating the station. The name came from the era where receivers had adjustable BFOs, and you could set the BFO to the center of the IF filter passband. Then you tuned your receiver so that the tone of the station calling dropped to zero cycles per second. Finally, you tuned your transmit VFO to the same zero frequency tone. If it was a little off of the other guy's frequency, his signal and yours would mix or "beat" together to produce a slow pulsing sound. If you tuned the VFO so this pulsing slowed and stopped, you were zero-beat with the other station. With most modern transceivers, the BFO is fixed so that a specific tone is generated when the signal is centered in the passband of the filter. The transmit VFO is automatically offset exactly the right amount to match this. The key-

ing sidetone generated locally by the transmitter is set to this same frequency. All you have to do is tune the other station in so that his signal has the same pitch as your keying sidetone, and you are automatically zero-beat. Although most transceivers do this, a few, particularly simple rigs like the Pixie or 49er, do not. Therefore you must know how your rig works and know how to zero-beat it a signal correctly.

The corollary to transmitting on the frequency where the other station is listening, is to call the other station *when* he is listening. Again, this sounds stupidly simple, but folks violate this rule all the time. How often have you been dismayed because you couldn't copy the DX station or the Fox because somebody else was busy repeating his own call sign over and over on top of him? Simply stated, when the Fox or DX is transmitting, he is not going to be listening to anybody! The smart QRPer listens long enough to get into the rhythm, always stops transmitting when the other station starts, and times his own calls to the exact time the station is listening. Of course, you are using QSK so you can tell if the DX starts transmitting while you are still sending, right? To catch a fox, you need to tune your timing to the milliseconds, so stay alert and practice.

The most important skill a QRPer can have is listening. Listen to learn. Listen to the pileups to find out what successful stations

are doing to be successful. Listen to figure out how the propagation is changing on a band. Listen to find those lonely DX stations that are calling CQ 10 kHz away from the awful pileup at the bottom of the band. Listen to find out what you can about the station you want to contact. Just by listening to the string of "599 tu's", you can sometimes figure out what equipment he is using, what kind of antenna he has, and a whole host of useful facts. Every transmitter has a characteristic sound and every operator has a distinctive fist or voice that you can discern by careful listening. I was once hunting a distant and weak fox, and having a difficult time making myself heard above the hordes of Texan hounds. At one point, the fox was forced to QSY because of sudden RTTY QRM. He made a quick announcement that he was QSYing and disappeared. I quickly tuned up to a quiet spot where I thought he might land, and listened while a weak station sent "QRL?" I recognized his fist, and caught the pelt before he identified and before anyone else knew he was there. There are lots of things you can learn by listening, things you can then exploit to give yourself an advantage, whether you are trying to overcome the roar of a pileup, the inexperience or nervousness of a brand-new ham, the ravages of QSB on your puny signal, or Murphy's tricks.

While we're on the topic of skills, let's not forget the basics.

When the going gets rough, and the band is noisy, that extra practice to raise your code speed will help. If your brain is coasting along with the code, it can concentrate on pulling the dits and dahs out of the noise. If you know the common CW procedures and abbreviations, they won't throw you for a loop while you dig that weak one out. If you know how to use all those buttons and knobs on your transceiver without thinking about it or referring to the manual, your operating will be easier and more fun. If you learn the distinctive sounds of signals undergoing the strange process of around-the-globe propagation, if you learn what 40 meters sounds like when it is about to "go long", if you teach yourself to copy lousy fists or exaggerated swings, you'll get a lot more enjoyment from the hours you spend at low power.

There are a lot more tricks and techniques, but I have to save a few for myself when I come up against you in the fox hunt!

### **Knowledge**

In the thirty-plus years since I was first licensed, scientists have amassed a wealth of knowledge about the sun and how it affects radio wave propagation on earth. What was once a vague concept of correlation between the number of sunspots and the frequencies that the ionosphere reflected has turned into a fairly well-understood system of cause and effect. These days, you are as likely to hear QRPers talking about CMEs

and geomagnetic disturbances and M-class flares as you are to hear them talking about SWR and output power. A good part of this understanding has come from the excellent tutorials that Paul Harden NA5N has presented at various forums, including the internet QRP mailing list. This knowledge allows the QRPer to determine the best frequency to use and when to use it. It also helps you understand what is happening when the bands seem to get "weird", or when 40 meters is dominated by static crashes. It can give you a clue to when conditions will change for the better. Such understanding leads to more success with low power.

Another resource that helps you to know the current state of the ionosphere is the network of beacons that has been installed by the Northern California DX Foundation. Located at spots around the world, these beacon transmitters are carefully synchronized using GPS time receivers so they take turns transmitting on the same frequency. In three minutes, you can determine the state of propagation from your QTH to nearly any region of the world. One of the nicest features of these beacons is the fact that they transmit a sequence of signals at 100, 10, 1 and 0.1 watts, so you can get a very good idea of how well your QRP signal will be heard around the world. The beacons also operate on all bands from 14 MHz to 29 MHz, helpful for deter-



mining the best band to use.

Did you ever look at the scores from a contest and wonder why some guys made fewer QSOs than you did, but somehow earned a higher score? It's probably because they read the rules very carefully and figured out a strategy that took advantage of some of the features of the rules. For example, many contests combine the multipliers from all bands into one which is applied to the total QSOs. In this case, trying to get at least a few QSOs on each of as many bands as possible can quickly boost your score faster than running hundreds of stations on twenty and forty meters. Check out the rules for the QRP contests. You may find that the extra multiplier you get for one watt or less, more than makes up for a slightly lower QSO count at the lower power.

While we are on the topic of contests, did you ever notice that the semi-annual North American Sprint, famous for attracting the top echelon of contesting over-achievers, has a unique set of rules that strongly benefit QRPers? The QSY rule makes it impossible for those kW behemoth stations to dominate a frequency. In fact, those S9+60 stations actually serve as beacons to draw others to your signal. Read the rules and check it out!

### **Equipment**

A Pixie connected to a yagi antenna on a 60 foot tower with low loss 9913 coax will outperform

a Yaesu FT-1000 connected to a dummy load every time. Yet both of these stations cost about the same amount of money. You may not want or be able to spend that much money to assemble a station, but where should you apply the dollars you have budgeted? The three most important secrets to QRP success are 1.) antenna system, 2.) antenna system, and 3.) antenna system. This includes your tuner, feedline, antenna, antenna mounting, and grounding. When you have only a few watts to start with, it is very important that you don't lose too many of them along the way to launching them into the ether. I recommend low-loss feedlines for home stations. I use 9913 and open wire line at K1MG, and other notable QRPers take similar approaches. It is helpful to understand the origin of losses in the antenna itself, and how they can mask a poor match to the feedline. I highly recommend that you model your antenna farm, home QTH and portable, already installed or still in the planning stages, with a computer modeling program such as W7EL's EZNEC. Try variations to see what effect they have. You will quickly garner a number of insights, such as why vertical antennas work wonders at the beach but may be disappointing at your mountain-top home, why some electric fence wires may make a better dummy load than antenna, and why center loading may work more efficiently than base loading.

It will also tell you that there is no substitute for altitude when it comes to HF antennas. You can also learn how to take advantage of geographic features, like the three hundred foot dropoff at your QRP-To-The-Field site.

On CW, use full QSK! There's really no excuse anymore. I want to be able to interrupt your monologue when I get bored, and vice versa.

Make sure you know how to use your radio. It sounds rather silly. After all, you've been using it for years. Do you know how to accurately zero-beat another station? Do you know how to switch it to receive on the other sideband for CW? Do you know when you would want to do that, and what happens to the frequency readout when you do? How can you optimize weak signal reception? You can often improve the signal to noise ratio by turning off the AGC, turning the AF gain all the way up, and adjusting the RF gain for best reception. What effect does your noise blanker have on that S9+60 signal that's only 3 kHz down the band from you? You may find that it adds tremendous intermodulation distortion that spreads that kw signal over many tens of kHz. How do the filter characteristics affect the copyability of a signal. Sometimes a station may be strong enough to easily hear, but hard to copy because of distortions introduced by the IF filter. You may find that a wider filter, or moving the signal to another

part of the passband may improve copy dramatically. How well do you know your rig?

### **Attitude**

Adopt a winning attitude. QRP means low power, not low scores or second-rate success. Many hams only answer a station calling CQ which is S7 or above, thinking that the weaker stations won't hear their pipsqueak signal. I suggest you go searching for the weak signals – push the envelope! Think Extreme Sports! QRP is about testing the limits of the sport of ham radio, but it's much safer than skateboarding while skydiving. Above all, go into it with confidence. You won't be successful all the time, but you will get through more often than you think. Set your own goals. Compete with yourself. Try to beat your score from last year in this year's contest. Try to work all fifty states with two-way QRP. Then try it with less than a total cumulative power of 5 watts. How about WAS using two-way QRPP? Push yourself; push your station, and above all, go at it with a winning attitude!

To round out that winning attitude, add a dose of patience, tolerance, and courtesy. These go a long way towards making your hobby fun and satisfying, for you and your fellow hams.

### **Training and Practice**

As with any sport, training and practice are essential for success when operating QRP. Don't forget any aspect of your training,

including physical condition. Jump into those DX pileups; they are great practice for the serious sport of QRP-L foxhunting. For exercising your code proficiency, there are a number of programs available for the PC. One that comes highly recommended by top operators is RUFZ, available for download on the internet. But most importantly, shut off that PC once in a while and get on the air and operate! Getting in the game is the best way to improve your skills.

#### Summary

Nothing beats QRP for pure fun in ham radio, and nothing offers more of a challenge to your skills and training than operating QRP. Just do it!

#### References

##### **DXing and operating in general:**

Locher, Bob W9KNI, *The complete DXer*, 1983, Idiom Press, Deerfield IL

##### **The ultimate source for QRP info:**

QRP-L, the Internet QRP mailing list. See <http://qrp.cc.nd.edu/qrp-l> for signup info

##### **Antennas and Tuners:**

Witt, Frank AI1H; *How to Evaluate Your Antenna Tuner*, QST, Apr-May 1995, Newington CT

Cebik, L. B., <http://www.cebik.com>

Lewellyn, Roy W7EL, EZNEC antenna modeling software, Beaverton, OR

##### **Propagation:**

Harden, Paul NA5N; propagation reports to QRP-L, several ham conference presentations and journal articles

Northern California DX Foundation Beacon Network; <http://www.ncdxf.org/beacon.htm>

##### **Code training:**

RUFZ, <http://www.darc.de/referate/dx/fedtr.thm>

Many other PC based programs

W1AW, Newington CT (schedule in any QST)

# LEARNING ELECTRONIC CIRCUITS FROM THE "DESERT RATT" REGEN RECEIVER

Paul Harden, NA5N  
NA5N@R166.com

The "Desert Ratt" is a simple regenerative short wave receiver you can easily build. In spite of its simplicity, it works quite well. Additionally, it contains almost every basic circuit building block (except for a mixer). So let's look at these simple stages to better understand how they work. Hopefully, it will take some of the "magic" out of understanding these circuits and show some of the design steps involved.

## ① THE UGLY TRUTH BEHIND FILTERS (They're Easy)

$C1-L1-C2$  forms a HIGH PASS filter (HPF), with a 3-dB cut-off around 3MHz, to reduce interference from AM broadcasting.

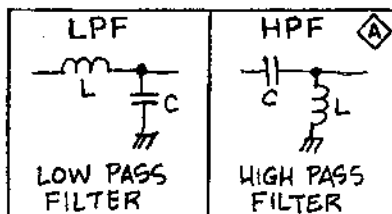

A LPF/HPF is just a voltage divider - where one (or both) of the "resistors" are replaced with frequency sensitive components - namely an inductor or a capacitor.

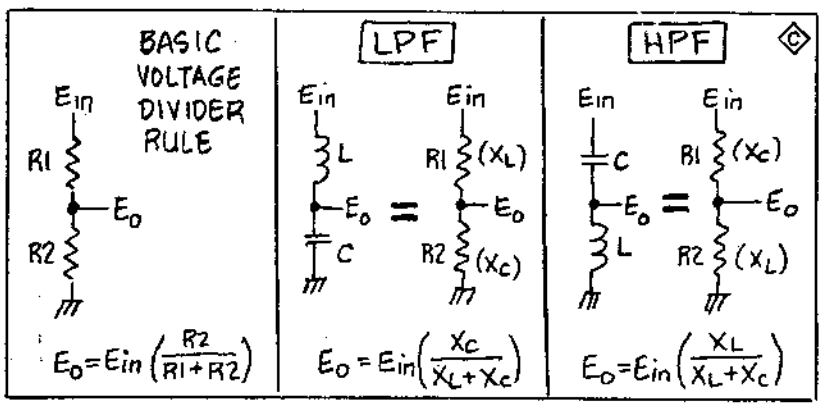
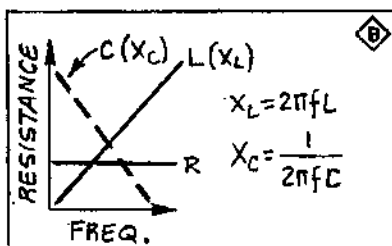

Let's analyze HPF C1-L1.

$$C1 = 200\text{pF} \quad L1 = 15\mu\text{H}$$

The 6dB (half-power) point is where  $X_C = X_L$ . This also defines resonance ( $X_C = X_L$ ). Thus, the same equation is used to find the 6dB point of an L-C filter

$$f_{6\text{dB}} = \frac{1}{2\pi\sqrt{LC}}$$

$$= \frac{1}{2\pi\sqrt{15\mu\text{H} \times 200\text{pF}}}$$

$$= 2.9\text{ MHz}$$

NOTE: 3dB = 1/2 for power  
6dB = 1/2 for voltage

To make a filter response plot, calculate  $X_L$  and  $X_C$  at several frequencies above and below the  $f_{6\text{dB}}$  point, then  $E_o$  from FIG. C

MHZ	1	3	5	10
$X_L =$	94 $\Omega$	283	471	940 $\Omega$
$X_C =$	796	265	159	80 $\Omega$
$X_L + X_C =$ ( $R1 + R2$ )	890	548	630	1020
$E_{in} =$	Calculate using IV			
$E_o =$	.1V	.5V	.75V	.9V
dB	-20	-6	-2.5	-1dB

RESULTING PLOT

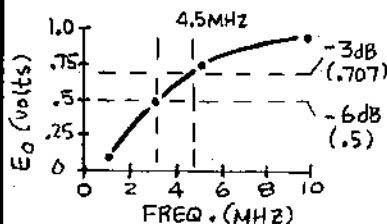

HINT: It's real easy to do this with a spreadsheet.

For a LPF - everything is the same except  $E_o$  is across the capacitor, not an inductor. See FIG. A.

Now - say you don't have a 15 $\mu\text{H}$  inductor. You only have a 4.7 $\mu\text{H}$ . Let's make the same HPF with the 4.7 $\mu\text{H}$ .

HPF DESIGN STEPS.

1. Choose the 3-dB "pole" to be the same 4.5MHz (see response plot)
2. 6dB point (where  $X_L = X_C$ ) will be 4.5MHz  $\times$  .707 (3dB) or 4.5MHz  $\times$  .707 = 3.2MHz
3. Calculate  $X_L$  for 3.2MHz  
 $X_L = 2\pi \times 3.2\text{ MHz} \times 4.7\mu\text{H}$   
 $= 94\Omega$
4. Find capacitor where  
 $X_C = 94\Omega$  at 3.2 MHz

$$C = \frac{1}{2\pi f X_C}$$

$$= \frac{1}{6.28 \times 3.2\text{ MHz} \times 94}$$

$$= 529\text{pF (use } 560\text{pF)}$$

For LPF - same steps as HPF except to find L (step 4)

$$L = 2\pi f X_L$$

C2 ac couples the signal to the next stage and is customary to make  $C2 = C1$ . Although any value will work. However, smaller the value, the less loading to the LPF/HPF filter.

## ② Q1 - THE RF AMPLIFIER

The RF amplifier provides signal gain and helps to isolate the Regen stage from the antenna (so it's not a transmitter). With no tuned circuits, Q1 is a simple wide-band amplifier.

### DESIGN STEPS

1. Choose operating point  
 $V_c = \frac{1}{2} V_{CC} = 4.5V$  (4V BATT)  
 $I_c = 2mA$

2. Calculate collector load  
 $R_c = R_2 = \frac{V_c}{I_c} = \frac{4.5V}{2mA} = 2.2K$

3. Calculate  $R_1$  to forward bias Q2 ( $V_{be} \geq 0.7V$ )

$$R_2 = \frac{V_c - V_{be}}{HFE} = \frac{4.5V - 0.7V}{50}$$

$$= 180K \text{ (use } 200K)$$

Where HFE = the DC current gain of Q1, which is about 50-100 for the 2N2222, 2N3904, etc.

This scheme is not a very good amplifier (just simple). Let's see why not.

$$R_{in} \approx \frac{26 HFE}{I_E (mA)}$$

← varies with HFE      ← varies with HFE

and the voltage gain is

$$A_v = \frac{R_c}{R_e}$$

← varies with HFE

Since emitter is grounded (no  $R_E$ ),  $R_E = PN$  junction resistance,  $r_e$ , which varies also with HFE.

Thus, the gain of this amplifier depends on the HFE of the transistor, not the biasing or external components. HFE changes between one transistor and the next - so by finding a "hot" HFE transistor - you will get higher gain. This is OK for "one of a kind" projects, but not for production (or a kit!)

A good amplifier design includes "stiff" biasing, "fixes" the  $R_{in}$  and an emitter resistance - all to control the gain.

In the Desert Ratt, gain is controlled partially by  $L_2$ , which shunts  $R_2$ , to lower the gain, but make it higher at higher frequencies, where the sensitivity of the regen stage falls off.

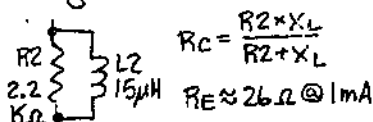

At 6 MHz,  $X_L = 565$

$$R_c = 2.2K \parallel 565 = 450 \Omega$$

$$A_v = 450 / 26 = 17 \text{ (25dB)}$$

At 12 MHz,  $X_L = 1130$

$$R_c = 2.2K \parallel 1130 = 746$$

$$A_v = 746 / 26 = 29 \text{ (29dB)}$$

### ③ Q2 - THE REGEN STAGE

The Desert Ratt uses a regen stage designed by Charles Kitchin, NITEV. It is a clever circuit producing a "soft" regen far more suitable for AM detection than most regen circuits:

Q2 is actually a common-base amplifier, which has these characteristics:

- No current gain
- High voltage gain \*
- Prone to oscillation at high gains. \*

\* Items exploited for a regenerative amplifier

The DC CURRENT flow thru Q2 is shown in FIG. D.

DC CURRENT FLOW  
(Common Base Amplifier)

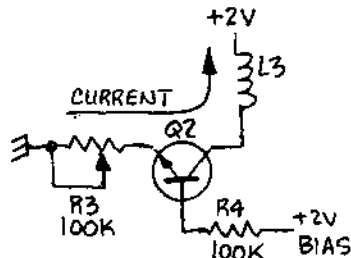

The base is biased ~2V to cause conduction. The amount of current flowing through the collector and load L3 is set by R3, the emitter resistor. The lower the value of R3, the HIGHER the gain.

AC SIGNAL FLOW

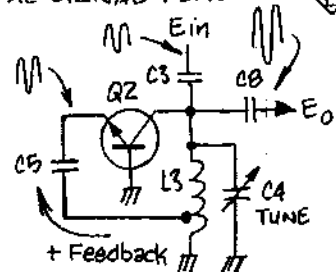

The input to a CB amplifier is to the emitter, not the base like the CE amplifier. The input from the Q1 RF amplifier is applied to the L3-C4 resonant circuit via C3. The signal is tapped off L3 and becomes the Q2 input via C5. Note the feedback signal to Q2 emitter is IN-PHASE to the input signal forming POSITIVE feedback. The feedback signal to the emitter is amplified by Q2. The amount of gain is determined by R3.

The amplified output from Q2 is added to the input signal at L3, tapped off and applied to the emitter, amplifying the signal further. This additive (regenerative) amplification continues until the Q2 circuit goes into oscillation. By reducing the gain with R3, a point of

extremely high gains, just before oscillation, are achieved. Voltage gains of 100,000-200,000 are typical, even with only the 2V Vcc. Unlike the other amplifier circuits, there are no equations to calculate the voltage gain of a regen amplifier stage.

For the AC signals, the base is grounded through C6 and L3 is grounded by C7.

However, the tuning range of the receiver is calculated from the resonant circuit L3-C4:

$$f_r = \frac{1}{2\pi\sqrt{L3C4}}$$

C4 min = highest freq.  
C4 max = lowest freq.

#### ④ THE L3-C4 "TANK" CIRCUIT

Part of the fun of building the Desert Ratt is winding different coils for different frequency ranges. The feedback tap should be about 1/3rd of the total

windings for good feedback. Adding a capacitor across C4 (parallel) will lower the frequency, while adding capacitance in series with C4 will narrow the tuning RANGE.

#### ⑤ D3-D5, A POOR MAN'S REGULATOR

What makes the NITV regen stage to have such smooth regeneration is operating the stage from only 2V. D3, D4 and D5 act as a 2V zener regulator. Each diode drops ~0.7V, times 3 for about 2V.

It will stay at 2V, even when the battery voltage drops well below 9V.

R5 must drop the remaining 7V. The current thru the regulator is

$$I = \frac{E}{R} = \frac{7V}{150K} = 47\mu A$$

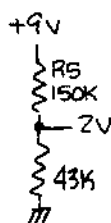
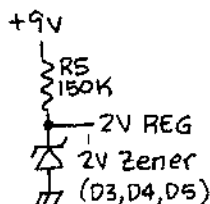

Remember the voltage divider rule in FIG. C? This can be used also to make the 2V, although the point of regen changes as the battery discharges.



## ⑥ Q3-EMITTER FOLLOWER (E.F.)

At proper regen, Q2 has a high Q and output impedance. When the detector diode is conducting, it has a low impedance - which loads down the Q2 stage, lowering the Q and the gain. I added the emitter follower to isolate the detector from the Q2 regen stage.

An emitter follower has NO GAIN. So what good is it? Well, it has a high input resistance and a low output resistance - and can be used as an "active" transformer.

### DESIGN STEPS

1. Choose  $V_E = V_0 = \frac{1}{2} V_{CC} = 4.5V$
2. Choose  $I_C = 1mA$
3.  $R_E = R_B = \frac{V_E}{I_C} = \frac{4.5V}{1mA} = 4.5K$
4.  $V_B = V_{be} + V_E = 0.7 + 4.5V = 5.2V$
5.  $I_B = \frac{I_C}{HFE} = \frac{1mA}{100} = 10\mu A$
6.  $I_{BB} \approx 2$  to 10 times  $I_B$   
at 2.5 times =  $25\mu A$
7.  $R_{bias} = R_6 + R_7 = \frac{9V}{25\mu A} = 360K$
8. Need  $V_B = 5.2V$  across  $R_7$   
 $R_7 = \frac{V_B}{I_{BB}} = \frac{5.2V}{25\mu A} = 208K$  (220K)
9.  $R_6$  drops remainder  
 $R_6 = \frac{9V - 5.2V}{25\mu A} = 152K$  (180K)

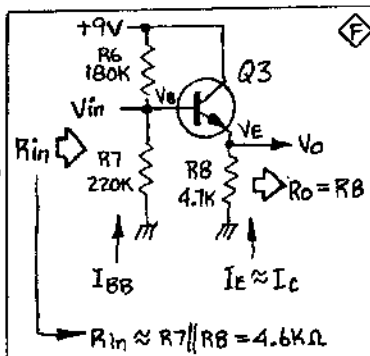

$$R_{in} = R_7 || R_B = \frac{220K \times 4.7K}{220K + 4.7K} = 4.6K\Omega$$

Thus, input resistance is dictated by  $R_E$  ( $R_B$ ). So make  $R_B$  relatively high.

Biasing is not critical.  $R_6$  and  $R_7$  are often made the same values to save the DESIGN STEPS #5-9. For example,  $R_6$  and  $R_7$  could both be 100K to 200K  $\Omega$  and still produce about the same base current.

### EXTRA CREDIT

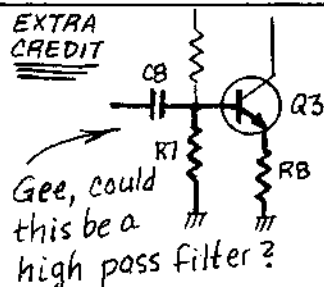

YES!  $C_B$  with  $R_{in}$  ( $R_7$  parallel to  $R_B$ ) forms an unintentional High Pass Filter.

$$f_{3dB} = \frac{1}{2\pi RC} = \frac{1}{6.28 \times .005 \times 4.6K\Omega} \approx 7KHz$$

## ⑦ D1, D2 - THE A.M. DETECTOR (Not to be confused with PM detector!)

The original Desert Ratt used a single IN34 germanium diode detector (half-wave) while this version employs a 2-diode full-wave detector for higher audio recovery.

Germanium diodes should be used (IN34, IN270, etc.) due to their lower forward voltage drop over silicon diodes.

### WHY GERMANIUM DIODES?

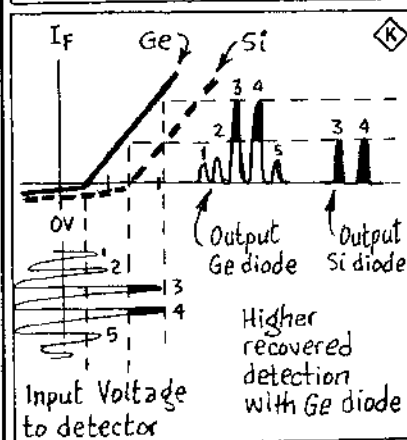
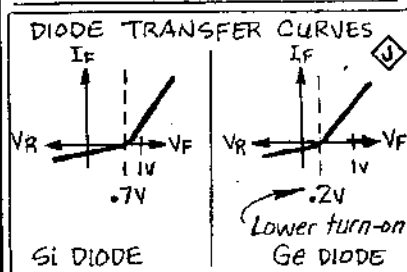

The lower forward volt. drop ( $V_f$ ) of Ge diodes allows more of the input voltage to be rectified and recovered.

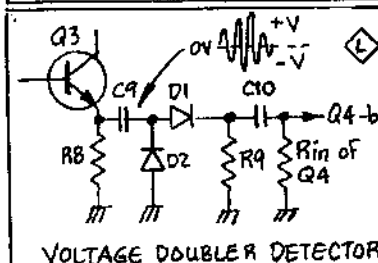
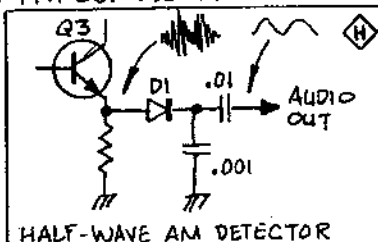

In the full-wave/volt. doubler circuit, D2 conducts during the negative (-V) portion of the signal. This makes more charging current thru C9 and C10 for higher average detected audio across load resistor R9.

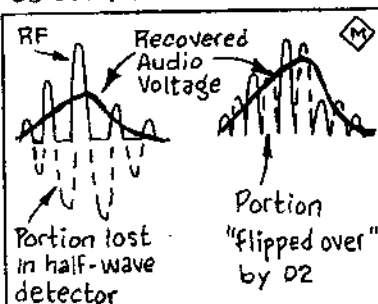

Each cycle of the RF signal is converted to positive voltage "pulses," which charges C10 to the average voltage by the time constant of C10, R9 and Q4 Rin. This is the audio.

## ⑧ Q4 AUDIO PRE-AMPLIFIER

Q4 is a very common audio amplifier circuit. Base bias of ~2v comes from voltage divider R10-R11. Calculated gain is:

$$A_v = \frac{R_c}{R_e} = \frac{R_{13}}{R_{12}} = \frac{1.6K}{220} = 7 (17dB)$$

With a moderately strong shortwave station tuned in, there will be 10-20mV of audio from the D1-D2 AM detector. This will be amplified to around 100mVpp, which is sufficient audio drive to the LM386 audio output amplifier to drive an 8-ohm speaker.

You can increase the gain of the Desert Ratt (if needed) by increasing R13 to 2.0K or 2.2K. Likewise, you can reduce audio gain by making R13 smaller.

Better low frequency response can be obtained by bypassing R12 with larger cap (try C11 = 4.7μF) or making C12 > 1μF. It's that

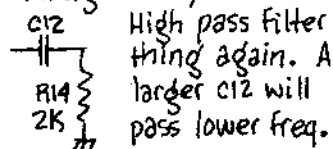

## ⑨ Q5 PHASE-SPLITTER

There's lot of RF floating around due to the Q2 regen stage - which gets into the LM386 and causes distorted audio and other problems. I added the phase splitter to drive the LM386 with DIFFERENTIAL SIGNALS, so the common-mode RF stuff would cancel out. It is an optional stage, and offers no gain since

$$A_v = \frac{R_c}{R_e} = \frac{R_{17}}{R_{18}} = \frac{4.3K}{4.3K} = 1$$

But by converting the single-ended audio to differential, you pick up 6dB of gain, as shown in FIG. N.

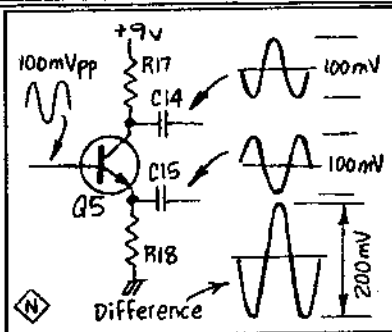

Each output (C14, C15) is 100mV, as is the input for no gain. But when added together by the LM386, the difference becomes 200mV for a volt. gain of 2 = 6dB.

Values for R17 and R18 is not critical, provided they are equal in the range of 1-5kΩ.

## ⑩ UI - THE LM386 AUDIO AMPLIFIER

The LM386 is an inexpensive audio amplifier I.C. widely available - even Radio Shack. Normally it is operated in the single-ended mode as shown in FIG. P.

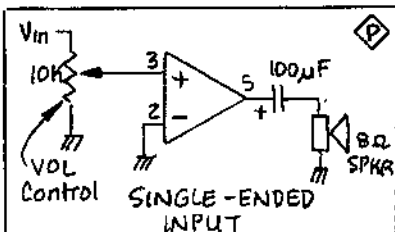

The LM386 has programmable gain. With no external capacitor, it has a voltage gain of 20, or 26dB. By adding an external gain cap between pins 1 and 8, (10µF typical) the gain is increased to 200, or 46dB. See FIG. Q.

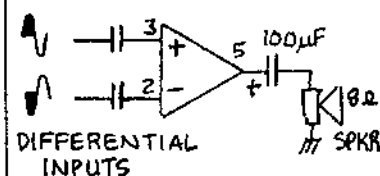

Good power supply bypassing is important by making a low-pass filter (R19-C19). C19 can be much larger than 10µF - to 220µF, to keep the DC volt. on pin 6 constant.

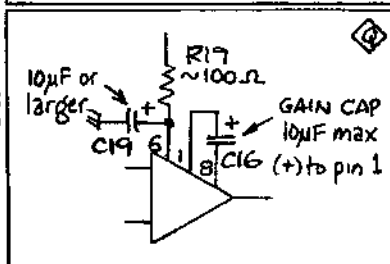

### INSIDE THE LM386

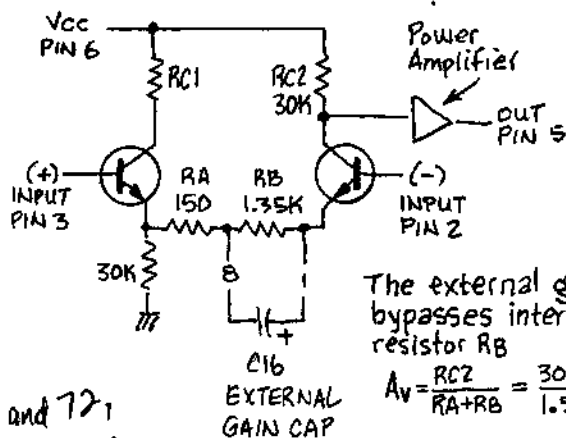

The external gain cap C16 bypasses internal gain resistor RB

$$A_v = \frac{RC2}{RA+RB} = \frac{30K}{1.5K} = 20$$

$$\text{bypass } R_B = \frac{30K}{150} = 200$$

GL and 72,  
Paul NASN

## The BLT, A Balanced Line Tuner

by Charlie Lofgren, W6JJZ and Doug Hendricks, K16DS

This tuner was designed by Charlie Lofgren, W6JJZ, who is renowned in the QRP World as a tuner expert. Charlie has built all of the tuners used by the Zuni Loop QRP Expeditionary Force for years, and they all swear by them.

The BLT is a balanced line tuner only, and will not work with coax feedlines unless modified as shown in the mods and improvement section. But it works great with open wire feeder, ladder line, zip cord, and ribbon cable. As long as you are using balanced line as a feedline, this tuner will work.

Charlie designed this tuner to work specifically with the polyvaricon variable capacitors available from Mouser. I asked him to design it at first because I wanted a simple tuner for a presentation that I was doing at the Ft. Smith QRP Group Forum, ArkieCon 2000. It turned out so well that everyone who saw it wanted one. Thus the NorCal W6JJZ BLT Kit was born. I would like to thank Charlie for his efforts on behalf of NorCal. This one is going to be a classic.

The design is for a classic Z match, using inductive coupling with L1, L2 and L3 wound on a single T106-2 toroid. L2 or L3 is switched in and out of the circuit by Switch 2, located on the back panel of the tuner. The "high" and "low" positions on the switch for the output links may need clarification. The positions are for "high" and "low" in terms of impedance, not frequency. For a given band and antenna, try the high Z link first, and use the low Z link only if a match can't be found with the high link. (Often either link will allow a match. In these instances, the high Z link pro-

duces better efficiency as a result of loading the tank circuit more heavily.)

The circuit also includes the famous N7VE LED SWR indicator circuit. Dan Tayloe invented this several years ago, and it has proven a great addition to the qrp fraternity. This allows us to have an indication of lowest SWR on the tuner (indicated by dimming or LED going out at minimum SWR).

The circuit also is an absorptive bridge, which means that your transmitter sees a 50 ohm load as you are tuning up, which will help to save your finals. This tuner is rated at 5 Watts. I doubt if the polyvaricon caps will take the 100 Watts of your big rig!!

The first step in building the rig is to build the custom case. The case is made out of .060 pcboard stock, and has been precut to size for you. All that you have to do is drill the holes for the front and rear panels, and then solder the kit together.

If you have tried to build a case out of pc board and had trouble keeping the sides square, you are not alone. But George Heron, of the NJ QRP Club has figured out the secret of building these cases and shares his secrets here.

The parts for the case have been mass produced. You need to check them to make sure that you will have a good fit. Start with the top and the bottom. The top should be 1/8" wider than the bottom. Check the two pieces to make sure that they are. If they are not the correct size, use a straight edge to mark a file line, and file the edge to the correct size. Be sure to do this check as it will affect how your case fits. Next, check the front and back panels, make sure that

they are the same width as the bottom, if not mark and file as before.

Locate the front and rear panels. You will use these as "guides" to help keep the sides of the top square. Use one of the side panels (B) and place it along side the top. It will go on the top of the panel as shown in Fig. 1. Next, take the front panel, and tack it in one spot on the underside of the top, using the side panel to make sure that the side panel fits flush with the edge of the top. See Fig. 1.

Use the guide to keep it square, and tack it on one end of the side panel. Now, go to the other end of the side panel and tack that end. Make sure that the side is flush with the top. Now, tack the bottom of the "guide" panel to the top edge of the side as shown in Fig. 1. This will keep the side square to the top as you solder. Don't use a lot of solder here, because you are going to have to unsolder this. Also, be sure that you solder on the side that will not show of the "guide" piece.

Once you have the guide ready to go, just fill in the seam with solder along the edge of the top and the side. I tilt mine at a 45 degree angle, and it works very well.

When you finish with the first side, do the other side just like you did the first. When you finish, unsolder the guide using solder wick, and you have the top finished, all nice and square. Now for the good news. You have just finished the hard part of the case. The bottom section is a piece of cake.

First, use the drilling templates to mark the holes as indicated and drill the front and back panels to the size indicated. Make sure that you are accurate on the capacitor holes, as you do not want to have the center shaft of the capacitor touching the

case. An easy way to mark and drill the holes is to cut out the front and back hole locating drawings and tape them over the front and rear panels. Then, using a 1/16" bit in a drill press, it is a simple matter of drilling through the paper at the X marks the spot locations of the holes. Then you can enlarge the holes to the proper sizes as indicated.

Now that you have the holes drilled we are ready to start the bottom case assembly. Take the bottom piece and one of the side rails. Line up the side rail with the ends flush and the sides flush. Tack solder it on one end. Get it as straight as you can, but don't worry about it, we will adjust it later. What we are concerned about is that the ends are flush. Now, place the front panel against the ends of the bottom and the side panel. Make sure that it is oriented correctly, lined up, and solder it on one end. Check your work. If everything is lined up, unsolder the side rail and make it fit straight, flush with the edge of the front panel. Now, solder the bottom of the side rail and the junction of the top side of the side rail and the front panel. Do the other side rail as you did the first. This will hold the front panel square, and now you may tilt it up to solder the seam as you did on the top.

When you finish the front panel, do the same with the back, making sure that you orient the panel correctly. The case is really quite easy to build and the neat thing about it is that you use the parts to self align it. Many thanks to George Heron, N2APB for his invaluable assistance with these instructions. In other words, George, thanks for the trade secret, grin.

We are ready to start building the tuner. The first step is to prepare 6

wires that are 4" long. Solder 4 wires to Switch 1 as shown in the wiring diagram on the schematic page along with the jumper. Mount Switch 1 in the front panel. Next, solder two wires to the middle connections of Switch 2. Mount Switch 2 in the back panel.

We are ready to wind the two toroids now. Start with the larger one, the T106-2. Cut off 30" of the heavy red enameled wire. Bend it in half, and clean off the insulation for 1/2" on either side of the center of the wire. Then, twist the wires together 3 times forming a tiny loop that will be the center tap of L1. Take the toroid, put the wire through the center of the toroid and hold the twisted loop against the edge. Wind the wire 8 times around the toroid, counting 1 turn each time the wire goes through the center of the toroid. Now, wind the other end of the wire 8 more times going in the opposite direction. When you finish, spread the turns evenly around the toroid, and bring the ends of the wire up to the side opposite the twisted loop, trim the wires about 3" long.

The coils for L2 and L3 are wound interspersed and in the same direction as L1. The wire for L2 is 24" long, and the wire for L3 is 12". When you finish winding L2, the toroid will have two wires sticking up on the outside of the toroid, and two coming up through the middle. When you finish with L3, you will have 3 wires on the outside, and 3 on the inside. Place the toroid in the case approximately where it will be and trim the wires to the lengths needed to attach L2 and L3 to Switch 1 and to attach L1 to C3. Clean off the insulation by burning it back for about 1/2" and then carefully scraping off the residue with a knife. Now you are ready to mount the big toroid. Place

it where it goes in the case, and solder the tap of L2 to the bottom of the case. Then solder L2 and L3 wires to Switch 2. We will solder the connections to C3 later.

Now lets wind the smaller toroid. You have two smaller diameter pieces of wire, one red and one green. Start with the red wire and wind 25 turns on the toroid. Count the turns on the inside of the toroid with each time the wire passes through the center of the toroid as one turn. Trim the wire to 1 inch leads, remove the insulation and tin the leads. Now, take the piece of green wire and wind 5 turns. Start the winding in the middle of the red wire and the toroid should look like the drawing below. Trim the ends of the green wire to 1", remove the insulation and tin the leads. Set the toroid aside for now.

Prepare the six 100 ohm 2 watt resistors by twisting the leads together to make 3 pairs of resistors. This will result in 3 - 50 ohm resistors.

Now we are ready to build the SWR absorptive bridge and LED indicator circuit.

Use the layout drawing as a guide and build the circuit Manhattan style. You will find several round pads provided in the kit. Use these as "tie points" as shown. They are glued down to the base of the case using super glue. One small drop per pad is plenty. Place the drop where you want the pad, then with tweezers or needle nose pliers place the pad on the glue. Press down and hold for 30 seconds. Tin the pad. When you have the pads in place, build the circuit. The ground symbol means that you solder the end of the component to the base of the case, which is ground. Make sure that you orient the diodes correctly. The LED has the short lead grounded to the case

front which holds it in place, or you may use a drop of super glue here, just be careful to not get it on the lens. The other lead of the LED connects to R4, the 1K resistor.

Now we will prepare C2 and C3. Put a jumper between the outside leads of each capacitor as shown. Then, make sure that the trimmer adjustment caps on the back are set at lowest capacitance, which means fully unmeshed. Now mount the two caps to the front panel. Make sure that the center conductor does not touch the case, or your tuner will not work right. Tighten the small screws snug, but be careful to not strip the threads. Run a jumper wire from the two tied together connectors on C2 to the two tied together connectors on C3. Connect the middle connector of C2 to SW1 as shown.

The caps do not have shafts for knobs, but we can fix that easily. In your kit of parts you will find two nylon spacers. Attach them to the center hole of the cap with the 2.5 x 16mm screws provided. You will want to put a drop of super glue between the spacer and the cap to keep it from spinning, or you could use a tiny lock washer here (not provided). Just be careful to not get any glue in the cap!! Now you have a shaft to attach the knobs to!! Thanks to Dave Gauding, NF0R who showed me that trick.

Connect the L1 wires as shown on the wiring diagram.

Finish wiring the connections for SW1 and SW2. Check the diagrams to make sure that you have connected

all the wires. That is all there is to it. Your tuner is now finished!!

To operate the tuner, connect a balanced feedline to J2 and J3. Run coax from the BNC to your rig. Place SW1 in the Tune Position. Place SW2 in the High impedance position. Press the key or put your rig in "tune" mode, and use the two tuning knobs on the front panel to get the LED to go out, or at least dim significantly. If you can't get a match on high impedance, change to low impedance with SW2. My tuner tunes a NorCal doublet made from ribbon cable and 20 feet up in the air on all bands from 10 - 40 meters. Your mileage may vary.

#### **Mods and Improvements:**

If you wish to use the tuner with unbalanced feedlines, i.e. coax or long wires, then you need to do the following mod. Mount a spdt toggle switch on the back panel and another chassis mount BNC. You will use the toggle switch to ground one side of the balance input connectors. To operate as a balanced tuner, switch to the unground position. To operate as an unbalanced tuner place the switch in the ground position. Simple mod. But if you are going to do it, I suggest that you do it before you build the tuner, as it is easier to do at that time. Radio Shack has a nice miniature SPDT switch and they also carry BNC chassis mount connectors.

Good luck, enjoy your tuner, and have fun on the air. Many thanks to Charlie Lofgren, W6JJZ for his invaluable assistance on this project. 72, Doug, K16DS

**BLT Tuner Kits are available from NorCal. The cost is \$25 plus \$4 S&H for US & Canada, \$6 Europe & Far East. The kit is complete with all parts, pboard case, and clear lexan cover. To order send a money order or check in US Dollars to: Doug Hendricks, 862 Frank Ave., Dos Palos, CA, 93620. Please make check to Doug Hendricks and NOT to NorCal. Please enclose a self addressed mailing label.**



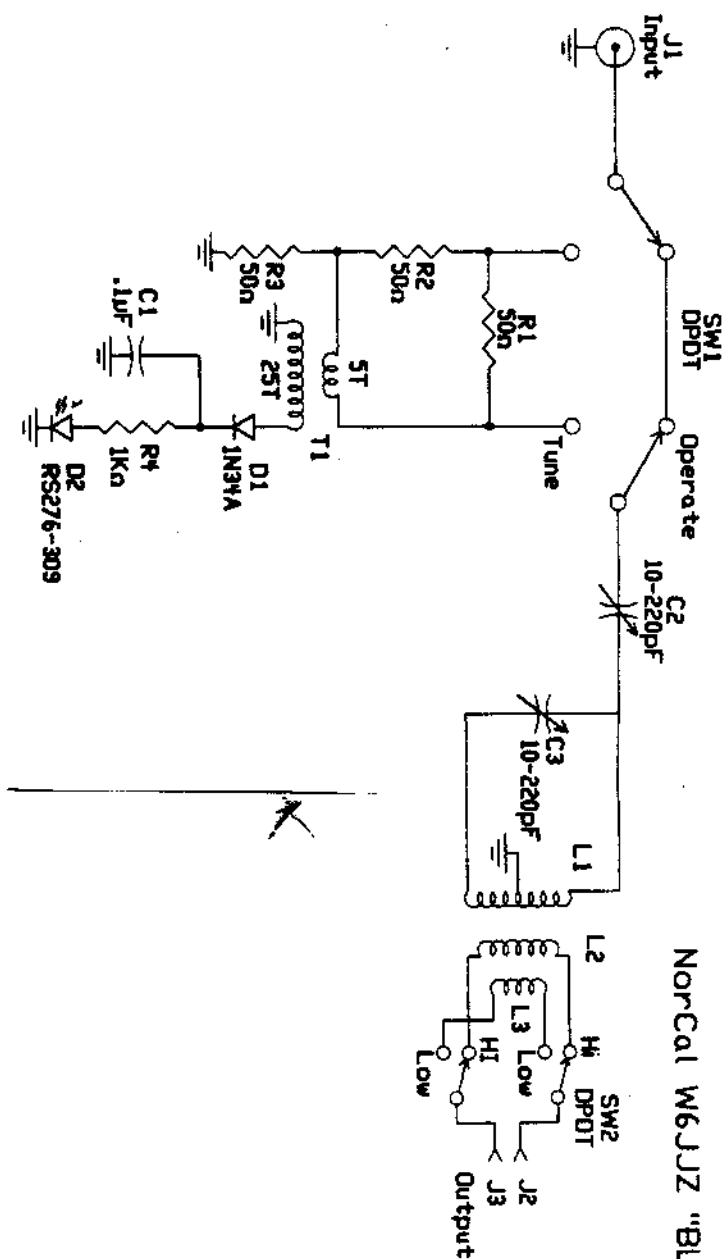

NorCal W6JUZ "BLT" Tuner

C1, C2 = 140/80 "Poly" caps with sections in parallel  
 Be Sure to set trimmers to 0.

L1 = 16T #22 Enameled Wire on T106-2 Toroid  
 Tapped at 8 Turns to ground

L2 = 12T #24 Enameled Wire centered around  
 ground tap on L1, and interwoven with turns of L1

L3 = 6T #24 Enameled Wire centered around ground tap  
 on L1, and interwoven with turns of L1 & L2.

T1 = 5T Primary, 25T Secondary on FT37-61

R1, R2, R3 = 2 - 100 ohm resistors in parallel.

Front Panel Hole Location

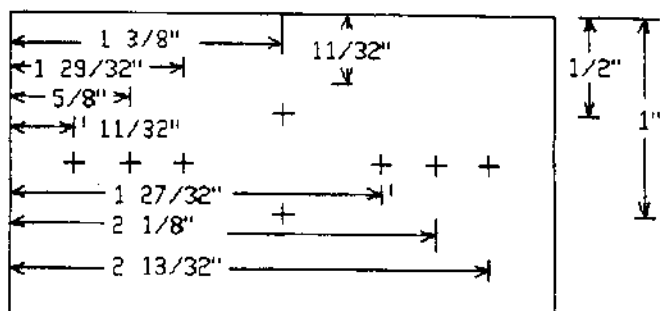

Front Panel 2 3/4" x 1 1/2"

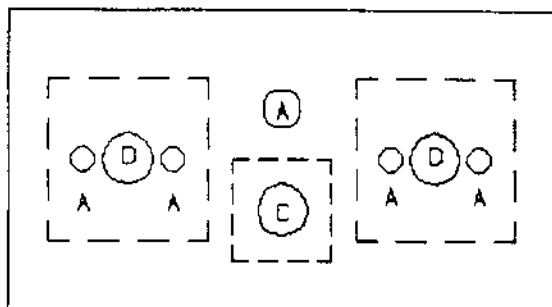

- A = 1/8"
- B = 3/16"
- C = 1/4"
- D = 9/32"
- E = 3/8"

### Back Panel Hole Location

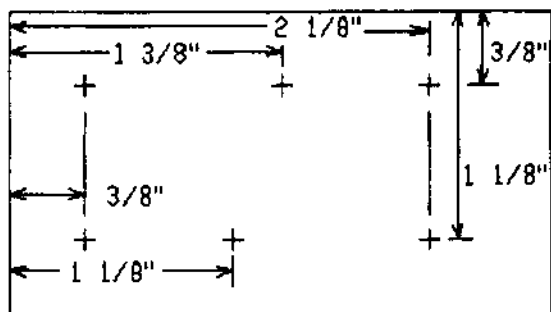

### Back Panel $2\ 3/4" \times 1\ 1/2"$

- A =  $1/8"$
- B =  $3/16"$
- C =  $1/4"$
- D =  $9/32"$
- E =  $3/8"$

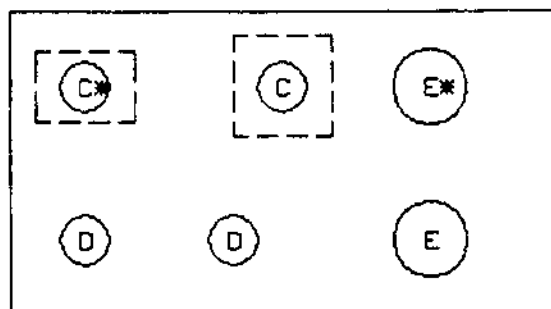

Note: C\* and E\* are optional

### Details of Switch Wiring

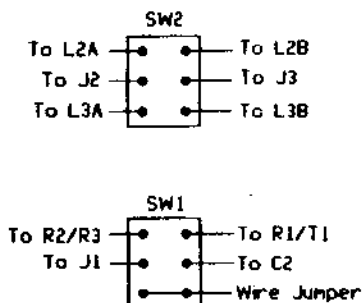

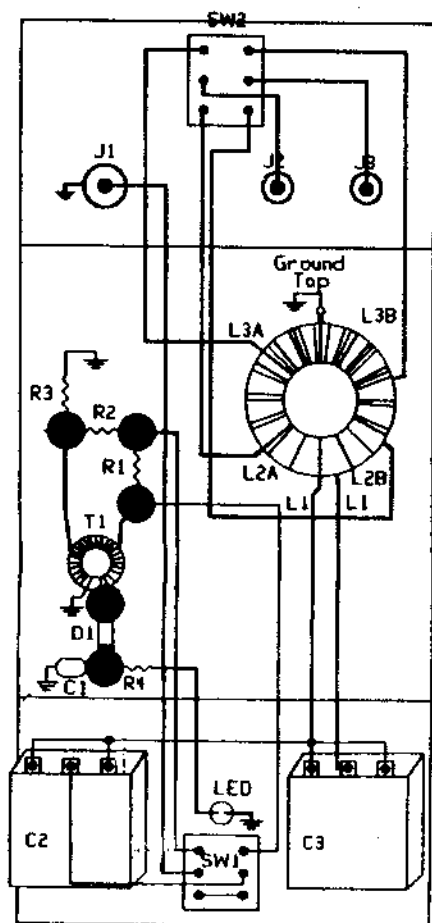

Wiring diagram and parts placement for the BLT tuner. Note that the front and rear panels are shown in a "folded" down position for illustration only.

# **Pacificon 2000**

**Friday, Saturday and Sunday**

**Oct. 20, 21, 22**

**Sheraton Hotel  
Concord, California**

**QRP Forum Speakers**

**Saturday**

**Tony Fishpool, G4WIF, Dartford, England**

**Graham Firth, G3MFJ, Leeds, England**

**George Heron, N2APB, Forest Hill, MD.**

**Mike Gipe, K1MG, Saratoga, CA.**

**Dave Gauding, NF0R, St. Louis, MO.**

**Dan Tayloe, N7VE, Phoenix, AZ.**

**Vern Wright, W6MMA, Placerville, CA**

**QRPp Columnists:**

**Richard Fisher**

**Paul Harden**

**Will be on hand to meet and visit with you all weekend. Give your suggestions to them for things you would like to see in their columns.**

**4 Building Contests Saturday Night**

**SMK-1 Operating Event Friday Night**

**No Host Dinner at Fuddruckers Friday Night**

**Red Hot Radio NC20, Red Hot NC20 and Red Hot 40**

**Group Picture Saturday Afternoon (all who bring radios for the photo will receive a free t-shirt from**

**Red Hot Radio**

**QRP Open House Friday and Saturday Night**

**NO Additional charge for any QRP Functions**

**Sponsored by NorCal QRP Club**

We have another exciting program planned for you this year. Friday night, we will have a no host dinner starting at 6:30 at Fuddruckers, a hamburger emporium near the hotel. We will meet in the lobby at 6:00 to arrange rides.

Then we will return to the hotel where we will have a QRP Open House Hospitality room starting at 7:30 PM. The feature event on Friday night will be an SMK-1 QSO party. This fun event will start at 8 PM and run for one hour. At the end of the hour, we will exchange qsl cards for the contacts that you have made. Since this is a qrp event, we want qrp qsl cards. So guys, get one of the qsl maker programs, and make some business card sized qsl cards!! The required info will be Stations Call, RST, Name, and first year licensed, date, time & frequency.

You must run an SMK-1 rig to participate, and you may use any antenna that you can fit into the room. (Note, you may not attach the antenna to the walls with any type of tape, nails, staples, old gum, hot glue gun, etc.). The idea will be to work as many stations as you can with your SMK-1. You may modify your SMK, you may bring outboard filters, but your rig must be an SMK. After the QSO party, the operator with the most qso's will be awarded a prize.

The rest of the evening will be spent visiting.

After the final qrp session on

Saturday, Dave Fifield, of Red Hot Radio is hosting a Kodak moment for all NorCal 20, Red Hot Radio NC20, and Red Hot 40 owners. If you bring your radio for the group picture, Dave will present you with a free Red Hot Radio T-Shirt as a special token of his appreciation for your support of Red Hot Radio and QRP.

Saturday night will feature the famous NorCal Building Contest, and this year we will feature the SMK-1 "beauty contest". We will judge your entry for quality of construction and packaging. There will be two divisions: NJQRP Club SMK-1 Case Kit and Original Case Also, JayBob Bromley and the Ft. Smith QRP group will sponsor the Ft. Smith QRP Group P-TICK division. Bring your P-TICK, and we will decide who built the best version of this fabulous \$10 kit.

Finally, we will have the Manhattan construction division. This will be for any project built using Manhattan Style construction and not entered into a contest previously.

Pacificon will be fun this year. As always, no additional charges for any of the QRP activities, other than the admission to the hamfest. This is NorCal's way of reinvesting in QRP. We want to encourage QRP and to have fun.

Hope to see you in Pacificon. I'll be the guy with the thick glasses, no hair, and a big grin on my face having fun.

72,  
Doug

## QRP Operating News

By Richard Fisher, K16SN  
1940 Wetherly Way  
Riverside, CA 92506  
[K16SN@yahoo.com](mailto:K16SN@yahoo.com)

### New and Noteworthy

**Bob Reisenweber, W3BBO**, writes from Erie, PA that he was very glad to see the new QRPp Operating News column. After receiving his Winter edition, he "wanted to drop a note and wish (the new column) well.

"I was very fortunate in my introduction to QRP. I was working in New Jersey and living in a basement apartment.

"The XYL and family were a seven hour drive away, so I only made it home every four to six weeks, with longer periods between trips during the winter.

"So what can a guy do?

"You work all day, come back to the apartment in the evening and turn on the 'boob tube.'

"That gets old quick, so I thought building a QRP rig might be fun, plus it would occupy some of my evenings.

"Thank God for computers and the Internet!

"Here I found all sorts of web sites that pertained to QRP, like operating, kit building and clubs!

"Off went my order for (an Oak Hills Research) OHR-100A to cover 20 meters.

"Then the biggest step of all, I joined the New Jersey QRP Club.

"Wow! What a great bunch of people.

"All were eager to share ideas, stories and help.

"Now that I'm back home and safely retired, I miss most those gatherings we had. However, I stay in touch thanks to the NJ-QRP web site and trips to Atlanticon.

"Milliwatting can be a blast! The NJ-QRP club sent a SNAP kit to each person attending Atlanticon 2000.

"This kit was a simple crystal controlled, single 2N2222A transistor oscillator for 80 meters.

"The purpose was to build the rig using 'Manhattan-style' construction and be judged in the building contest at Atlanticon.

"Needless to say, we just didn't build the unit and wait for Atlanticon - several of us decided to put it on the air!

"My best contact was with a VA3 station just outside of Toronto.

"My SNAP was running slightly under 20 milliwatts and I obtained the QRP ARCI 1,000 Mile per Watt award for this contact.

"The award gives the mileage as 5,650 miles per watt.

"Certainly not a world record, but it still amazes me that milliwatting works at all, and my hat is off to guys like (Jim Hale) KJ5TF, N4ROA and the many other milliwatters who experience this thrill daily!

"Regarding QRP contesting, I'm not sure which types of contesting I really like best - QRP contests or the major tests.

"On the QRP side, there is the monthly Adventure Radio Society's Spartan Sprint, the QRP ARCI QSO Parties, plus really fun events like QRP To The Field (QRPTTF) and the Zombie Shuffle.

"The major contests for me include the Pennsylvania QSO Party, ARRL November Sweepstakes,

ARRL DX and the CQ WPX tests. All are fun!

"The QRP tests are more laid back and most stations will QRS and even ragchew, however the major tests are more demanding and everyone is going for 'rate' and 'score!'"

"In either case, operating in these events will improve your CW skills and operating technique.

"So turn the rig on and jump in. You may find you like contesting!"

"As for QRP ragchewing, I guess I'm a DX'er at heart.

"When that rare DXpedition comes on the air, I'm in there trying my best to make the QSO.

"Unfortunately, now days the operating practices have seemed to slip considerably.

"The DX station frequency gets QRM'd.

"Frequency police then get all worked up, and chaos ensues. That's when I take a deep breath, switch bands and look for a nice ragchew! I've had some great QSOs on 40, 80 and 160 meters.

"Amazing what a nice QSO can do to relieve the frustrations caused by chasing DX.

"A couple of real 'characters' that I'd like to read about include that guy Nils, W8IJN, and the displaced cajun, Joel, KE1LA! Plus many more like that don't immediately come to mind. I'm sure you have a warehouse full!"

"On the swap meet scene, this past Fall I attended the Buffalo hamfest and ran into Howard, K2UD.

"Howard was wearing his QRP namebadge and carrying a knapsack.

"After I introduced myself, Howard opened his bag and brought out his homebuilt 2N2/40 rig. Right there in the middle of an aisle, we stooped down and Howard removed the transceiver cover and showed me

his Manhattan constructed unit.

"What beautiful construction, a work of art! A week or two later, I worked Howard on 40 CW and the little rig sounded as sweet as it looked!"

"Often I wonder what all the hip-toting HT people walking by thought." **QRP adventures on the AT**

**Steven Weber, KD1JV**, writes from Gorham, NH: "Boy, I'm a little tired and sore.

"When I got up this morning, the weather looked a little iffy, but by the time I got to the trail head at noon, the clouds were breaking up and some blue sky could be seen, so went ahead with the hike.

"It's been some time since I've last visited the Gentian Pond Shelter along the Appalachian Trail as it passes through New Hampshire.

"I had remembered it wasn't a difficult hike, but had forgotten it was fairly long, about 5-6 miles, with the last 3/4 mile a pretty stiff climb, which is generally the case around here.

"Over all, the climb is about 3,000 ft. Took 2 1/2 hrs to get to the shelter, steady walking, no significant breaks. If you stop, all the bugs catch up with you.

"Shortly after arriving and setting up, an Appalachian Trail through hiker passed by on his way to Maine, so had to chat with him a while and explain the little radio and all.

"Finally made my first contact at 19:11 UTC with W1PID, then N1MGA, N1EI, a long chat with N3CU, then W3PNL and finally W1II.

"So, only six contacts, all on 40 meters. Twenty meters seemed dead. Amazing how quiet the radio is that far into the woods.

"By 20:00 UTC, 4 PM EDT, the clouds were getting thick, dark and lower, so decided it was best to pack up and run down the trail.



"Got back to the car just minutes before it started to rain. Whew. Fed quite a few 'sketers on the way down and a number of black flies on the way up.

"All in all, a good day's work out, though not too productive contact wise. Will have to do it again, maybe make it an overnight next time.

"Just wish it would stop raining every darn day.

#### **In the hunt with the SMK-1**

**Bob Cromwell, KC9RG**, writes that he's "been on the road with work, and have only recently gotten my SMK-1 on the air.

"I made the ~850mW mod, getting the 12V supply for the final with a 1 mH choke - hey, it was handy - connected to a through hole near a transistor on the pot side of the transformer. I don't have the board with me here in the lab to quote the exact location.

"With an antenna consisting of a quarter-wave of wire thrown off my second floor apartment balcony and draped head-high through a couple of trees, I managed to work WA3BKD/MM on a houseboat on the Ohio River north of Wheeling, WV.

"As I'm in West Lafayette, IN, I'm pretty happy with that!

"The next step is to test my new antenna, which is a discrete connection to the building's rain gutter.

"First HF QSO from home in, wow, probably 10 years! Have been on HF at the Purdue Radio Club (W9YB) but not from a series of apartments.

"The SMK-1 provides fun and a sense of accomplishment — what more do I need? I know, I know, the next SM kit!"

#### **Building the NW8020**

**David Bixler W0CH / VK2IQX**, writes from Seneca, MO that he "just

wanted to share with the group about my latest project, the building of a Emtech NW8020 for 20 meters.

"This particular kit has been unbuilt since 1996, and was probably kitted by the late Roy Gregson, W6EMT.

"I started the board stuffing on a Tuesday evening and by Thursday I had a working receiver.

"The NW80XX case arrived from Emtech also on Thursday.

"I finished the transmitter parts placement on Saturday and by Sunday I was putting the board into the bottom half of the case.

"Sunday night, I fired it up on a real antenna for the first time and found the band active with signals.

"Tried calling N4ROA, who was CQ'ing for a QRP contest, but had no luck.

"I then went down the band and heard a strong F9 (France) calling CQ.

"I gave him a call, and he came right back. Got a 559 report from Toulouse, France for the first QSO. Not too bad for 4 watts to a vertical wire.

"Second QSO honors went to Dave Gauding, NF0R, up in St. Louis who was working the contest with a mighty 250 milliwatts.

"I got a few details to finish on the rig (like putting the knobs on) before putting the cover on. But it looks like this is going to be a nice little rig."

#### **Flight with a Bumblebee**

**Bruce Grubbs, N7CEE**, writes from Flagstaff, AZ, that "a non-ham friend proposed a last minute backpack trip in California's Sierra Nevada, so I ended up operating my Wilderness Radio Sierra from its namesake range for the first time.

"The Adventure Radio Society's 'Flight of the Bumblebees' fell on the

fourth day of the six day trip, and the operating site was spectacular - near Paris Lake in the Mount Humphreys region, at 11,200 feet (DM07pg).

"I used a ZM-2 and 66 feet of wire, end fed, and a 33 foot counterpoise. The antenna was up about 20 feet on the timberline whitebark pines.

"I worked 20 stations - far below last year's total - as conditions on 20 and 15 were rough.

"Signals were right in the noise. Forty meters was strong but everyone worked was 'local,' of course.

"My non-ham friend was very supportive of the whole operation - in fact Doug made me take the Sierra instead of the DSW40, and took numerous pictures of the operation. We had a great time on the trip."

#### Logging QRP DX

**Steve Yates, AA5TB**, writes from Forth Worth, TX, that recently he "worked ZF2SC on Cayman Island on 30 meters.

"No big deal I know and I've worked Cayman Island before, but wait. . .

"I was his first QSO in a pile-up and I was just using my PRC-38S (a.k.a. 38 Special) at 3.5 watts, solar charged battery, and my 3 foot diameter loop up 2 feet off of the ground underneath a bushy pine tree.

"The neat part was after my first call to him I heard many stations calling him on top of me and when the dust settled he came back to me (I did not sign / QRP).

"Then he repeated my rig and antenna information for all the QRO guys waiting in line to hear.

"Just one of the joys of QRP I guess - the ability to get most enjoyment out of every QSO.

"I know, I'm bragging, but that is part of what makes QRP fun.

"I certainly can't brag about a

new amp with the new 4CX1600s in it!

"Those of you with antenna restrictions, build a loop and put it 'under the house,' on the balcony, in the attic, or in the bath tub and make some contacts (just kidding about 'under the house.')

#### . . . more AT QRP

**Ron Polityka, WB3AAL**, writes that he headed off for an Appalachian Trail radio adventure recently, arriving at 8 a.m., "and I hiked in about 3/4 of a mile.

"I found a nice big old tree that I shot a line into with my sling shot.

"Tall trees, 40 foot or better, are hard to find on the AT on top of a mountain.

"I learned that fishing line does not travel over wet bark too easily.

"I got my Killer Vertical up and it worked great.

"I called CQ on 40 meters starting at 9:30 a.m. I called for 45 minutes on 7.038 MHz and I had no takers.

"So I went to 30 meters and I had some QSOs with stations on the East Coast. Overall I made 14 contact between 40, 30 and 15 meters.

"I also made two SSB contacts with K1QM in Concord, MA and N2SEX the light house in Cap May, NJ.

"I had a F6 station call me on 15 meter CW, I went back to him but I had no reply.

"Three deer came up behind me about 300 feet away. I moved and scared them, boy did I jump!

"I saw a flock of starling birds flying through the woods about 2 to 8 feet high off the ground. This flock went on for about 4 minutes.

"About 5 minutes later they cut across the back side and turned toward me. Time for the hat!

"I turned on the speaker and they flew around me. It looked like the Hitchcock movie 'The Birds.'

"Thanks to all the stations that replied to my CQ. Sorry I did not pick out the calls on the weak stations.

"Don't worry, I plan to go back soon to the same site."

#### **PY2 on 10 meters**

**Ken Hoglund, KG4FGC**, writes from Winston-Salem, NC that "the sun was setting, thunder rumbled to the west, and I found myself with a few odd moments with nothing to do before having to shuttle the kids to yet another location.

"Wasn't the Green Bank station starting Friday afternoon? Warmed up the rig and tuned to 28.350 - no luck. The 10-meter band was full of

pops, hisses, and rolling signals.

"But wait - sounds like a PY2 calling 'CQ DX.' Why not try?

"So with all the mighty 8 watts the rig was tuned down to, small explosions popping in my ears, I replied with my call. 'QRZed?,' came back.

"I repeated my call, slowly, clearly, and hoping against hope.

"Yup - made the QSO long enough to exchange call signs and signal reports.

"The moral of the band: Sunspots may be down, flux may be off, a storm may be brewing, there may only be a few minutes left to the band, but QRP rules!

"Now how do I go about getting one of those SSB wallpapers?"

### **QRPP Subscriptions**

QRPP is printed 4 times per year with Spring, Summer, Fall and Winter issues. The cost of subscriptions is as follows: US and Canadian addresses: \$15 per year, issues sent first class mail. All DX subscriptions are \$20 per year, issues sent via air mail. To subscribe send your check or money order made out to Jim Cates, NOT NorCal to: Jim Cates, 3241 Eastwood Rd., Sacramento, CA 95821. US Funds only. Subscriptions will start with the first available issue and will not be taken for more than 2 years. Membership in NorCal is free. The subscription fee is only for the journal, QRPP. Note that all articles in QRPP are copyrighted and may not be reprinted in any form without permission of the author. Permission is granted for non-profit club publications of a non-commercial nature to reprint articles as long as the author and QRPP are given proper credit. The articles have not been tested and no guarantee of success is implied. If you build circuits from QRPP, you should use safe practices and know that you assume all risks.

**Back Issues QRPP: 1993 - \$10, 1994, 95, 96, 97- \$15 per issue, 1998, 99 - \$20 per issue. Shipping & Handling: US: \$4 for 1 - 3 issues. \$5 for 4 - 7 issues. Canada: \$4 for 1 issue \$5 for 2 - 3 issues \$7 for 4 - 7 issues. DX Europe &**

**South America: \$5 for 1 issue \$7 for 2 - 3 issues \$10 for 4 - 7 issues DX Pacific Rim, Australia & New Zealand: \$5 per issue ordered \$10 for 2 issues \$15 for 3 issues \$20 for 4 issues, etc.**

**QRPP, Journal of the NorCal QRP Club  
862 Frank Ave.  
Dos Palos, CA 93620**

**First Class Mail**

**First Class Mail  
U.S. Postage  
Paid  
Mailed from Zip Code  
93620  
Permit #72**

Volume VIII No. 3

FALL 2000

# QRPP

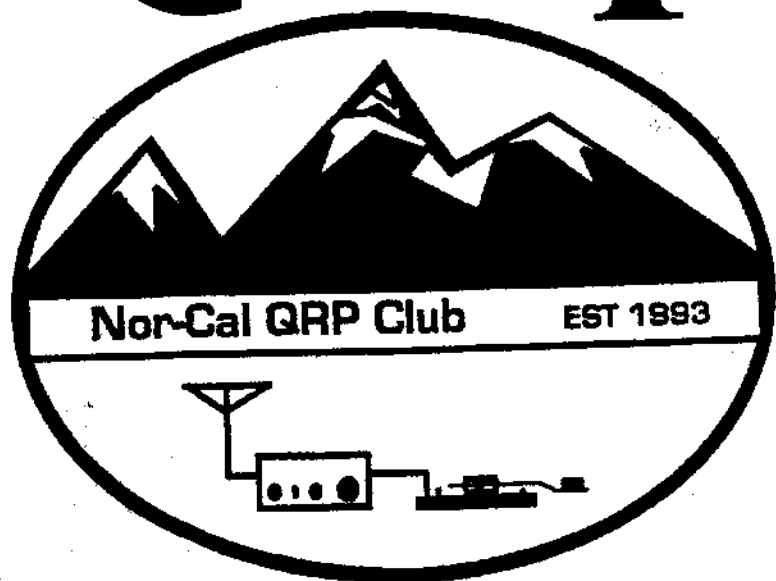

# Fall 2000

Journal of the Northern California QRP Club

## Table of Contents

<b>From the Editor</b> .....	2
Doug Hendricks, KI6DS	
<b>Modifications for MFJ QRP Cub Transceivers</b> .....	3
Larry East, W1HUE	
<b>QRP Operating News</b> .....	14
Richard Fisher, KI6SN	
<b>Iowa QRP 10</b> .....	19
Mike Fitzgibbon, N0MF, Illustrated by Paul Harden, NA5N	
<b>A Mosfet QRP Gallon</b> .....	39
Wayne McFee, NB6M	
<b>Portable, No Solder, No Tuner, Resonant 20 Meter Dipole</b> ....	44
Rich Wadsworth, KF6QKI	
<b>Building the St. Louis Coil</b> .....	47
Andy Becker, W0NVM, Dave Gauding NF0R Illustrated by Paul Harden, NA5N	
<b>Spring QueSo Party</b> .....	53
Bob Tellefsen, N6WG	
<b>An Integrated &amp; Portable PSK31 Station for 80/20 Meters ... Without Using a PC</b> .....	54
George Heron, N2APB	

### From the Editor

by Doug Hendricks, KI6DS  
ki6ds@dospalos.org

This is an exciting issue for me. With it, we are back on schedule for delivering QRPP. Thank you for your patience and understanding.

But the real reason is the quality of the articles. I would like to point out 4 of them. Larry East's Cub Mods article, Mike Fitzgibbon's Iowa QRP 10, Building the St. Louis Coil by Andy Becker, Dave Gauding and Paul Harden, and George Heron's PSK31 Station. These four articles are as good as we have ever had in QRPP. All of the credit must go to the authors and Paul Harden for his illustrations.

Speaking of Paul Harden, I

would like to publicly thank and recognize Paul for his outstanding illustrations both in this and past issues of QRPP. His work is to be treasured. Without his illustrations the St. Louis Coil and Iowa QRP 10 would be difficult to build at best. With them, they are easily accomplished. That says it all in my opinion. Thank you Paul.

One quick correction. Joe Everhart deserves the credit for thinking of the idea of the NJ QRP Club kitting the cases for the SMK-1 Kits. I had attributed that idea to George Heron in the last issue.

See you in the winter issue to be mailed the first week of January 2001. 72, Doug, KI6DS

## Modifications for MFJ QRP-Cub Transceivers

Larry East, W1HUE

Idaho Falls, ID

email: w1hue@arrl.net

*Editor's note: Larry's Cub mods originally appeared in the July and October 2000 issues of the ARCI QRP Quarterly. Since many of our readers don't receive the QRP Quarterly, I asked him for permission to reprint them in QRPP.*

### Introduction

The MFJ QRP-Cub series of single-band transceiver kits are fun little rigs to build. Most of the components are "surface mount" type and already installed. The remaining "through hole" components can be installed very quickly – and there are only two toroids to wind! Output power is on the order of 1 to 3 watts, depending on the band model. The design is quite basic and there are no "frills" such as RIT, frequency enunciator or built-in keyer. AGC (audio derived) is included, however.

I purchased a 15M kit mostly out of curiosity; considering the assortment of QRP rigs that I have including a recently completed Elecraft K2, I really don't need another radio (at least according to my XYL...)! As soon as I had it up and running, I found a few things that needed "improving". In particular, I found that the receiver recovery time was too long for my tastes. The tuning range was about 62 kHz, and I found that tuning with a single turn pot was very touchy. The "fixes" for these and a few other items that I imple-

mented in my Cub are described in this note.

### Tuning Linearization

As is common with varactor tuned VFOs, the Cub tuning is not very linear; frequency spacing (i.e., kHz/degree of tuning pot rotation) is quite a bit finer at the low end of the VFO tuning range than it is at the high end. The tuning linearity can be greatly improved by simply placing an appropriately sized resistor from the wiper of the

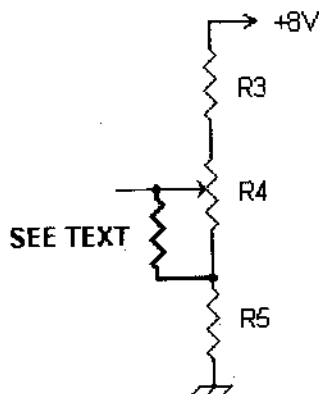

**Fig. 1 Resistor added to linearize tuning.**

tuning pot (R4) to the "cold end" of the pot (the end that connects to R5). This connection is shown in Fig. 1. The "appropriate size" depends on the particular band model that you have, but a good starting point is 4.7K. There are extra holes for the pot connections, so it's very easy to solder a

resistor to these holes on the bottom of the board. Probably the best approach is to tack-solder in a 10K pot, adjust it until you get approximately the same frequency spread on the first and second half of the rotation of R4, measure the pot value, and replace it with a resistor that comes closest to the pot value.

The shunt resistor will reduce the total tuning range slightly, perhaps 10 kHz or so for a resistor in the 3-5K range and more for a smaller resistor. (There will be less effect on the 30M model since it has a smaller initial tuning range.) The tuning range may be further reduced, if desired, by paralleling a resistor across all of R4. As noted above, my 15M CUB had a "stock" tuning range of 62kHz, which caused the tuning to be much too sensitive for my liking. By paralleling R4 with a 10K resistor and placing a 4.2K resistor from the wiper to the "cold" end, I obtained a 41kHz tuning range; 22 kHz are covered by the first half of the pot rotation and 19 kHz by the second half.

### **"True QSK" and Related Changes**

I made changes to the keying circuit to reduce receiver recovery time and improve the transmitter keying envelope. I also added a pot to adjust the sidetone level. These changes are interrelated and should be performed together.

No circuit board traces need to be cut, but one surface mounted

resistor must be removed. Only six additional parts are required:

1. 2N7000 FET (Mouser Part No. 625-2N7000)
2. 10 $\mu$ F 10V tantalum capacitor (Mouser Part No. 74-199D10V10)
3. 0.22 $\mu$ F small ceramic capacitor (Mouser Part No. 581-UEZ224K2)
4. 2K 1/4-in. (7mm) square potentiometer (Mouser Part No. 72-T70YU-2K)
5. 10K 1/4 W resistor
6. 2.2K 1/4W or 1/8W resistor (1/8W preferred)

It is not absolutely necessary to remove the board from the case, but it is probably more convenient to do so. A good magnifying lamp and/or "cheater glasses" will be very helpful; but if you are like me, you needed those to build the kit in the first place!

Start by removing R30. This is a 4.7K SMT resistor located near the right-rear edge of the PC board (near C34). You can take the brute-force approach, break the resistor in two with a pair of small cutters or diagonal pliers, and then remove the pieces from the pads with desoldering wick. Or, with a little effort, fine desoldering wick (0.020 - 0.030 in.) and a small prying tool (like a Dentist's pick), you can remove the resistor in one piece. First, remove as much solder from both pads as possible using desoldering wick. Then gently pry up on the resistor as you heat one pad and then the other. The resistor should pop off in one piece.



Next prepare and mount the 2K trim-pot; this will be the sidetone level control. Prepare the pot as follows: Looking at it from the rear, bend the left-hand lead over to the center lead, wrap it around the center lead and solder it. Trim any excess wire from the left-hand lead (*not* the center lead; you need it full length.) If the style of pot that you have has the three leads in a straight line, then the up/down orientation of the pot is not important. If the center lead is closest to one edge, orient the pot with the center lead nearest the bottom edge before making the above connection from the left-hand lead.

Now comes the somewhat tricky part: mounting the pot on the board. If you look just behind and between L1 and L2, you will see a plated-through hole in the board just behind C13 and between Q1 and C31. This connects to the ground plane on the bottom of the board. You want the center lead of the pot to go through this hole, with the pot sitting on top of C19 and C31. Be very careful not to short anything! Once the pot is properly positioned, solder the center lead in the ground feed-through. The pot can be kept in place by applying a little bee's wax to top edge of the pot nearest Y1, then use your soldering iron to melt the wax to secure the pot to Y1. You can also use hot glue (or some other adhesive), but bee's wax is very easy to remove without damaging anything if the need

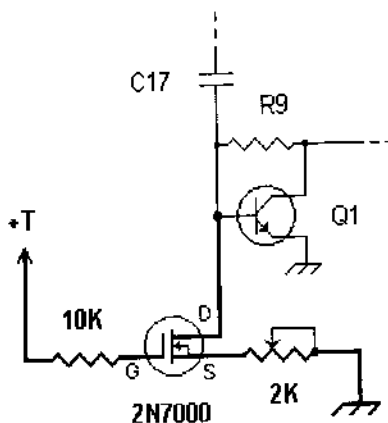

**Fig. 2. Components added for adjustable sidetone.**

should ever arise.

Next comes the 2N7000 FET. This is used to reduce the transmitter feed-through in the receiver by shunting the signal on the base of Q1 to ground. The amount of feed-through, and hence the sidetone level, is controlled by the 2K pot. When you are finished, the circuit will be as shown in **Fig 2** (the three added components are shown in **bold**).

Prepare the 2N7000 as follows: With the flat side of the transistor facing you and the leads pointed down, bend the left-hand lead up beside the transistor body. Bend the center lead up in front (the flat side) of the transistor. You now need to carefully solder the remaining lead (the right-hand one, which is the drain lead) to the front pad of R9 (the pad that connects to C17 and Q1). Shape the lead so that a short section will just fit over the solder pad of R9. The

bottom of the transistor should be about 3/16-in. above the board. The left-hand lead (the source lead) will be attached to the free lead of the 2K pot. After you have the two outside leads of the FET properly trimmed and bent into position, solder the drain lead to the front pad of R9 and the source lead to the lead from the pot. The gate (center) lead will be sticking up in front of the FET. **Note:** use a small soldering iron tip and relatively high temperature (750-800 degrees F) when soldering to the R9 pad and be quick! Hold the wire from the FET on the pad and touch the iron to the lead only long enough for solder to flow from the pad to the wire. After you have secured the FET in place by soldering the other lead to the pot, you can use a little solder if necessary to touch up the connection to the pad. Again, leave the iron on the pad only long enough to get the solder to flow. If you get too much solder on the pad, remove the excess using desoldering wick.

Next, locate the two feed-through holes between R19 and C27. The hole nearest R19 connects the "+T" line from the top to the bottom of the board; this is the one that you want. The 10K resistor connects between this hole and the gate (center lead) of the 2N7000. Bend one lead of the resistor at a right angle about 1/4-in. from the resistor body. Feed the bent end of the lead into the hole and trim the other lead so that it can be soldered to the gate lead

of the FET. The resistor should be positioned about 3/16-in. above and parallel to the board. (If you did not remove the board from the case, trim the bent resistor lead so that it will not extend below the board and short to the case. Otherwise, you can trim the lead after it is soldered.) Solder the resistor in place and trim any lead excess.

Now solder the 2.2K resistor between the front of R28 and R29 (immediately to the left of C27); see **Fig. 3**. The pads to which you will solder the resistor are the ones that connect to Q8. The resistor should be positioned on top of R28 and R29 with the leads bent to touch the two solder pads. A 1/8W resistor works best for this, but a 1/4W one can also be used. Again, be careful not to heat the pads too long or be sloppy with solder.

When you have the 2.2K resistor in place and the leads trimmed, solder the 0.22 $\mu$ F capacitor between the front pad of R29 (the same one to which the 2.2K resistor is attached) and the lead of the 10K resistor that passes through the PC board. The 2.2K resistor and 0.22 $\mu$ F cap are used to shape the rise and fall time of the CW keying waveform. Without these components, the CW envelope rise-time is very fast (about 0.1ms) resulting in minor but noticeable key-clicks. With these added components, the CW envelope rise and fall times will be about 2ms yielding very nice sounding keying.

Now all that is left to do is solder

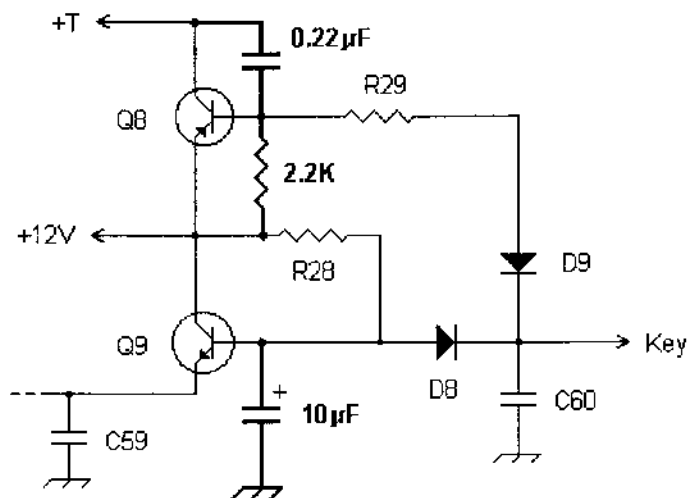

**Fig. 3. Modified T/R keying circuit. Added components are shown in Bold.**

the positive lead of the 10µF cap from the pad of D8 that connects to Q9 and R28 and the negative lead to ground. For the ground connection, use the feed-through hole between D5 and C60. The new Q8-Q9 switching circuit will be as shown in Fig. 3 (added components are shown in bold).

The 10µF cap ensures that the T/R switch (comprised of D4-D7) remains off a few milliseconds after transmitter output decays to zero so that no "thumps" or "clicks" will be heard in the sidetone. However, the receiver will still recover very quickly allowing full QSK operation.

The long recovery time of the receiver in its stock form was due to the AGC being blocked during transmit by a voltage applied to it

through R30. However, if you just remove R30, the sidetone will be extremely loud and will still activate the AGC. The FET shunt from the base of Q1 to ground eliminates this problem.

Carefully check your work for solder splashes, connection errors, etc. When you are satisfied that all is well, set the 2K pot to the middle of its range, connect the rig to a power source, key, dummy load and headphones. Apply power and key the rig; the sidetone should not have any "clicks" or "thumps" and the receiver should recover almost instantaneously on key-up. If not, then it's time to retrace your steps! If all is well, set the desired sidetone level with the audio pot set for a comfortable level for re-

ceiving and enjoy true QSK operation!

After this mod was published in the July 2000 issue of the *ARCI QRP Quarterly*, the designer of the QRP Cub, Rick Littlefield, K1BQT, expressed concern that the extra capacitance associated with the 2N7000 added from the base of Q1 to ground might affect the receiver sensitivity. Subsequent measurements have shown that any degradation is less than 0.5dB. However, Rick came up with his own QSK mod that is somewhat more straightforward than mine and uses fewer parts. Rick's mod is published in the October 2000 issue of the *ARCI QRP Quarterly* (page 17) and on the ARCI web site ([www.qrparce.org](http://www.qrparce.org)). If you use Rick's QSK mod, you should still install the 0.22 $\mu$ F capacitor and 2.2K resistor shown in **Fig. 3** to improve the keying envelope. However, the 10 $\mu$ F capacitor from the base of Q8 to ground (shown in **Fig. 3**) will not be required, nor the changes shown in **Fig. 2** unless you want to be able to adjust the sidetone level.

### VFO Warm-up Drift

Some Cub owners have noted significant warm-up frequency drift, whereas others see very little drift. Such variations are to be expected due to the normal production tolerances of the parts used in the VFO.

The major sources of possible drift in the Cub VFO besides the inductor and capacitors used in the cir-

cuit are the "tuning diode" (D2, an MV2104) and the SA602 mixer (U2) which is also used as the oscillator. Slug tuned inductors (and inductors wound on powdered iron toroids) usually have a positive temperature coefficient, causing the oscillator frequency to decrease with temperature. Most capacitors have a negative temperature coefficient, so the proper choice of capacitor size(s) and type(s) will almost exactly compensate the temperature drift of the inductor; this is the reason that a combination of polystyrene and ceramic caps are used in the Cub VFO circuit. The capacitance of the tuning diode is a small part of the total VFO circuit capacitance, hence its contribution to drift is small. The contribution of the SA602 to the VFO drift can, however, be significant. Unfortunately, the thermal properties of the various components can vary from device to device making it difficult to come up with a temperature compensation scheme that will work in every case.

In its "stock" form, my 15M Cub would drift down about 2 kHz during the first 10 minutes after a "cold start" and another 300-500 Hz over the next 5 minutes. It then settled down and would maintain a set frequency within a couple of hundred Hz or so over the next hour or two – provided the ambient temperature remained relatively constant.

Since temperature compensating a VFO can be a long and

frustrating exercise, I tried to convince myself that this was "good enough". However, after several QSOs during which I was continually "tweaking" the dial, I decided to bite the bullet and see if I could improve the situation. Well, I was very lucky; after a few hours (rather than a few days) of diddling with different capacitor combinations, I was able to reduce the drift to almost zero! The VFO now wanders up and down about  $\pm 50$  Hz during the first 10-15 minutes of warm-up, and then changes no more than  $\pm 25$  Hz during any 10-minute period. In one test, I left it running on the bench for four hours and the total drift was only 90 Hz. It did drift up and down some during that time, but never the less, this is a **big** improvement over the original drift!

The improvement was achieved by replacing C6 (originally a 150pF "mono cap") with three caps in parallel: A 100pF NP0 mono ceramic, a 10pF N900 disc ceramic and a 39pF NP0 disk ceramic (the two disk caps are soldered on the bottom of the PC board). For those not familiar with capacitor designations, "NP0" caps have very low temperature drift; typically less than  $\pm 100$  PPM per degree C. (The "mono" caps used in the Cub are supposed to be NP0.) "N900" means that the drift is "nominally" a negative 900 PPM per degree C. As explained above, this combination of capacitors may **not** work for your 15M Cub, and certainly not for other

band models.

If you want to try to reduce the drift in your Cub (or any VFO, for that matter), here are a few things to keep in mind:

- You won't be able to make any meaningful drift measurements immediately after touching a soldering iron to the rig. Let it sit with the power OFF for at least 30 minutes (preferably an hour) before making drift measurements.
- The 80 and 40M Cubs use "down conversion", meaning that the output frequency drift is in the opposite direction to the VFO drift.
- Some capacitor types – especially ceramic caps that have sat in a parts bin for a few years – need to be "conditioned" for several minutes to an hour or more in an operating circuit before they completely stabilize.

The best way to check for drift is with a frequency counter. You can also monitor the VFO on another receiver, but this is less precise. In any event, make sure that your measuring device is relatively stable; trying to check for VFO drift using a receiver that also drifts is a rather hopeless endeavor!

Ceramic capacitors that have a fairly linear negative temperature coefficient are designated "N470", "N750", etc. – the number indicating the nominal PPM/deg-C temperature coefficient. NP0 (also called C0G) caps have a temperature coefficient that is ideally zero, but in practice they may exhibit small positive or negative coefficients (more likely nega-

tive in my experience). NP0/C0G caps are available from most parts suppliers (Mouser, Digi-Key, etc.). N750, etc. caps are rather difficult to find, although some are often included in capacitor assortments sold by Radio Shack and others. Digi-Key carries Philips "N750" ceramic disk capacitors that have a specified temperature coefficient of  $(-1000 \pm 120)$ PPM/deg-C. Polystyrene capacitors have a small negative temperature coefficient of about 150 PPM/deg-C and are available from many parts suppliers. Silver mica caps have small (but usually unspecified) positive temperature coefficients.

If your Cub VFO decreases in frequency during warm-up, replace a polystyrene cap used for C6 or C7 with an equal value combination of NP0 and N750 (or poly) caps. If the direction of drift reverses, use a larger poly (or N750) cap and a smaller NP0 cap. If the drift is still down in frequency, try changing both C6 and C7 to combinations of NP0 and poly or N750 caps. You can also replace mono caps used for C6 (or C7) with combinations of NP0 and N750 (or poly) caps to reduce a negative frequency drift (this is the approach that worked for me).

If your VFO increases in frequency during warm-up, replace a polystyrene cap used for C6 or C7 with an equal value NP0. If the drift direction reverses, try combinations of NP0 and poly (or N750) caps to minimize the drift. If it is still positive, try silver mica caps

(which have a small positive temperature coefficient) in combination with NP0 (or poly) caps.

### **A Potential Source of Chirp**

After solving the VFO drift in my 15M Cub, I noted that the VFO frequency shifted slightly (~40 Hz) when the rig was keyed. I noted a similar change in VFO frequency under key-down conditions while changing the output power from zero to maximum (about 1.2W for my rig). Probing a little further, I found that the VFO frequency was sensitive to supply voltage; a 1V change produced a 700 Hz change in VFO frequency. The slight drop in the +12V supply line (~0.05V) when the transmitter was keyed resulted in the small frequency shift that I noted.

By the process of elimination, I finally determined that the VFO buffer, Q4, was the cause of the problem: JFET gate capacitance is a function gate-source voltage. Since Q4 is supplied by the "raw" 12V supply, any change in supply voltage results in a small change in the gate-source voltage and hence gate capacitance. Since the gate is connected via a couple of caps directly to the VFO tank circuit, a change in the gate capacitance will change the VFO frequency! The obvious cure is to supply Q4 from the regulated 8V output of U1. I removed R16 and connected the drain of Q4 to the output of U1 via a 47-Ohm resistor (100 Ohms would also work). After that change, the VFO frequency shifted less than 10 Hz for

a supply voltage range of 11.5 to 14V! And no detectable frequency shifts (<5 Hz) when keying the rig or changing the power level. Problem solved!

The VFO frequency sensitivity to supply voltage shouldn't normally be a problem unless you are running your Cub from a power supply with poor regulation. Under such conditions, some "chirp" might be detectable on the transmitted signal.

The "fix", however, is easy to implement. First, remove R16, either by breaking it and removing the pieces, or unsolder it using a fine-tipped iron and solderwick. Then solder a 33 to 100 Ohm resistor (1/8W works best, but 1/4W can be used) between the R16 solder pad that connects to the drain of Q4 and pin 1 of U1 (the

end of C3 that connects to U1 pin 1 is a convenient soldering point). The VFO frequency range will change slightly after this mod due to the lower drain voltage on Q4; you may want to adjust L3 if the shift is significant.

### Improving AGC Strong Signal Response

My Cub's AGC would "pump" badly on strong signals. Let me try to explain what I mean: When a very loud signal was present, the first character (dot or dash) caused a momentary (apparent) depression in audio gain (that's what I mean by "pumping"). The gain quickly recovered to the level set by the AGC and stayed there as long as the strong signal was being keyed within the recovery time of the AGC. This "pumping" was in addition to the slight "pop" or

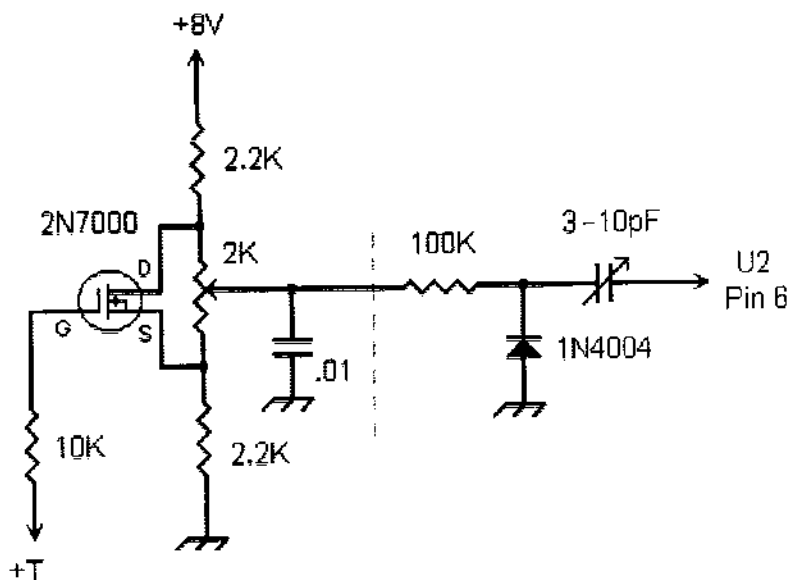

Fig. 4. Simple RIT circuit for the MFJ Cub.

"thump" on strong signals that is characteristic of audio derived AGC.

I increased R13 to 6.2K and that significantly reduced the initial gain drop, but (of course) the initial "pop" is still there. I found that my BFO was a little off, resulting in too much low frequency response. I reset it so that the IF filter passband peaks in the 700-800 Hz range and that also helped.

So... If you are experiencing AGC "pumping" in your Cub, first make sure that the BFO is set correctly and then try increasing R13 to something in the range 5-10K. (I used 6.2K just because I happen to have some 6.2K surface mount resistors in my "junk box"; a "through-hole" 1/8 W resistor can also be used.) I didn't try replacing R13 with a pot and attempting to find an optimum value.

### Adding RIT

Maybe I'm just spoiled, but I really missed not having RIT in my Cub. There are many RIT circuits that can be adapted to the Cub, but the limited space for added components led me to use the simple circuit shown in **Fig. 4**. The circuit is certainly not original, but I don't recall where I first saw it. A 1N4004 is used as a "tuning diode"; reverse voltage applied to it via the 2K pot varies its capacitance. The 1N4004 is coupled to the VFO via a small capacitor. I used a mini trimmer (Digi-Key part number SG1022-ND) to allow the RIT range to be set (a total range of 3-4 kHz is about right). How-

ever, a small fixed NPO capacitor can also be used; 10pF will probably be required for the 20M version, and 4.7 – 6.8 pF should work for other versions. The 2N7000 is used as a switch to set the voltage on the 1N4004 to "mid range" during transmit, thus disabling the RIT. The original circuit used an NPN transistor switch, but the small collector-emitter voltage present when the transistor was conducting resulted in the RIT having a slight effect on transmit frequency. The very low on-resistance (less than 10 Ohms) of the 2N7000 MOSFET completely eliminates that problem (a J309 or similar JFET should also work).

Note that there is no RIT on/off switch shown; if you wish to add one, use a SPDT type to switch the MOSFET gate resistor between +12V (disabled) and +T (enabled). I used a center-detent pot for the RIT control and did not find a switch necessary.

The RIT pot resistance can be anything between 1K and 10K. The resistors connecting it to +8V and ground should be approximately the same value as the pot and matched to each other to within a few percent.

The components to the right of the dotted line in **Fig. 4** should be mounted on the PC board using very short leads. I soldered one end of the trimmer cap to the solder pad of C6 that connects to U2 pin 6 and bent the other tab upward. The 1N4004 and 100K resistor were soldered to the upward-



pointing tab, and the anode of the diode was grounded to a ground feed-through to the rear of U2. I mounted the other components on a small piece of "perf board" and attached it to the RIT control solder tabs.

The "+T" control voltage can be obtained at the junction of R21, R23 and C43; simply solder a wire to one of the component's solder pads.

I mounted the RIT control in the upper left-hand corner of the front panel. The MFJ logo in that position can be easily removed, if desired, using denatured alcohol.

During initial testing, you may wish to ground the 10K resistor from the MOSFET gate rather than connecting it to +T. This will result in the RIT being enabled during transmit so that you can check the RIT range by measuring the transmit frequency. The RIT range will not be symmetrical; there will be about 20% more VFO offset on the low-frequency side than on the high side.

After the RIT circuit is installed, you will need to readjust L3 for the proper frequency range.

### **Odds and Ends**

#### ***Resettable Fuse***

The "fuse" in the Cub is simply a trace on the PC board that is supposed to open under high current conditions. (Look for a "zig-zag" trace near the power connector.) There are solder pads at each end of the trace so that a #30 wire jumper can be installed should the trace ever open. You can also cut

the "fuse trace" and install a real fuse, such as a 0.5A subminiature axial lead type, using these solder pads. I chose to install a "PolySwitch" resettable fuse so that I won't have to bother with replacing it should I ever have an over-current condition (caused, for example, by a reverse power connection). These are solid-state devices that have a very low resistance until a current threshold is reached and then the resistance becomes very high. They will remain in the high resistance state until the over-current condition is corrected. Slick. These devices are fairly inexpensive and available from Digi-Key. The part number for one that will trip between 0.5A and 1A is RXE050-ND.

#### ***Tuning Calibration***

Unless one uses an external frequency counter or other measuring device, determining the Cub's operating frequency is pretty much a matter of guesswork. There is not even a "logging scale" for the tuning dial that one can use to make a calibration chart. (Dial tick-marks are shown in the picture of the Cub on the ARCI web site, but apparently those didn't make it into production...) I like to know where I am operating, so I decided to make a "custom dial" using an inkjet printer and clear self-adhesive film. The film that I used is called "Repro Film" manufactured by Rayven Inc. This and similar film can be obtained from stationary stores and copy centers. I find it very useful for transferring

lettering to panels. After the film is applied to the panel, I coat it with a clear acrylic spray coating.

### **Power Output Notes**

My 15M Cub puts out about 1.2W when powered from 13.8V. The manual states that power output can be increased somewhat (up to 20%) by using a different RF power transistor in place of the 2N5109 supplied with the kit. I tried two different 2N3553's and one 2SC799 and did not see any significant improvement. The output was slightly less with one of the 2N3553 and slightly more with the other compared with the stock 2N5109. The output from the 2SC799 was significantly less at about 0.8W. The 2N3553 with the greatest output (about 1.3W became unstable when I accidentally keyed the rig with no antenna connected. I found no indication of instability with the other '3553, the stock 2N5109 or the 2SC799.

## **QRP Operating News**

By Richard Fisher, KI6SN  
1940 Wetherly Way  
Riverside, CA 92506  
[KI6SN@yahoo.com](mailto:KI6SN@yahoo.com)

Anyone who has ever been in the chase for DX at QRP levels knows that operating skill is a major part of the formula for success.

Even under not-the-best-of band conditions, some amazing distance work has been done by low power operators.

As you'll see in this quarter's column, having a solid and well-

I suspect that there is not enough drive, especially on 15M, to provide much more output than can be obtained from the stock 2N5109 (an MRF237, however, might provide a little more output because of its higher gain). The little surface mount PN2222A driver transistor could perhaps be replaced with a more robust 2N2222A, 2N4401 or 2N3904 to provide a little more gain, but I didn't try that.

My personal opinion is that any power increase obtainable by hand picking driver and final transistors would likely be less than 50% and not worth the effort. Any contact that can be made with 1.5W can probably be made just as well with 1.0W. Keep in mind that any circuit changes made in an attempt to increase power output run the risk of increasing spurious emissions as well.

thought strategy is one of the elements for making things go your way.

### **QRP DX: Some sage advice**

**James Duffey, KK6MC/5**, writes from Cedar Crest, NM that he is "not an avid DXer, but I try to work it if I hear it. Here are some tips that I find useful. They may or may not apply to (every QRPer's)

situation, but I think somebody may find them useful."

**Tip 1:** If you don't already have it, get a copy of Bob Locher's, W9KNI, "The Complete DX'er," (2nd Edition, ©1989 Idiom Press, Deerfield, IL). It is chock full of good tips. In a quick perusal of my ham library (located in three different places in the house) I was unable to find my copy. (Now, who did I loan it to?)

It is chock full of tips that will help you work DX.

**Tip 2:** You have to be on the bands to work DX, so get on as much as you can, even when the bands are rotten.

If you have trouble getting on, encourage yourself by putting a piggy bank on your operating desk and dropping a dollar bill in it every time you start an operating session.

You can pay for a K-2 in a little over a year and a half of daily operating this way.

**Tip 3:** Get on the bands at unusual times.

Go to bed an hour earlier and get up an hour earlier to operate around sunrise.

The bands are different then and you will have entirely different DX to chase.

Also you can take advantage of greyline propagation. Instead of going to bed on Friday or Saturday night after returning from a night out, brew a pot of coffee, get on the air, and operate in the wee

hours.

**Tip 4:** Nearly every DXer will tell you that listening is the key to DXing.

I agree, but you need to get on to listen so I emphasize getting on first. You need to listen with a purpose.

Develop a listening plan. I start on the highest band open, since absorption will be lowest and a QRP station will have the best chances for getting a contact.

I start at the low end of the band and go up. Listen to every station on the band.

Determine where the station is and who the station is talking to. Finding a domestic station working DX is almost as good as finding a DX station.

Listen for keys to DX: weak signals, fluttery signals, signals with a poor note, and a domestic station with excitement in the fist from working a new one.

After you have gone from one end of the band to the other, reverse directions and listen again. If I have not uncovered un-worked DX after a few trips up and down the band, I go to another band.

Not every DX station has a pileup, so I think that this way of listening is more effective than merely looking for a pileup.

**Tip 5:** It helps to keep a list of those stations you have worked and those you have QSLs from as you listen on the band.

You can do this on paper, or

some computer programs will track this information.

If you hear a station you need and can't work him right away it helps to put him in a memory.

Or note what frequency he is on, so you can work him later.

**Tip 6:** DXers, like you and I, are creatures of habit.

If he was on a certain band at a certain time one day, the chances are good he will be on at roughly the same time, and band, on another day.

**Tip 7:** Knowing when to listen is helpful. If you don't have or use a propagation program I suggest getting one and using it.

It will tell you statistically when the band is open to where.

It doesn't do much good to look for DX on a band that doesn't support DX.

Also, monitoring the NCDXF beacons help to tell you if the band is open, and to where the band is open.

**Tip 8:** If there is a DX packet cluster in your area, monitor it for DX alerts.

This information is also available on the Net, but is less localized, so you need to wade through a lot more posts to find something useful.

Before the DX Clusters were around, many stations announced DX on the local repeater or gave a friend a phone call when a new one came up.

You might get some of the more avid DXers in your area to help you out this way.

**Tip 9:** Now would be a good time to upgrade if you don't have an Extra Class license, as there is lots of DX in that lowest 25 kHz.

With high CW speed no longer a requirement for the Extra, those DX rich portions of the band should be within every QRPer's reach.

**Tip 10:** As many QRPers found out in the IARU contest, contests are a good source of DX.

Thirteen new ones in a weekend is a pretty good accomplishment, particularly given the summer conditions.

There are several fall / winter DX contests which should have better conditions.

If you are looking for countries, do not expect to operate the contest as you normally would.

Search and pounce, and only work those new ones you don't have QSLs from.

In the early stages of the contest the pileups will be horrendous, but you may have some luck working them, particularly on the higher bands.

At the end of the contest the big contest stations, even the rare ones, will be begging for contacts and there will be relatively little competition for their affections.

**Tip 11:** Some contests are better than others for new ones.

the ARRL DX contest is good, as it is the World working the U.S.

The CQ DX contests are good as they take place over holiday weekends so you can plan your sleep around the contest.

When 10 meters is open, the ARRL 10 Meter contest is very productive for new ones.

**Tip 12:** Many of the big gun contesters set up a few days prior to the contest, and they can often be worked then.

This is particularly true for those big gun East Coast DXers who go down to the Caribbean and operate from exotic islands with special stations during contests.

**Tip 13:** Some big contest stations don't QSL contest QSOs as they work so many stations in a contest, so work those countries you don't have QSL cards from as often as you can (different stations / bands of course) in hopes that at least one will QSL.

**Tip 14:** Many contesters run multi-multi stations, which means that they have a station going on each band around the clock, whether the band is wide open or not.

You may be able to take advantage of this by working long path during a time when the band is not normally open and there is not much activity.

It is surprising where 10 meters can be open to at 0300 (local) in the morning when some-

body is on there.

**Tip 15:** Being a contrarian also helps a bit in contesting.

A big contest takes a lot of the competition off the streets.

Working DX on the WARC bands during the ARRL November Sweepstakes is a good strategy, as most avid contesters are also DXers, and the competition is gone, but the DX is still there as they can't work Sweepstakes!

This also works to some extent during regular contests; those DX stations who are not contesters are still on, usually on the WARC bands, and the competition for these stations is reduced as most of the potential competition is off working the contest.

**Tip 16:** DXpeditions can be useful, but I would concentrate trying to work them during the later parts of the DXpedition, as the big guns are usually out in force during the first stages.

**Tip 17:** In a contest or DXpedition, I would advise against telling the DX you are working that you are QRP.

That is extraneous information to him. He is trying to put as many stations in the log as possible as quickly as possible, and the QRP information slows him down.

**Tip 18:** The WARC bands are good hunting grounds as they seem less populated with DX

chasers than the normal bands, but there seems to be as much DX on these bands.

Ten megahertz, or 30 meters, is a particularly good band for QRP DXing.

The power limits, 250 watts, and the fact that most stations have modest antennas, means that the spread between the loudest stations on the band and the weakest is not that great.

**Tip 19:** There is often DX available on the SSB portion of the band when none is heard on CW, so if all you want are new countries I would also operate SSB in addition to CW.

I know this may be heresy to many readers, but it is true. If you want DXCC, mixed mode is as good as CW only.

**Tip 20:** I would take a look at your antenna patterns with a program like EZNEC to see if you have any nulls in your antenna patterns.

You can't work DX if you can't put a signal in the DX station's direction.

Depending on what antenna you are using, you may have a peak toward a particular direction on one band, and a null in another one.

You may wish to erect another antenna to fill in any nulls. Good luck in your chase. Having a goal is important in DXing too.

Let us know how it all turns out. We are cheering for you.

## Anatomy of a QRP DX QSO

**Karl F. Larsen, K5DI**, writes from Mesilla Park, NM, that "DX is defined as a station in another country you need for some certificate.

"You can spend a lifetime working on this one and for sure if you're using an invisible antenna.

"Contesting has a short time period and in the case of a Fox, a single station to look for.

"I enjoyed the Summer Fox Hunt pile up at the first of the time period; it is much like a DX pile up.

"The PSK Sprint in September found stations trying to work each other under conditions defined in the rules.

"DX has been very present from Europe on 15 and 10 meters.

"To work these guys you must copy them so you get their call-sign and QTH and name while they work someone else.

"Then when they finish with the contact you call the DX with a normal 3x3 and listen.

"If he comes back to another station you relax and wait. Then you again call the DX when he is done.

"This continues with either of two outcomes: You work him, or you quit or he fades out.

"On PSK I have been very lucky. Running 5 watts I have worked Russians with names like Segio, and Spaniards with names like Juan.

"It seems to me that the QRP

group is missing a bet.

"A lot of small rigs are made for 20 and 40 meters. My Ten Tec Argonaut covers also 15 and 10 meters.

"These bands have the DX on them loud enough for a QRP station to work them.

"In the sunspot maximum where we are now, 20 meters is not very special and 40 meters may be far worse than it is during sunspot minimum!

"All contesting DX and otherwise requires that the stations listen most of the time, and to be a success call at the right time and frequency.

"There are many who call even though they don't hear the station they are calling hoping . . .

"You need to keep your cool and not tell a person calling the DX while DX is talking that they have a suspect background.

"You just fume and hope the guy stays off long enough to work this DX running 5 watts."

### **Milliwatting and the DX chase**

**Jim Hale, KJ5TF**, writes from

### **IOWA QRP 10**

by Mike Fitzgibbon, N0MF  
mjfitz@uswest.net

A simple yet effective ten-meter QRP CW transceiver has long been high on the wish-list of many a QRP operator. The normally anticipated problems in building such a radio—stability, adequate receiver sensitivity, and

Kingston, AR that "Friday's mail brought me another DX QSL card!

This one is FY/DJ0PJ who was in French Guiana. He was running 5 watts from a QRP+ to a balcony dipole. I was using my K2, WM-2 and 10 meter quad, running 200 mW.

This QSL brings me up to a nice number in my quest for the Milliwatt DXCC award from QRP ARCI. I now stand at 70 countries confirmed, using from 5mW to 800mW. Some are from contests, and some from non-contest QSOs.

In contests I use hunt and pounce with my own mW twist to it. I have my log handy as I scan the bands, and look for new countries. Then I watch their pileup and choose a time when they have few callers. Even the rare ones have slow moments when a tiny milliwatt CW signal can make it. They are getting hungry for callers and will try hard to copy you. I have a list of all 70 DXCCs on my web page, check it out: [www.madisoncounty.net/~kj5tf/](http://www.madisoncounty.net/~kj5tf/)  
"Have fun!"

compact size are, however, actually far from insurmountable. A simple radio for ten meters, based on the now classic SST design by Wayne Burdick, N6KR, can easily be constructed by most anyone with rudimentary soldering skills,

a few hand tools, and a bit of patience. The inherent problems associated with placing such a modest design on the ten meter band can easily be overcome with the addition of a few simple circuits and modifications, and it will provide surprising performance.

By employing a varactor-tuned 16 MHz variable crystal oscillator (VXO), followed by a diode frequency doubler and one-transistor amplifier, the same IF scheme utilized by the 20 meter SST (and the homebrewed 15 M version) can be used to tune a bit more than just the standard QRP frequency in the 10 meter band. The radio described herein covers from 28.045 to 28.065 MHz in two ranges with considerable overlap by using two switched tuning diodes. It is dead stable, owing, of course, to the VXO. The frequency doubler/amp circuit is taken from *Solid State Design for the Radio Amateur* (an ARRL publication) and can be found on page 44, fig. 24.

The problem of reduced receiver gain at 28 MHz (compared to SST designs for lower bands) is addressed by adding a simple grounded-gate FET amplifier to the receiver front end. This preamp is a design from the late great Doug DeMaw's *W1FB's QRP Notebook* (page 61, figure 3-18A), and provides about 12 dB of gain. In a recent evaluation at Dave Fifield's radio lab (designer of the NORCAL-20 rig and owner/operator of Red Hot Radio) the

prototype receiver displayed an MDS of  $-138$  dBm.

By building the rig Manhattan-style on three small boards, the circuitry easily fits inside a Bud mini-box measuring a scant 5 x 3 x 2 inches. The boards are mounted lengthwise on their sides (vertically) on small right-angle brackets. Built this way, access to all trimmers is maintained, and there is plenty of room for everything with even a bit of extra room left over.

The performance, in the same vein as the SST, is quite good, considering the modest parts count. During prototype "field" testing, several DX contacts were made from western Iowa with the rig's two-watt output, including the Canary Islands, numerous South American stations and Hawaii, all accomplished with a simple vertical dipole hung in a tree at 30 ft. Any day the band is open, east and west coast stations are standard fare from the midwest. It is truly a lunch-box rig that is a real blast to operate, and, owing to the nature of the ten meter band, a for-real miniature DX machine.

Additional notable modifications to the standard circuitry include a sidetone (transmit monitoring) level control, TICK keyer, a three-turn tuning pot, and a MRF237 output transistor. Several other small changes are also made to the basic SST circuit, and will be duly noted in the construction details that follow.

This radio is quite simple. On



receive, incoming ten meter signals are first picked off the transmitter's low-pass filter and amplified by the FET preamp. This amplified signal is then fed into U1, the NE602 mixer/oscillator, where the 32 mHz VXO signal is injected. The desired resultant signal at 3.932 mHz, the difference between these two frequencies ( $32 - 28 = 4$ ), is then passed through the three-crystal filter and fed into U2, the product detector and BFO. Here the signal is mixed with the BFO signal which produces an audio frequency signal. This signal then passes through the two FET switches Q2 and Q3 and is then amplified by U3, a LM386 audio amplifier, to headphone level.

On transmit... the 32 mHz VXO signal is mixed with a 3.932 signal at U4 and the resultant 28 mHz signal is cleaned up by a double-tuned bandpass filter before it is amplified by U5, which also serves as a buffer. This signal is then fed into the transmitter final, a MRF237. Harmonic components are removed from the 2 watt signal by the low-pass filter and sent "out the door". On keydown, the FET audio line switches Q2 and Q3 are shut off by grounding their gates and the desired level of "sidetone" signal (actually transmit monitoring) passes around these FETs through a trimmer resistor, R7. On keydown the input to the RF preamp and the first mixer are also grounded. Keying is driven by a

TICK electronic keyer located on the VXO board (see the parts list for supplier).

If you are new to homebrewing or unfamiliar with the SST design it would not be a bad idea to take a look at the original SST article which appears in the spring '97 issue of *QRPp*. Additionally, it is also recommended that you also cast an eyeball or two at the winter '98 issue of this same publication. It contains the excellent 2N22/40 transceiver construction article by Jim Kortge, which is also built Manhattan-style. Jim did a great job not only in building the radio but also in writing it up, and it contains many useful ideas and building techniques.

## **BUILDING TOOLS AND TECHNIQUE**

This radio is built using the Manhattan style. The parts, when installed on the pads, tend to resemble the square-laid avenues and streets of that famous Big Apple isle. That is, the parts rise from the main board like miniature buildings and skyscrapers. Parts are mounted by using small pads of single-sided circuit board which are glued to the main circuit board, which is also single sided (although double-sided will also work just fine). An inexpensive sheet metal punch (see parts list) is used to make these pads, and in this project they are sized 5/32 inch. I found that this size is just about right for most work. Punched any

smaller than this, the copper tends to easily loosen from the fiberglass board material upon heating. This size also works well around the IC sockets, a necessity in this case. The pads are secured with ordinary household superglue. The liquid type of superglue is used and not the gelled variety. The gelled variety takes much longer to set up than necessary.

Before gluing the pads down, it is a good idea to give them a swirl or two on both sides against some medium-fine sandpaper to remove burrs and/or contaminants. Also, a freshly exposed copper surface on the pads will solder more readily. Additionally, frequent use of a small piece of paper towel doused in methanol or a favorite solvent will keep the board clean and body-oil free as you go...so the glue will stick well. And while on the subject of sticking... It is highly advisable to make sure you get the pad just where it should be as you press it down against the board. It takes but a very few scant seconds (like three) for the glue to set up. However, if a mistake is made all is not lost... a pad can be knocked loose by a sharp lateral blow using a flat-bladed screwdriver as a punch. Commercial superglue remover (gelled acetone I believe) can then be used to dissolve the hardened glue on the main board. I use *Duro* brand cement and remover.

The amount of glue needed to secure a pad is a drop about the size of the pad itself, or just slightly

smaller. Any more than that—and the pad tends to skate around in the pool as you press it down to the board where it will stick immediately. The pads can be placed onto the glue precisely with a set of forceps (also know as “hemostats”) and held with the tip of the jaws or a pencil eraser until the glue sets. I use a set of 5-inch curved forceps for all of my small component lead bending and component placement. They work very well for this type of thing. Having the ability to lock a component lead in the jaws and hold it at any angle with two fingers while soldering is pretty much a basic necessity here. Get a good set of 5 or 6 inch curved forceps...Mouser (parts list) sells a nice set for about \$6. Radio Shack sells a set but in my experience they are of inferior quality and do not lock or grip well.

A great deal of the “building” with this radio is simply bending the leads and fitting the parts in a compact, space-saving manner. It may take more that one of these fittings to correctly trim the lead length and bend the wire just right for some of the parts, but the effort and time you invest in doing so will pay off in a good looking machine that works well. This project is easy to construct and get going owing to the simple basic circuits incorporated in this design. If you have a little soldering experience under your belt and have the desire to homebrew a rig this is an excellent place to start.

For a warm up on this type of construction, and especially if you need a circuit to match the crystals for this radio, you may want to build the crystal oscillator from the 1996 ARRL Handbook, pp 27.5. It is called a Crystal Controlled Signal Source. Doing so will not only give you a bit of practice, but also a useful little circuit as a bonus. And, with an appropriate crystal, it can also provide a stable signal source for other projects.

### **START BUILDING**

It is a good idea to first cut and fit the circuit boards and mount the controls and connectors in the enclosure. That way there are fewer surprises. The radio is built on three small boards. The VXO/doubler and receiver boards are identical in size and mounted back to back (glass to glass) on the bottom of the box with threaded 4-40 right-angle brackets. Alternatively, you might try soldering some brass nuts flush with the bottom edge of the boards (a good suggestion by Doug "Da Man" Hendricks, KI6DS). These two boards are 1 7/8" high (mounted vertically) and 4 1/8" long. In addition to the VXO/doubler, and keyer circuit, the center board also holds the voltage regulator and two caps which form the 8 volt supply. This regulator is mounted up high on the board near the "top" edge so connections to it are easily reached after the board is installed in the enclosure.

When mounting the boards in

the box you should allow about 3/4" height for the components of each of the three boards and mount the boards accordingly. Be sure to give yourself a little space between the ends of the boards and the controls, jacks, etc., to run wires and such. I mounted the keyer annunciator on one-half of the back panel and all the jacks/connectors on the other half. A large, high-efficiency "beeper" (parts list) was used so that I could readily hear it with over-the-ear phones.

A three-turn potentiometer is used to tune the VXO. It provides just the right amount of spread for the tuning range. A single-turn unit might be used, although the tuning would be extremely sharp since the range covered by each tuning diode is approximately ten kHz. A ten-turn pot could also be used, and can probably be found for a buck or two less than the three-turn, but you will do a lot of dial spinning with that set-up. Additionally, if you only want to tune on/near the QRP frequency of 28.060 MHz, you can forget the DPDT switch and second diode and just install the MV209 varactor on the VXO board. The tuning inductor for the VXO is wound on the core using #26 enameled wire. Don't use wire smaller than this...the core is suspended between the range switch and the VXO board by this wire and wire much thinner than this probably won't be strong enough to support it adequately.

First build the VXO and doubler along with the 8 volt regulator and install this board temporarily in the enclosure with the associated parts (tuning pot and DPDT switch with diodes mounted on its top and bottom (see building diagram). Add an extra turn to the VXO inductor RFC5 when you wind it (make it 27 turns) and then if simply expanding or contracting the windings does not get you in the range you want it is easy to remove one turn. Of the three 10 M rigs I have built all have 26 turns of #26 on the core and tune the same ranges. Also, when mounting C33, angle the trimmer "up" a bit so that it can be accessed from above for adjustment after the transmitter board is installed.

The 1N914 diodes in the doubler should be matched to help suppress the fundamental frequency (16 MHz) at the doubler's output. You can use the "diode check" function of a DVM or alternatively, run a little current through them (10k ohms in series with 12 V will work nicely) and measure the voltage drop across the diode's leads with a DVM on the low range (readings will be .5-.7 volt). Match them within a few millivolts if possible. Diodes from the same "batch" tend to be similar in this parameter so this is not a difficult thing to do if you get a couple of dozen diodes from the same source. They're cheap and commonly used in QRP equipment.

After the VXO/doubler is built test its operation. The VXO oscil-

lator runs on 8 volts and the 2N2222 doubler amp requires 12 volts. Run the grounds on the tuning pot and the switch to the board. Put a scope on the output of the doubler (secondary of T4) and adjust C33 for the best-looking (consistent amplitude) 32 MHz waveform throughout the tuning range of both diodes. This may not be the setting that results in the absolute highest output at any one point, but you should see something around 1.0 V pk-pk or so, depending on the gain of the 2N2222, when it is correctly adjusted. If you don't get any output, check the oscillator for operation with the scope (at C30) or listen with a receiver (set for CW or SSB) at 16.0 MHz. Place the receiver's antenna wire near the board...it will be very audible if it is running.

Just an aside here...I generally check most of the parts before installing them with a DVM, a cap/inductance meter or a transistor tester... I even check the resistors if the markings are small or at all questionable. Then all I usually have to look for is a wiring mistake if it doesn't work...usually...

After you get the VXO going, add the keyer circuit. The IC chip and all the other ICs are mounted in a low-cost machined-pin IC sockets (parts list). The pins are bent at 90 degrees outward so that their ends lie flat on the pads for soldering.

Some general IC socket

mounting guidelines. One can only bend the pins once...they tend to break if you try straightening them. But...if one of them ends up at an undesirable lateral angle, the whole pin (on these particular sockets at least) can be rotated in the socket body before the chip is installed. If a pin is unused it should be cut off from the socket at the bottom of the socket well. Pins 1,4,5, and 8 should usually be bent out "lengthwise" from the IC socket (see layout) unless they are grounded. These four pins (some or all) are often the main support for the IC, along with any grounded pins. If a pin is to be grounded, it can be bent out slightly or simply trimmed a little bit so that it just touches the copper ground plane for soldering. Often it may be necessary to locate the pads for the middle pins (2, 3, 6, 7) at a slight distance away from the end of the bent pin in order to avoid shorts between the pads. This gap between the end of the pin and the pad can be spanned by the component lead or a short wire and the end of the lead and the pin overlapped 1/16" or so and simply tacked together with a small blob of solder.

To mount the sockets, after bending the socket pins appropriately, mark the copper groundplane with a pencil dot for each pad location. Place or hold the socket at the intended location and make a mark at the end of each now-bent mounting pin. If one or more of the pins is re-

moved, you can use its next door neighbor as a mounting pin for that side/end of the socket. This is what is done with the LT1252 driver chip in the transmitter. Pins 1, 5, and 8 are unused, so they are trimmed off. Pins 2, 3, 4, 6, and 7 are all then used as mounting pins (see layout)...there is enough room to get pads under all the ends of the pins in this case without a risk of shorting. It takes a little bit of care to do this, but once you get the hang of it, laying down pads and mounting the parts will go quickly and easily.

## RECEIVER BOARD

First, a little bit about crystal procurement and matching. These crystals are ordinary inexpensive microprocessor crystals. Buy a lot of at least 10. From the last set of 20 purchased from Digi-Key it was possible to match up five sets of three...enough to build five filters. It is only necessary to match the three crystals for the filter closely, within a spread of 25 hertz or less. The BFO and transmit mixer crystals X4 and X6 can oscillate a bit further from the filter crystals and work just fine since they are "bent" by their tuned circuits. If these crystals are within 40 or 50 hertz of the center of the filter crystals there should be no problem. Of course, it is best to get a group as closely matched as possible, but again, it is only necessary to find three closely matched ones for the receiver filter. When you match them, let

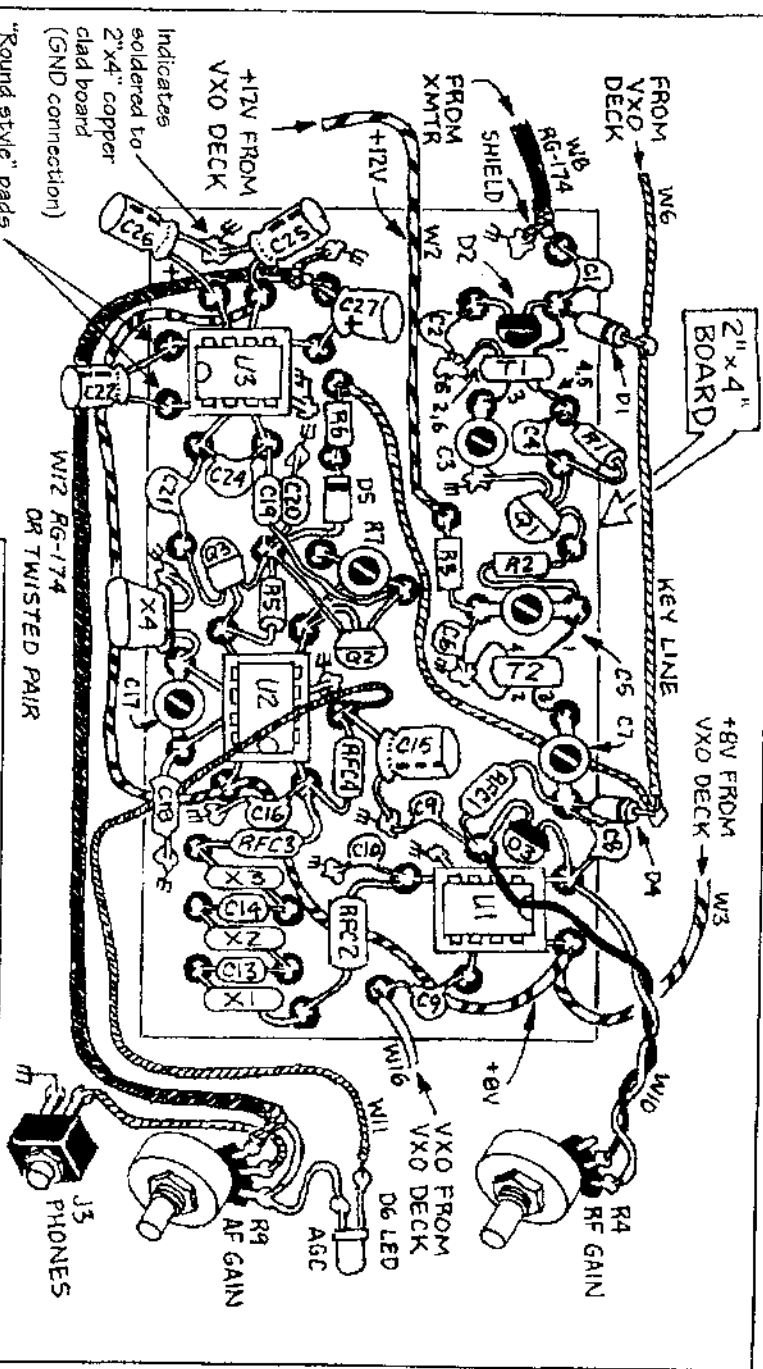

2" x 4" BOARD

+12V FROM VXD DECK

+8V FROM VXD DECK

FROM VXD DECK

FROM XMTR

SHIELD

INDICATES SOLDERED TO 2" x 4" COPPER CLAD BOARD (GND CONNECTION)

"ROUND STYLE" PADS (PUNCHED FROM COPPER CLAD) AND GLUED TO 2" x 4" BOARD

SECTION 1  
RECEIVE DECK

SED 1

IA QRP 10 TRANSCEIVER  
Designed by Mike Fitzgibbon, N0MF  
Drawn by Paul Harden, N4SN



J5 PHONES

R9 AF GAIN

AGC

D6 LED

W10

W11

W12 Rg-174 OR TWISTED PAIR

W3

W4

W5

W6

W7

W8

W9

W10

W11

W12

W13

W14

W15

W16

W17

W18

W19

W20

W21

W22

W23

W24

W25

W26

W27

W28

W29

W30

W31

W32

W33

W34

W35

W36

W37

W38

W39

W40

W41

W42

W43

W44

W45

W46

W47

W48

W49

W50

W51

W52

W53

W54

W55

W56

W57

W58

W59

W60

W61

W62

W63

W64

W65

W66

W67

W68

W69

W70

W71

W72

W73

W74

W75

W76

W77

W78

W79

W80

W81

W82

W83

W84

W85

W86

W87

W88

W89

W90

W91

W92

W93

W94

W95

W96

W97

W98

W99

W100



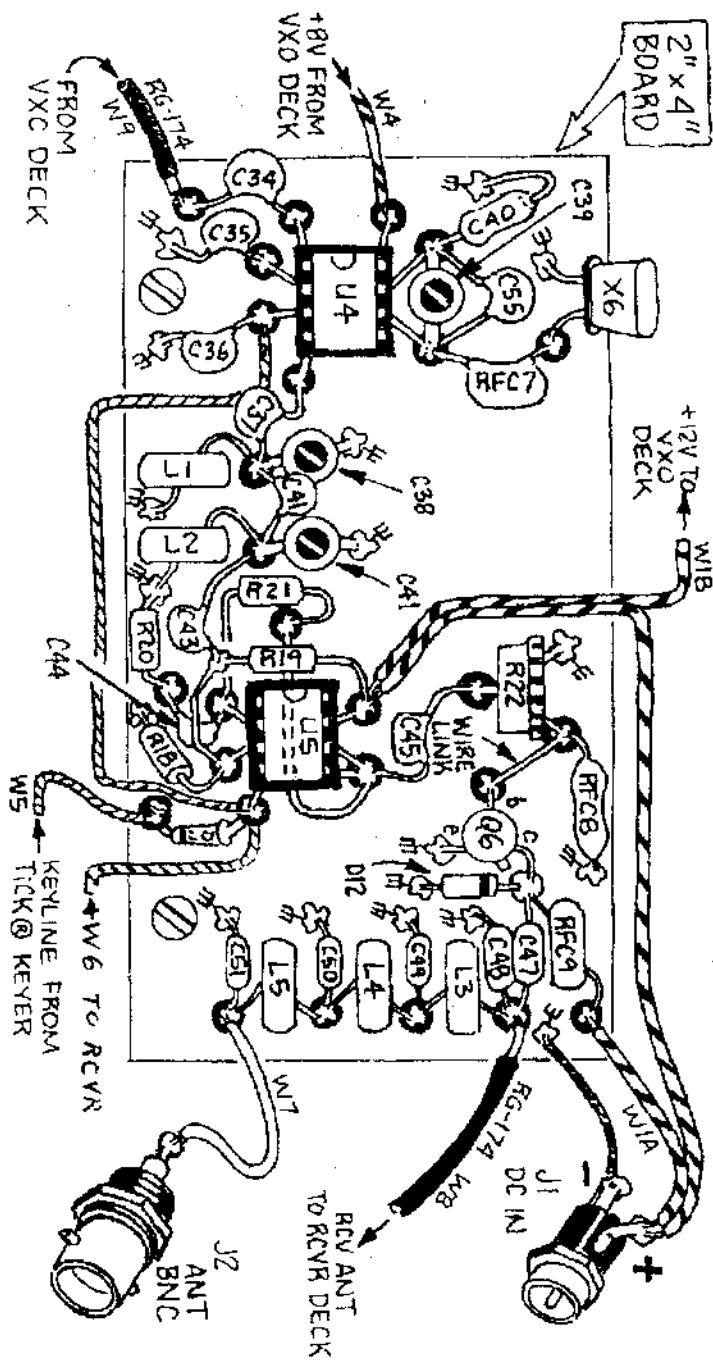

SECTION  
TRANSMITTER DECK

IA QRP 10 TRANSCEIVER  
Designed by Mike Fitzgibbon, NØMF  
Drawn by Paul Harden, N4SN



# CONSTRUCTION DETAILS

**T1** 8TP:16TS TAP AT 4T  
T37-6

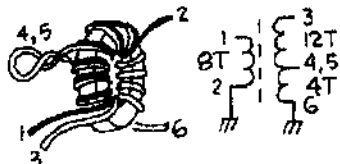

**T2** 16TP:8TS  
T37-6

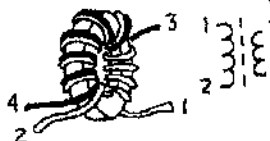

**D2, D3**  
MPN3700



A K  
A-D-K

**Q1, -Q4**  
J310



D S G

**Q5**  
2N2222



E B C

**Q6**  
MRF237



NON-STNDRD  
PINOUT



APPLY  
HEAT SINK

**RFC1**  
RED ORG



SILVER  
2.2μH

**RFC2, 3**  
12μH



BRN  
RED  
BLK

**RFC4** 1mH  
BRN  
BLK



BLK

**RFC6**  
BLK



BRN GRN  
15μH

**RFC7**  
RED BLK



22μH

**RFC8**  
RED



GOLD  
2.2μH

**RFC5** 26T  
T50-2



TO S1  
TO X5

**L1, L2** T37-6



17T

**L3, L4, L5**  
10T



T37-6

**T4**

19TP:3TS  
T50-6

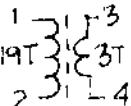

**T3**

10T BIFILAR  
FT37-61

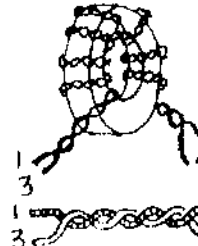

**U6**

78L08  
U101 78L05



OUT  
GND



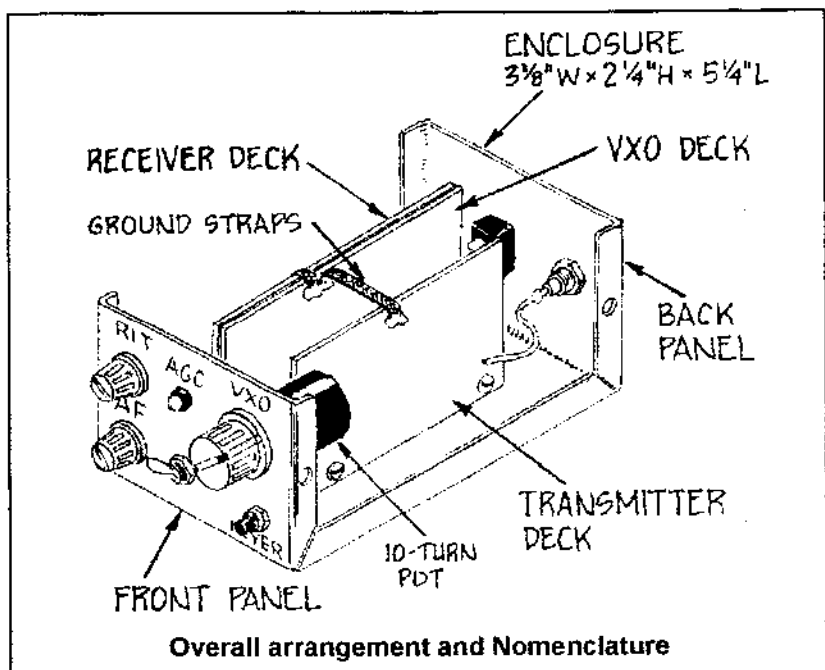

each crystal stabilize for a minute or so in the oscillator before you record the frequency. They are very temperature sensitive and just the heat of your finger will send them floating off. You can mark the last three digits of the resonant frequency with a fine-tipped laundry marker on the crystal can to make it easy.

I have purchased several such lots of crystals from both Digi-Key and Mouser and have never been disappointed. You may not be able to use all of the crystals, but you will most likely get several that are closely matched. It seems that if they come out of the same "box", the probability that they will be close in resonant frequency is fairly high. Also, the likelihood that

these crystals tend to be a close match is no doubt a function of their relatively low frequency.

Match the crystals using an oscillator (as suggested above) and frequency counter. It also may be possible to match them "by ear" using a receiver to listen to the oscillator signal by using some type of stable audio reference signal to compare the receiver audio against, such as the CW spotting tone of a transceiver... IF the transceiver's tuning is fine enough (and has a digital display with enough resolution) AND your ear is good enough. Another thing that is not a bad idea (but certainly not necessary) is to use a scope to check out each crystal's vigor as you are marking

them for frequency. Once I did have one crystal in a filter that was a little less active, and it did noticeably effect the gain.

The preamp circuit is fairly straightforward. The input and output transformers are wound using # 28 or 30 wire. I often mix smaller wire sizes a bit on these size cores if I have different colors to make it easier to ID the wire ends. You can certainly use both 28 and 30 wire here.

The tap on the secondary of T1 can be made by first winding 12 turns (pass wire through hole 12 times) on the core in either direction. The end for the tap is then trimmed to about 1.5 inches and is striped of enamel and tined with solder right up to the core. A second piece of wire is stripped/tinned a corresponding 1.5inch length and it is twisted together with the now-tinned length from the 12 turn winding coming off the core. Twist these two wires together right up to the core and run the soldering iron down them again to tin/solder them together. The second now-attached wire then continues the winding in the same direction for another 4 turns. There are other ways to make this tap, but this is a good procedure for someone new to this particular task. You have just wound a 16-turn winding with a tap at twelve (or four) turns. The primary winding for this transformer is then wound, *in the same direction*, starting at the end of the secondary nearest the tap, and laid, one-for-one, be-

tween the turns of the secondary winding for its eight turns. See the winding pictorial for further toroid winding details. Notice in the schematic that both the eight-turn input and the eight-turn output windings of the preamp on both torroids are laid starting over the grounded ends of the 16-turn windings. Doug, W1FB, always said to wind them like this to minimize capacitive coupling between the windings...so I always do...

Mount the preamp's FET using short leads. Although this is pretty much a fool-proof design (and tested as such by yours truly) it is simply good construction practice to do so in any kind of amplifier. This helps prevent unwanted parasitic oscillations and feedback. A 2N4416 FET can also be used in place of the J310. The 2N4416's case lead should be grounded in addition to the gate.

It is also a good idea to ground the end of trimmer C3 in the input circuit that is connected to the trimmer's adjustment screw: to avoid hand/tool capacitance effects when adjusting it, and in all cases where one side of the trimmer is grounded. In the type of trimmers used here this is usually the lead on the rounded end, but can be easily determined by simply measuring the resistance between each lead and the screw itself. It makes no difference with the output circuit trimmer C5 since neither end is grounded. It will be more sensitive to touch, of course, and a non-metallic tool is best

used for adjustment.

After the preamp is built add U1's socket and its associated components. When running the wires to the RF input pot R4 keep the leads as short as possible to avoid picking up unwanted signals. This is the reason that R4 is mounted very close to U1. Be sure to ground the cases of the crystals in the filter to help prevent filter blow-by. Also, just any old LED will not work the best for the "AGC signal-leveling device". You should use one of the LED types suggested in the parts list, or one of identical specs. J305 FETs will also work nicely as the mute switches in the audio line (Q2 & Q3) instead of the J310s if you have an over-abundance of them. Also, one side of the "sidetone level" potentiometer, R7, is left floating. You can mount that leg on a pad all by its lonesome self... And, unlike the SST, the audio output of this radio is not fed through both sides of the headphones in series. You *may* do that by floating the ground of the headphone jack (mount the jack in an insulator) and wiring up to the tip and band connections of the jack, but personally I don't care for the out-of-phase-sound that it produces. If your LM386 howls because of insufficient loading due to low-impedance headphones and you don't want to connect the headphone elements in series by floating the ground, try adding a 1 uF non-polarized cap across the phone jack.

After the receiver board is built, mount it and the VXO/doubler board in the enclosure and test it. You can use a short piece of insulated wire to run the VXO signal around the end of the boards and attach it to C9A's pad. RG-174 is used to carry the audio signal both to and from R9, the audio gain pot.

At this time any adjustments to the tuning range (adjust the number of turns/spacing on RFC5) may be made and you can determine the tuning range using a calibrated transceiver by transmitting into a dummy load at low power. Clip a short (two-foot) receiving wire on the input of the preamp. Peak the trimmers in the preamp and receiver with a non-metallic tool for maximum signal and adjust C17, the BFO trimmer, for a nice mellow-sounding tone of your favorite pitch. If you do not get two distinct peaks while turning the trimmers through 360 degrees you probably need to add or subtract inductance in that particular tuned circuit. This means that you are either peaking on the minimum or maximum capacitance of the trimmer and not at the desired peak of resonance, which should be somewhere between the maximum and minimum capacitance. That is, when you turn a trimmer through its range there are two settings which will produce the same overlap of the trimmer's plates and hence the same capacitance. If this doesn't happen, start by spreading or compressing the

turns on the inductor if possible, and if that doesn't work, add or remove turns or change the value slightly until you get two distinct peaks. You can then attach the input to an antenna and peak the trimmers again on some far-distant signals, while admiring the fruit of your work.

## TRANSMITTER BOARD

You are now ready for the final phase of the project. First, a little run-down on what is going on here. The 32 mHz VXO signal is fed into mixer/oscillator U4 and combined with the signal generated by the 3.932 mHz local oscillator contained in the chip. The difference, your soon-to-be 28 mHz signal, then passes through a double-tuned bandpass filter (C38, L1, C41, C42, L2) to clean it up a bit, and is then amplified by U5, which also acts as a buffer. The signal is then routed through the drive level control R22 to Q4, the final output transistor. Here the signal is amplified and sent through the low-pass output filter where the harmonics/spurs are removed. Nothing very complicated ... but it seems to work well.

The transmitter is built on a slightly smaller 3.5 inch board. A short piece of RG174 brings the VXO signal to the transmitter board. You only need to ground one (either) end of this coax. Mount the mixer U4 and the buffer/driver U5 just as you have done with the receiver/keyer chips. One new technique is used to make a

connection around U5. Run a piece of resistor lead *under* the socket between the pad that is connected to the 620 ohm resistor R21 (actually two resistors in series...a 510 + 120 ohm pair here...close enough) and the number six IC pin. This is one of those places where the hemostats will come in very handy.

The final transistor, a MRF237, has a unique pin-out...that is, its collector and emitter leads are *REVERSED*...if you do not want to kiss it goodbye, be sure you observe this. This device will yield an output of 1.5 to 2 watts or so, depending on your supply voltage and characteristics of the transistor. Also, a NTE 341 is listed as a substitute for the MRF237 and is available from Mouser although I have not tried one. Alternatively, a 2SC799 can also be used (reverse collector and emitter from pictorial) and it will yield about half the output (3/4 W.) of the 237, but it is several bucks less than the 237. The current price of the 237 at RF Parts is about \$10, not including shipping, \$25 minimum for order. At full output the MRF237 will get quite warm, so a snug healthy-sized heatsink is a necessity, and a little heatsink compound between the transistor case and the heatsink is a probably a worthwhile addition. Simply smear a small bead evenly around the inside of the sink at the bottom edge and let the transistor case spread it out as it is pushed into the heatsink.

Once you have the transmitter board done and the ICs installed, mount it in the box and finish the wiring. Mini-coax is again used to carry the signal from the transmitter's output filter to the preamp input. I also used a bit of desoldering braid to act as ground straps between the boards... otherwise the only good grounding the boards have is through the mounting brackets.

The big moment is at hand! Attach a QRP-level power meter (RF probe or scope will also suffice) and dummy load to the output and set the drive trimmer R22 against the stop to maximum (minimum resistance). Key the rig and adjust trimmers C38 and C42 for maximum output. If you can't get any output, turn R22 fully the opposite way and try again. If no output is still observed go back with your scope or an RF probe and look for the signal along its intended path. Check to see you have a 32MHz signal at the input to U4, then check to see if the local oscillator is running by checking for oscillation of the 3.932 crystal. This oscillator can be heard, along with the BFO (which you should disable first by lifting the lead to pin 8 of U1) on a receiver set for 3.932 MHz if you place the antenna wire close to the circuit. If all is well so far, then check for the signal output at pin 4 of U4 and so on through the transmitter circuit until you find the "interruption".

Using a second well-aligned 10 meter transceiver as a fre-

quency standard and test set-up, key the QRP 10 and adjust C39 to the correct offset. First, set up the test transceiver with a dummy load at 28.060 and attach a short pick-up wire to the QRP 10's antenna connector just to make sure you will hear the signal. Then transmit (a couple of watts will be plenty) with this second "test" rig into the dummy load and tune for the signal on the QRP 10. Now, without moving the tuning knobs on either transceiver, switch the dummy load to the QRP 10 and key it to transmit while adjusting the offset trimmer C39 until the signal from your magnificent creation is at a working pitch in the test transceiver. You may need to add a short receiving wire to the bigger transceiver if you cannot hear the QRP's signal. If you cannot adjust C39 to the correct pitch (due to crystal X6 being a little bit removed from the IF frequency) you may have to adjust the value of C55 slightly upward a bit, try a 39 or 51pF cap. This is no big deal and is very easy to do, but be sure to use a temperature-stable NPO type here. Yup, that NORCAL cap kit sure comes in handy about now...

Once the transmitter is blazing lightning bolts into your dummy load, adjust R7 for a comfortable sidetone level and re-peak the trimmers in the preamp and receiver (except for C17, the BFO) on a weak signal if you have not done so already. You should now have a fully-functioning 10 meter

transceiver. If not, and if you have tested most of your components before installation, you should look for incorrect parts placement/wiring errors by checking things against the pictorial diagrams.

One final note on operating. All SSTs require a fairly efficient set of headphones to produce good volume. The Radio Shack model Nova 43 headphones work OK if you can find some, as well as some others. I have also heard from several sources that the Sony brand of "earbuds" are also quite sensitive, in addition to some of Sony's over/on-the-ear stereophones. Often the sensitivity is listed on the outside of the package. If you still require more audio gain to run a speaker or a set of inefficient stereophones, add a small audio amp to the output. I installed a second LM386 audio amp in the prototype unit on a small board and it powers a large speaker very well without adding too much more to the current consumption. Of course, one could always use a sub-mini DPDT switch to bypass the extra audio

amp and cut off the current to it if extremely low current consumption is of particular concern. A good design for such an amplifier can be found in the circuit catalog section of the ARRL's "Data Book", page 8-4.

Lastly, I would like to thank Dave Fifield, AD6A, for his kind help with this project. Dave took the time to clean up the transmitter output and suggested a couple of other needed circuit changes. Also, I would like to thank Doug Hendricks for his fine job with the schematic (ALL Doug's baby) and his generous assistance and encouragement. A special thanks also goes to Paul Harden, NA5N, for his masterful and obviously time-consuming illustrations. I'm sure you will agree that Paul's electronic artwork adds tremendously not only to the ease of construction, but also to the overall quality of the article. It is much appreciated...I could have not done it without these three "pillars" of the QRP community. Their help was simply invaluable. Have fun!  
72, Mike, N0MF

### IA QRP 10 PARTS LIST

Please see legend below for suppliers

#### CAPACITORS

All caps NPO ceramic disc or monolithic 50 V unless noted otherwise

C41	2.2 pF
C1, C8, C34, C37, C43	5 pF
C55	27 pF
C9A	56 pF
C48, C51	82 pF
C10, C16, C28, C29	100 pF
C49, C50	220 pF



C13, C14, C18, C40	270 pF
C44	820 pF
C9, C11, C30, C31, C32, C35	.01 uF 20 % ceramic disc 50 V
C23, C24, C36, C45, C46, C47	.022 uF 20 % ceramic disc 50 V
C2, C4, C6, C19, C20, C21	.1 uF 20 % ceramic disc 50 V
C22, C26	2.2 uF radial electrolytic 25 V
C12, C25, C27	100 uF radial electrolytic 25 V
C15	470 uF radial electrolytic 10 V
C33	2-20 pF ceramic trimmer (DK, SG20015-ND; M, 242-4221)
C3, C5, C7, C17, C38, C39, C42	5-50 pF ceramic trimmer (DK, SG50015-ND; M, 242-9850)

## RESISTORS

all resistors 5%, 1/8 W carbon film (RS assortment)  
unless noted otherwise

R2	15 ohm
R17	47 ohm
R3, R16	100 ohm
R20	120 ohm
R1	220 ohm
R13	330 ohm
R15	470 ohm
R21	620 ohm
R6	1k ohm
R8	1.8k ohm
R14	6.8k ohm
R18, R19	10k ohm
R11, R12	100k ohm
R5	2.2 M ohm
R22	100 ohm side-adjust trimmer (RS, 900- 5918)
R7	5 M ohm side-adjust trimmer (RS, 900- 5932)
R4	5k ohm 1 turn miniature potentiometer (M, 313-1000-5K)
R9	1k ohm 1 turn miniature potentiometer (M, 313-1000-1K)
R10	10k ohm 3 turn potentiometer (A, 970- 1830)

## INDUCTORS

L1, L2	17 T (turns) T37-6 (RS, 900-7010)
L3, L5	10 T T37-6
L4	11 T T37-6
T1	8 T primary, 16 T secondary, tap secondary at 4 turns up from grounded end, T37-6
T2	16 T primary, 8T secondary T37-6
T3	10 T bifilar FT37-61 (RS, 900-6989)
T4	19 T primary, 3 T secondary T50-6 (RS, 900-7017)
RFC1, RFC8	2.2 uH molded choke
RFC2, RFC3	12 uH molded choke
RFC4	1mH molded choke
RFC5	26 T T50-2 (RS, 900-7015)
RFC6	15 uH molded choke
RFC7	22 uH molded choke
RFC9	8 T #24 FT37-43 (RS, 900-6988)

### SEMICONDUCTORS/ICs

D1, D4, D5, D9, D10	1N4148 silicon diode
D2, D3	MPN3700 PIN diode (A, MPN3700)
D6	hi-eff., 2.1Vf LED (M, 512-MV67539.MP10)
D7	MV209 tuning diode (A, MV209; RS, 900-5698)
D8	MVAM108 tuning diode, note: substitute part 1SV149 available from Doug Hendricks for postpaid—see address below
\$2	
D11	1N5817 shottky diode (A, 1N5817; DK 1N5817GICT-ND)
D12	1N4755A zener diode
U1, U2, U4	NE602AN DIP mixer/osc (RS, 900-7085)
U3	LM386 audio amp (RS, 276-1731)
U5	video amp (DK, LT1252CN8-ND)
U6	78L08 8V regulator, TO-92 package
Q1, Q2, Q3, Q4	J310 FET (RS, 900-5493)
Q5	2N2222A NPN
Q6	MRF237 NPN (RF)

### MISC.

S1	DPDT miniature toggle switch
X1-X4, X6	3.932 MHz crystals (DK, X013-ND)
X5	16.00 MHz crystal (DK, X143-ND)
Bud minibox, 5.25 x 3.00 x 2.13 inch (M, 563-CU-3006A)	
right-angle brackets, steel, 4-40 threaded, 4 pcs. (M, 534-621)	

small knobs, AF & RF gain (M, 450-2034)  
large knob, tuning (M, 450-2036)  
8-pin machined-pin IC sockets, 6pcs. (RS, RSU11354180; M, 575-199308)  
TO-5 heatsink, heavy-duty (DK, HS101-ND)  
BNC connector, female (M, 161-9323)  
3.5 mm 3-conductor "stereo" jacks (2 pcs)  
power connector (M, 163-4305)  
power cord with plug (M, 172-4201)

## KEYER

TICK keyer IC (ER)  
2N2222 NPN  
1 uF electrolytic, 25 V, (2 pcs.)  
SPST momentary push switch (RS, 275-1571)  
78L05 5V regulator, TO-92 package  
4.7K 1/8 W resistor  
machined-pin IC socket, 8-pin — see QRP 10 misc. parts  
piezo transducer (M, 539-PT2060W)

## SUPPLIERS

A Allied Electronics, 800 433-5700, [www.alliedelec.com](http://www.alliedelec.com)  
DK Digi-Key, 800 344-4539, [www.digikey.com](http://www.digikey.com)  
ER Embedded Research, Box 92492, Rochester NY, 14692,  
[www.frontiernet.net/~embres/](http://www.frontiernet.net/~embres/)  
M Mouser Electronics, 800 346-6873, [www.mouser.com](http://www.mouser.com)  
RF RF Parts, 800 737-2787, [www.rfparts.com](http://www.rfparts.com)  
RS Radio Shack, order locally, 800 the-shack,  
[www.radioshack.com/](http://www.radioshack.com/)  
sheet-metal punch Harbor Freight, 37405-OVGA, 800 905-5220,  
[www.harborfreight.com](http://www.harborfreight.com)  
Doug Hendricks, 862 Frank Ave., Dos Palos, CA 93620

## A MOSFET QRP GALLON

By Wayne McFee NB6M

Want an easy to build QRP Gallon Power Amplifier to use in conjunction with an existing 1 – 1.5 Watt transmitter? This amplifier formed the basis for the 5 Watt Mod for the SMK-1. It features the cheap, readily available, Radio Shack IFR510 Mosfet and can be built into a nice small package and used as an outboard PA, or, with appropriate QSK circuitry, can be built right into a rig.

Given the cost and scarcity of RF transistors these days, and wanting a 5 Watt RF amplifier that could be built either as an outboard amp or as a new PA for an existing rig, I was attracted to the IFR510 because of the successful use of this switching Mosfet in the 5 Watt Mod for the very popular 38 Special, a 30 meter NorCal QRP Club Transceiver Kit.

I was aware of the biasing problems that had been encountered in the 38 Special mod, and knew that I could avoid them by using an adjustable biasing circuit. However, I wanted to avoid both the added complexity of the bias circuit and the necessity of having to adjust it in the first place.

What I wanted was a gate circuit that would leave the Mosfet turned off until driven, provide good driving voltage to the transistor, and provide over-voltage protection for the gate itself.

I found exactly what I was looking for in a circuit developed by Michael Masterson, KA2HZA, and described in his December, 1986 QST article, "Three Fine Mice - MOusFET CW Transmitters".

Using this gate circuit provides gate protection via the zener diode, good drive to the gate of the Mosfet, no biasing circuit is needed, and the mosfet remains cut off until it receives driving voltage.

[See KA2HZA's article for further explanation.]

Although Michael's transmit-

ters were designed to get 12 or more watts out of a single IRF510 switching Mosfet with a 12 volt power supply, simply changing the output filter design values would give me the 5 Watt power level I was looking for. I found that less than a half watt of RF drive delivered to the gate circuit gives a full five watts out with the network values specified in Table 1. So far, I have tested the amp on 40 Meters and on 10 Meters. The 10 Meter amp gives 4.8 watts out with less than a half watt of drive.

In order to use the amplifier outboard of existing 1 - 1.5 Watt QRP transceivers, I decided to use a 3 DB resistive attenuator pad at the input of the amplifier to both reduce the drive level to the gate circuit and, even more importantly, provide a constant, non-reactive 50 Ohm load to the driving transmitter.

In order to keep it simple, a Double Pole, Double Throw toggle switch is used as a T/R switch to bypass the Power Amplifier completely on receive and for those times when the 1 Watt power level of the driving transmitter is sufficient or desired.

The Power Amplifier circuit is shown in Figure 1. The Output Filter Network Values for 5 Watts from 80 to 10 Meters are in Table 1.

As stated above, I have built and tested the circuit for 40 and 10 Meters so far. Indications are that the 10 Meter values would work on 12 Meters as well, but fur-



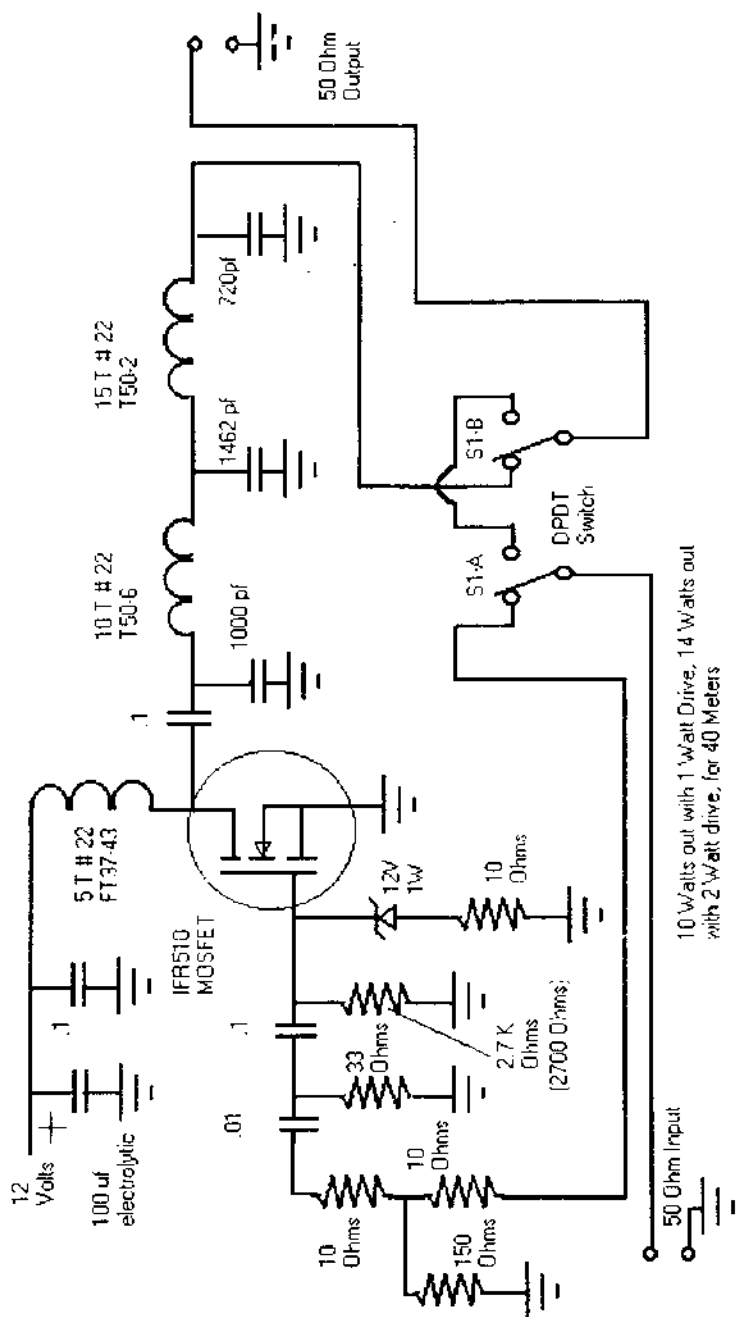

10 Watts out with 1 Watt Drive, 14 Watts out with 2 Watt drive, for 40 Meters

Enjoy, Wayne NBBM

Fig. 2

Table 1. Output Network Component Values

	C-1	L-1	C-2	L-2	C-3
80 Meters	820 pf	21 T # 24 T50-2	1600 pf	25 T # 24 T50-2	910 pf
40 Meters	390 pf	16 T # 24 T37-2	820 pf	19 T # 24 T37-2	470 pf
30 Meters	270 pf	13 T # 24 T37-2	560 pf	16 T # 24 T37-2	330 pf
20 Meters	220 pf	11 T # 24 T37-2	390 pf	13 T # 24 T37-2	240 pf
17 Meters	180 pf	10 T # 24 T37-2	330 pf	14 T # 24 T37-6	180 pf
15 Meters	150 pf	9 T # 24 T37-2	270 pf	11 T # 24 T37-2	150 pf
12 Meters	135 pf	10 T # 24 T37-6	230 pf	10 T # 24 T37-2	135 pf
10 Meters	120 pf	9 T # 24 T37-6	220 pf	11 T # 24 T37-6	120 pf

ther testing is necessary. A multi-band Power Amplifier module could easily be constructed using a rotary or other type of switch to select the appropriate output network for the band of operation desired.

An RF sensing relay circuit could easily be used to switch the amplifier in and out of the circuit automatically. One example of such a circuit is described in the March, 1999, QST article "A Broadband HF Amplifier Using Low-Cost Mosfets", by Mike Kossor, WA2EBY.

Should you desire more power output from the amplifier, twelve or more watts of output can be had by using the output filter network values published in Michael Masterson's original article.

I have built and tested this power amplifier on 40 meters using the output filter values shown in Figure 2, which resulted in a

power output of ten watts with a 1 Watt input, and fourteen watts out with 2 Watts of input. For these tests, the amplifier was being supplied from a 13.8 Volts DC power supply.

This project lends itself particularly well to "Ugly Style" construction. There are a small number of parts involved and there is a ready availability of parts going to ground throughout the circuit, which make natural stand-offs for the others. Should you prefer, it can easily be built "Manhattan" style, or on perfboard, or you can etch a circuit board for it. The circuit is simple and un-complicated, and it should be easy to lay out with whichever method you choose. The main thing to remember is to keep all leads short.

The Mosfet will need a heat sink, and can be mounted on the side or rear of the case for heat sinking purposes if a single-sided

PC Board or metal enclosure is used. If a non-metallic enclosure is used, a TO-220 style heat sink will do nicely. The higher power version may need a little larger heat sink, although my tests indicate that the TO-220 style heat sink is enough for that version as well. In either case, the Drain of

the Mosfet will need to be insulated from ground.

Whether you choose to build this RF Power Amplifier as an out-board amp, or as part of a transmitter, either at the QRP Gallon level or "almost QRO", you will be well satisfied with the results. Enjoy. Wayne, NB6M

## **Portable, No-Solder, No-Tuner, Resonant Twinlead 20M Dipole!!**

by Rich Wadsworth, KF6QKI  
320 Eureka Canyon Rd.  
Watsonville, CA 95076

This article describes construction of a portable dipole for 14.060 MHz that is relatively low loss and does not require an antenna tuner. Dipole construction has been written about so much that you might ask "What can Rich say that's new?". Nothing, really, but I haven't seen this particular antenna described, so it's my duty to do it.

My first attempt at a portable dipole was using 20 AWG speaker wire, with the leads simply pulled apart for the length required for a half wave top and the rest used for the feed line. The simplicity of no connections, no tuner, and minimal bulk was compelling! And it worked (I made contacts)! Jim Duffey's antenna presentation at the 1999 PacificCon QRP Symposium made me rethink that. The loss in the feed line can be substantial, especially at the higher frequencies, if the choice in feed

line is not rationally made. Since a dipole's standard height is a half-wave length, I calculated those losses for 33 feet of coaxial feed line at 14 MHz. RG174 will lose about 1.5 dB in 33 feet, RG58 about 0.5 dB, RG8X about 0.4 dB. RG8 is too bulky for portable use, but has about 0.25 dB loss. For comparison, the ARRL Antenna Book shows 18 AWG zip cord (similar to my speaker wire) to have about 3.8 dB loss per 100 feet at 14 MHz, or around 1.3 dB for that 33 feet length. Note that mini-coax or zip cord has about one dB more loss than RG58. Are you willing to give up that much of your QRP power and your hearing ability? I decided to limit antenna losses in my system to a half dB, which means I draw the line at RG58 or equivalent loss.

It is generally accepted that 300 ohm ribbon feeder has much less loss than RG58, though I can't



find it in the ARRL antenna book. Some authors have stated that TV twin lead has similar loss as RG58, which is acceptable to me. A coil of twin-lead is less bulky and lighter than the same length of RG58. These qualities led me to experiment with it. One problem is that its 300 ohm impedance normally requires a tuner or 4:1 balun at the rig end.

But, since I want approximately a half wave length of feed line anyway, I decided to experiment with the concept of making it an exact electrical half-wave long. Any feed line will reflect the impedance of its load at points along the feed line that are multiples of a half wave length. Since a dipole pitched as a flat-top or inverted vee has an impedance of 50 to 70 ohms, a feed line that is an electrical half wave long will also measure 50 to 70 ohms at the transceiver end, eliminating the need for a tuner or 4:1 balun.

To determine the electrical length of a wire, you must adjust for the velocity factor (VF), which is the ratio of the speed of the signal in the wire compared to the speed of light in free space. For twin lead, it is said to be 0.82, meaning that the signal will travel at 0.82 times the speed of light, so it will only go 82% as far in one cycle as one would normally compute using the formula  $984/\text{MHz}$ . I put a 50 ohm dummy load on one end of a 49 ft length of twin lead and used an MFJ 259B antenna analyzer to measure the resonant

frequency, which was 8.10 MHz. The theoretical 1/2 wave length would be  $492/\text{MHz}$ , or 60.7 feet, so the VF is  $49/60.7 = 0.81$ , close to the 0.82 that is published. A 1/2 wave for 14.06 MHz would therefore be  $492 \times 0.81 / 14.06$  or 28.3 feet. I cut a piece that length, soldered a 51 ohm resistor between the leads at one end, and hoisted that end up in the air. I then measured the SWR with the 259B set for 14.060 MHz and found the SWR to be 1:1, and the 2:1 bandwidth to be 7.76 to 8.47 MHz. That would allow the feed line to vary in length between 27.0 and 29.5 feet for a 2:1 maximum SWR, so the length is not too critical.

Now comes the fun part. With another length of twin lead, I cut the web between the wires, creating 17 ft legs, and left 28.3 feet of feed line. I hung it, tested, and trimmed the legs until the 259B measured 1:1 SWR. The leg length turned out to be 16.75 feet. (NOTE: the VF determined above only applies to the feed line portion of the antenna) There is no soldering and no special connections at the antenna feed point. I left the ends of the legs an inch longer to have something to tie to for hanging. I reinforced the antenna end of the uncut twin lead with a nylon pull tie, with another pull tie looped through it to tie a string to it for using as an inverted vee. When hung as an inverted vee at a height of 28 feet, the 1.2:1 SWR bandwidth measured from 14.000 to 14.130 MHz. To con-

nect the feed line to the transceiver, I use a binding post-BNC adaptor that is available from Ocean State.

I used Radio Shack 22 AWG twin lead that was available in 50 ft rolls. I haven't seen it lately, but I'm sure its equivalent is available somewhere. To have no solder connections, you need at least 45 feet. When I cut the twin lead to make the legs, I just cut the "web" down the middle and didn't try to cut it out from between the wires. It helps make the whole thing roll up into a coil, and the legs don't tangle when it's unrolled, since they're a little stiff. This antenna can be scaled up or down for other frequencies also. An even lower loss version can be made with 20 AWG 300 ohm "window" line, though the VF of that line may be different and should be measured before construction.

Wait, you say - "After all that talk about having it a half wave up, you only have it up 28 feet." I carry a 6 ft RG58 jumper to get it higher if the right branch is available. Since impedance at the feed point is 50 to 70 ohms, 50 ohm coax can be used to extend the feed line. I have used it in the field a few times as an inverted vee, at

various heights and leg angles, and used an SWR meter to double check its consistency in different situations. SWR never exceeded 1.5:1, so I feel safe leaving the tuner home. For backpacking, I leave the SWR meter home too!

And there's a bonus: As long as you use the balanced feed line (or extend it with balanced line), it CAN be used as a multi-band antenna, with a tuner, from 10 to 40 meters. I quote John Heyes G3BDQ from "Practical Wire Antennas" page 18: "Even when the top of the doublet antenna is a quarter-wavelength long, the antenna will still be an effective radiator." Heyes used an antenna with a 30 ft top length about 25 ft off the ground on 7 MHz and received consistently good reports from all Europe and even the USA (from England). It will not perform as well at 7 MHz as at 14 MHz, however, though 14 through 28 MHz should be excellent.

My shack 20 meter antenna is an inverted vee up 26 feet and I've made QRP contacts to New York, Florida and Alaska, and I expect equal or better performance from this one. I think it's a winner.

72, Rich KF6QKI

## Building the St. Louis Coil

by Andy Becker, W0NVN & Dave Gauding, NF0R

Illustrated by Paul Harden, NA5N

The Spring 00 issue of QRPP featured an article by Andy Becker and Dave Gauding on how to build a vertical antenna that used a large coil. [See Spring 00 QRPP, pp. 3 - 20, St. Louis Pocket Vertical]. Coil stock is very hard to come by these days, so Andy and Dave decided to be true hams,

they figured out how to homebrew their own. We had many, many requests for a pictorial description on how to build the coil, so we asked Paul Harden, NA5N to do a series of illustrations on how to build a coil, using Andy and Dave's method. This article is the result. Enjoy. Andy, Dave and Paul.

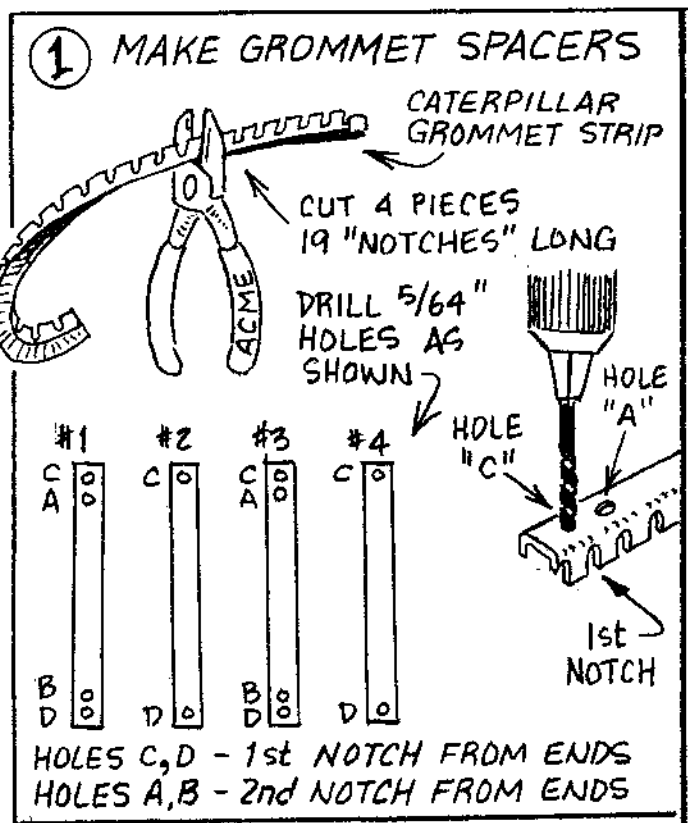

- ② PREPARE WINDING FORM  
 MOUNT GROMMETS #1-#4 ON A  
 3 1/4" MAILING TUBE EVERY 90°. DRILL 5/64" HOLES THRU TUBE  
 WHERE HOLES A, B, C, D OCCUR.  
 FASTEN GROMMETS WITH 2-56  
 HARDWARE THRU HOLES "C" & "D"

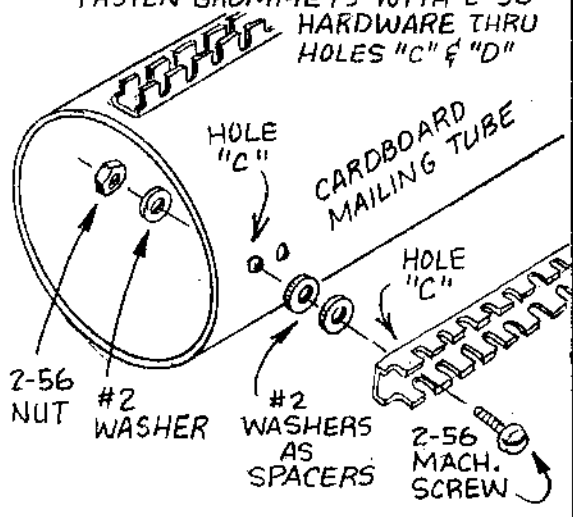

- ③ WINDING THE COIL  
 GROMMETS #1, #2, #3, #4  
 SHOULD BE MOUNTED  
 AS SHOWN.

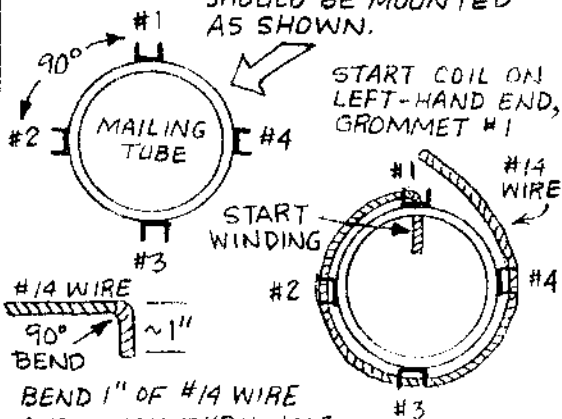

BEND 1" OF #14 WIRE  
 AND PUSH THRU HOLE  
 "A" (2nd NOTCH) ON #1 TO START. WIND  
 CCW. 1st TURN USES 2nd NOTCH  
 ON ALL GROMMETS.  
**NOTE:** 16 TURNS, 3 1/4" dia. = 14 FT. WIRE

#### ④ THE LAST TURN

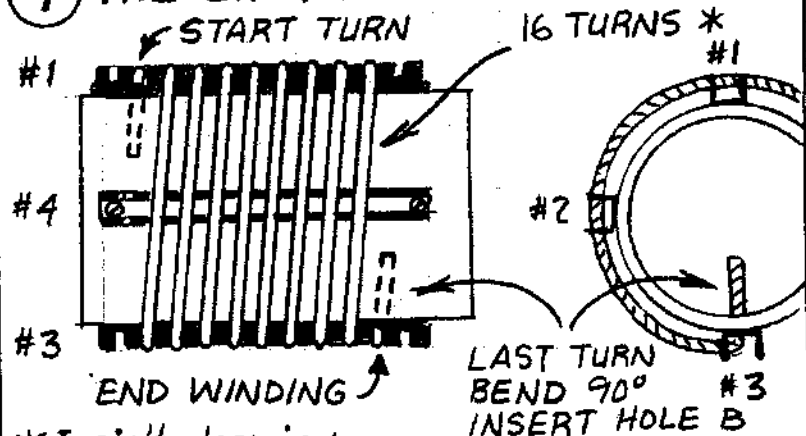

\*I ain't drawing  
all 16 turns!

#### ⑤ APPLY BEAD OF GOOP ADHESIVE ALONG TOP OF TURNS ON EACH GROMMET.

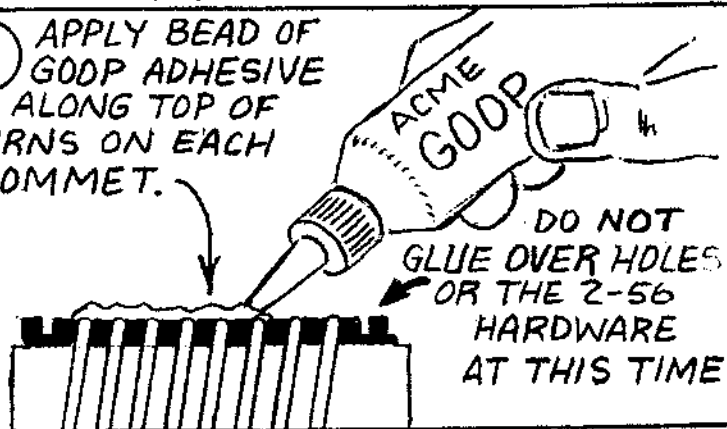

AFTER GLUING, EXPOSE TO  
A 100 WATT LAMP. WARMED  
ADHESIVE WILL FLOW THRU  
COIL WIRE FOR SOLID BOND.  
CURE FOR 24 HOURS.

⑥ 24 HOURS LATER...

REMOVE ALL 2-56 HARDWARE FROM COIL FORM & GROMMETS. PULL OUT WIRE STUBS FROM HOLES "A" AND "C".

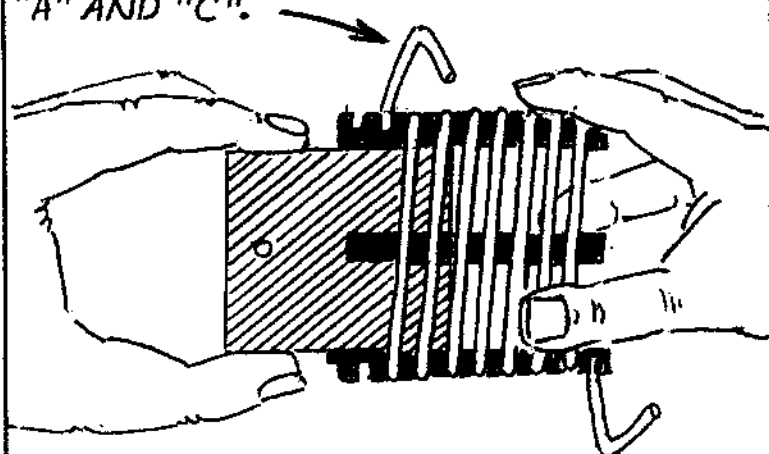

GENTLY SLIDE COIL FROM FORM  
BEND WIRE STUBS BACK INTO  
GROMMET HOLES WHEN DONE

⑦ BUILD COIL SUPPORTS (2)

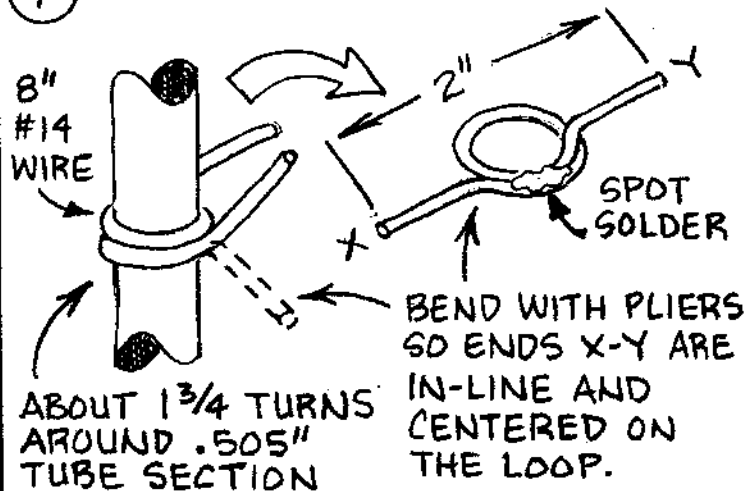

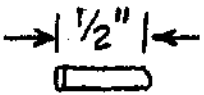
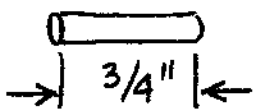
- ⑧ CUT  $3/32$ " DIA. BRASS TUBING INTO PIECE  $1/2$ " LONG AND ONE PIECE  $3/4$ " LONG FOR THE COUPLERS.
- 
- 

⑨ ASSEMBLE TOP SUPPORT

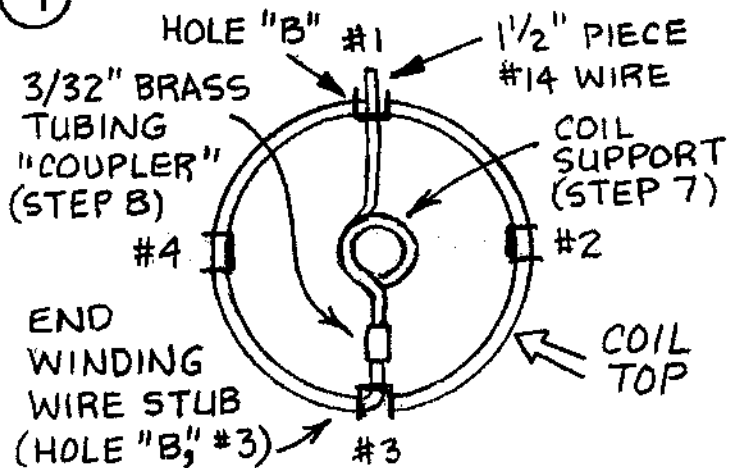

MOUNT TOP COIL SUPPORT TO COIL END WINDING WITH COUPLER, THEN SOLDER. ADD  $1/2$ " WIRE PIECE WITH COUPLER AND SOLDER.

## ⑩ BOTTOM SUPPORT

3/32" x 3/4"  
COUPLER



CUT ALMOST  
IN TWO

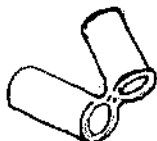

BEND BACK  
~300°

COIL  
BOTTOM

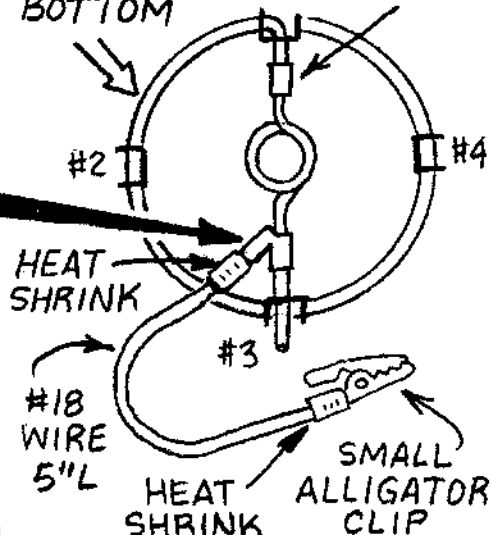

## ⑪ FINISHING TOUCHES

PLACE COIL ON .505" MAST  
SECTION & CENTER BY MOVING TOP  
& BOTTOM WITH SLIP FROM LOOSE  
WIRE ENDS.

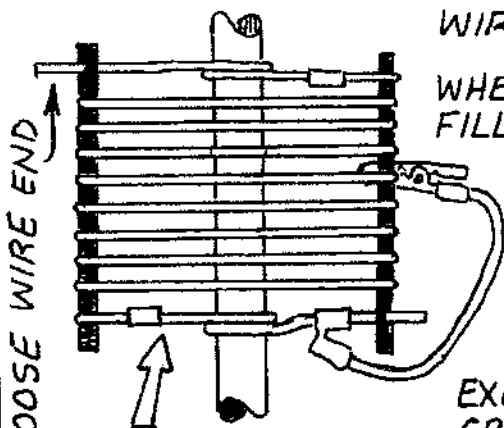

WHEN CENTERED,  
FILL REST OF  
GROMMETS  
WITH GOOP  
ADHESIVE  
PER STEP 5.

TRIM OFF  
EXCESS WIRE &  
GROMMETS IF  
DESIRED

COIL: 18  $\mu$ H  
Q: 300-350



## The Spring QueSO Party

by Bob Tellefsen, N6WG

Howdy, neighbor. Come on in and set. Have I got something to tell you!

You know, out in the desert, at the end of Highway 40M, there's that little town called Fortymeters. Nice little place, not as many people as it once had, but still a lot of nice folks there. I was out there about a month ago, and had several nice chats with the locals.

Then I got an invite to what they called an ARCI Spring QSO Party. I figured it was just misspelled, meaning a Queso Party, and you know how I love cheese. So I headed out there Saturday morning. When I pulled into town, something didn't look right.

This was supposed to be a big deal cheese party, right? Well, where were all the people? The General Store was closed and the lights were out. No one working there that morning. Well, I thought, it's a big deal party, so maybe they took the day off, and I'll see them there. Stuck my head in the Short Branch saloon, but nobody there either. Even the gas station was closed. Noticed there weren't any horses or cars on the

street, either.

Gettin' a bit spooky, you know?

Well, I figured everyone must be at the Queso Party, so started walkin' around, lookin' for it. Didn't have an address, but Fortymeters isn't a big place. Had to be somewhere close by. You know, I spent the whole day Saturday lookin' for that Queso Party and never did find it anywhere in Fortymeters.

I did run into a few other strangers huntin' around for it too, but nobody else had any better luck. We'd stop and chat a few minutes then move on, huntin' for that darned Queso Party. We pretty much decided that Fortymeters had become a ghost town, for the moment, anyway, and the Queso Party was a bust. Sure wonder what happened to it.

Anyway, think I'll run out there again in a while and see if anyone has showed up and any places open again. Maybe I'll find out where everyone went. Just can't figger it out. Sure sorry I missed out on that cheese feed Queso Party.

73, Bob N6WG

## An Integrated & Portable PSK31 Station for 80/20 Meters ... Without Using a PC

by George Heron, N2APB  
n2apb@amsat.org

PSK31 is the latest communications mode to sweep the interest of hams worldwide. Its inherent ability to dig out low, near-inaudible signals from the spectrum is ideally suited for low power QRP enthusiasts. But today's technology is tied to use of a portable computer, or even to a desktop computer. Thus the PSK operator is locked into a cumbersome and often fixed-location station. But there's hope!

Here I present the design and construction of a two-band PSK station utilizing a small and inexpensive DSP controller board coupled with the simple PSK transceiver boards from NN1G and Small Wonder Labs. I detail the techniques used to perform PSK processing in a small form factor, and the techniques used to create a novel and very functional "human interface" using a keyer paddle for input and audio Morse for output ... to create a PSK rig that can be easily taken to the field.

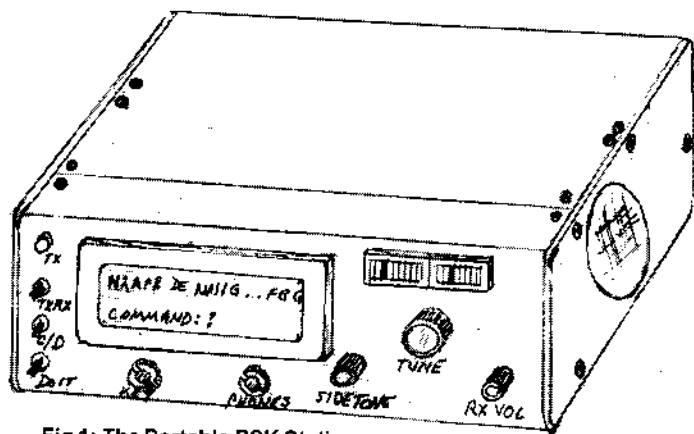

Fig 1: The Portable PSK Station  
(Full color photos can be found on the NJQRP website at [www.njgrp.org/portablepsk/](http://www.njgrp.org/portablepsk/))

I first became interested in PSK31 when it was introduced to us by Peter Martinez, G4PLZ in RSGB's RadCom magazine several years ago. I was able to get on the air with this digital mode using the various components -

PC sound card, interface cables, and software developed by the pioneers, and I had a great time making contacts all over the world.

I was later able to more effectively work this mode with the advent of some enabling software

and hardware technology. DigiPan, a PSK31 control program written by Skip Teller, KH6TY/4, has a panoramic graphical display showing all station activity within a specified band segment. What an astonishing improvement in the user interface for PSK31!

Then, around the time of the Pacificon QRP weekend last year, Dave Benson, NN1G designed and started selling the PSK-20, a single board transceiver kit dedicated for PSK3 operation. This board requires no physical tuning of components, and when used in conjunction with DigiPan (or other DSP software) it's audio passband could be analyzed and PSK signals across its 2 KHz window are able to be demodulated and displayed as ASCII text on the PC. What a marvelous improvement to size, stability and cost of a PSK station.

BUT ... even with these clever hardware and software designs, there still is room for improvement. The at-times big and cumbersome PC is still needed for PSK operation due to the spectral analysis and special character encoding requirements of this mode. And even if one were to use a modern laptop, taking these expensive and delicate computers to the field is a hair-raising experience. Plus, have you ever tried viewing the laptop's LCD display in the bright sunlight of a mountaintop QRP field adventure? It's very tough indeed to see the subtle spectral lines or even

the data on the screen! And that's only if your laptop's battery lasts long enough to enjoy the joys of PSK'ing out in the open. Sheesh, what's an industrious QRPer to do??

### **Smaller, Cheaper, Integrated**

They say that necessity is the mother of invention, but in this case we have the mother, father, two uncles and 39 cousins upon whose backs this ultimate solution is supported. I'm just the one to bring it all together with some conventional melting of solder, software glue and lots of experimentation along the way. A smile will slowly come to your face as you see how the various pieces of the puzzle came together.

There were **three major challenges**, or design goals as we say in industry:

1) Replace the computing power of the PC with something lighter and less power-hungry;

2) Replace the keyboard and display "input/output" of the PC with something more portable and ham-friendly; and

3) Find a small, trail-friendly, very stable, and inexpensive transceiver design to embed in the PSK station.

### **DSP Boards to the Rescue**

The challenge of finding suitable computing power to replace the PC was actually an easy one. The solution was already present in the form of inexpensive DSP "evaluation boards" provided by the major industry players like Motorola, Analog Devices and

Texas Instruments. These companies produce eval boards to help engineers quickly and easily try out their newer DSP chips - and it just so happens that these single-board DSP computers have tons of horsepower for just about any modem envisioned (PSK, RTTY, PACTOR, etc), audio filters, demodulation schemes, etc. For years, the communications wizards<sup>2</sup> in our ham ranks have been extolling the virtues of using these eval boards for our own purposes.

I selected the Motorola DSP56002EVM eval board as my main PSK modem processor. Johan Forrer KC7WW wrote a fabulous article in the August 1995 issue of QEX explaining how to use this board as a filter and a modem, and TAPR ultimately made a kit out of it for experimenters to play with.

The clincher for my selection of this board is that Peter Martinez, G3PLX, the father of PSK31, actually wrote a version of his PSK modem on this platform. Peter made his source code available for others to use and it explained how the whole system worked! And to top it off, G3PLX also provided the source code for his companion PC program that interfaced to the "EVM56K", thus clearly explaining the significant amount of extra processing required on top of what is done on the DSP board.

Now this need for a companion PC gets us back to the same problem as before, but we'll tackle it next!

## The "Human Interface"

In addition to providing additional processing - which I call "spectral processing" - this companion PC also provided the human interface. That is, its keyboard and wide graphic display provides the main way a human "talks" to a computing device. These I/O devices are common to most of us and we've grown accustomed to efficient use of them in everyday business and home life.

But once again stepping onto the shoulders of some uncles and cousins, we QRPers have found another very convenient, and more radio-friendly way to communicate with our complicated radio gear these days ... with Morse code! Yup, this "slow and antiquated mode of communications" comes to the rescue for our advanced technology project.

Okay, here's how we use Morse code for the I/O needs of a complicated piece of radio gear.

Considering that a PSK station controller needs to be provided data **input** by the human, a **standard keyer paddle** can be an elegant solution. Simple Morse code can be used to command the PSK controller as well as to actually send data to the receiving station. What could be simpler or more natural than using a paddle on the trail, or even on the desk at home?! Gary Diana, N2JGU of Embedded Research uses this technique in spades to control his immensely popular TiCK keyer

chip.

Good ol' Morse code comes to the rescue again when we consider the data **output** needs of a PSK31 station controller. Audio announcement of frequency has been popularized by Dave Benson, NN1G, another uncle-genius in our field who created an audio frequency dial that delivers the current settings of VFOs via Morse code through the audio chain of a radio. This same brilliant technique can be effectively used to convey the rig's state information, buffer contents, mode settings, and (especially) the PSK messages being sent to you by the station with whom you are in communication.

Of course there are some tricks and special sub-challenges to be solved when using Morse code for a digital mode, and we'll describe the solutions in a bit. But what a neat and efficient concept we've introduced: using a paddle as an input, and audio Morse code as output for a digital communications mode! Sort of "anachronistic", as they say in literature.

### **It's Truly a Small Wonder**

The last design goal was solved as easily as falling off a log, but it's so very important to make the brilliance of the solution crystal clear.

It's impractical to take one's multi-thousand dollar YeaComWood transceiver in most kinds of portable or field operation. You need to have a pretty darned stable VFO to operate PSK31, and

the little QRP kits these days (and even some of the bigger ones) just don't have the specs to easily accommodate the PSK stability demands. So it's important to use one of the more expensive rigs ... and one doesn't readily pick up one of these for an afternoon jaunt along the Appalachian Trail.

As mentioned a moment ago, Dave Benson, NN1G, developed a super simple, stable, no-controls single board SSB transceiver specifically geared for PSK use. It's wide audio passband allows a 2 KHz band of warbling, 2-tone PSK signals to get through and be presented to software for decoding. And the computer's precise tones can be presented to the linear transmit chain of this board to take care of the transmit half of the job. The PSK-20 board is sold as a kit by NN1G as proprietor of Small Wonder Labs. Dave also designed a simplified version of this initial board to work on 80 meters. He contributed this project to the NJQRP, who are kitting and selling it as the PSK-80 "Warbler".

The heart of using Morse code in these two boards, and other PSK-xx boards to come, serve beautifully as the RF element of the Portable PSK Station ... small, low cost, stable, no controls, perfect presentation of audio signal to a mating computing block. Like I said, brilliant!

### **Getting Down to Brass Tacks**

Okay, so enough of the background, selection logic and heroes upon whose shoulders we stand.

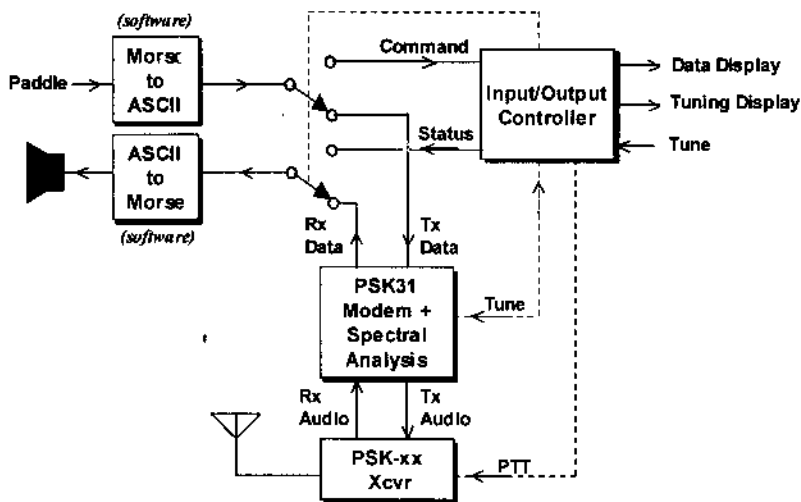

Figure 2: Simplified Block Diagram

Let's next get into the nitty-gritty of this project and describe how it works. Please refer to the Simplified Block Diagram (Fig. 2) as we describe the basic elements and interaction of the Portable PSK Station.

Since it is crucial to understanding the design and implementation, we'll reiterate the three *foundational elements* of this project: (1) use of Morse code for I/O, (2) use of a small computing blocks, and (3) use of the PSK-xx transceiver boards.

The heart of using Morse code in this project is contained in the Morse-to-ASCII, and the ASCII-to-Morse software blocks. "ASCII" is a 7- or 8-bit code that represents all possible "printable" (and non-printable) characters used within a computer system. These characters are often

thought of as the "text" in text messages.

The **Morse-to-ASCII** software block is used for taking input from the paddle in the form of a conventional keyer, and then converting the Morse code to an ASCII equivalent character. This ASCII character is either sent to the PSK modem and transceiver board for transmission as part of the communication, or it is sent to the Supervisory Controller and interpreted as a "command." (More on the Supervisory Controller in a moment.)

The **ASCII-to-Morse** software block is used to take either the ASCII "data" character received from the RF link, or the "status" character being generated by the Supervisory Controller and converts it to Morse code. This Morse equivalent of the data or status is

then modulated at a configurable frequency to give a pleasant tone and it's amplified and played out through the rig's speaker (or phones). In this way the operator hears the received signal and the system status as Morse code tones coming from the box.

(Note ... A clever trick is used to help the operator differentiate between data and status audio Morse signals. Data is audibly presented at the link data rate of 31 bps, and at a lower tone of about 600 Hz. Status coming from the Supervisory Controller is audibly played at a higher frequency of 750 Hz and at a faster rate of 25 wpm. These speed and tone settings are user configurable.)

At this point it's important to describe the **computing blocks** in the system. We've represented these blocks as the PSK-processing block, and the Supervisory Controller block.

As in each of the earlier PSK systems from Martinez, et al, there are two main computing functions required for the processing of PSK data. First, there is the **PSK modem**, which performs the actual modulation/demodulation of data in the form of handling phase reversals within precise timing windows. Second, there is an operation that I've dubbed **Spectral Analysis** that deals with the interpretation and conversion of the raw modem data to extract the data and to provide various information about the signal (phase/frequency, duplex operation, syn-

chronization, etc.). This Spectral Analysis block also typically provided the graphical user interface by indicating the spectrum or some kind of a tuning graphic (e.g., a radar-like circular, vector scope). In this project, we'll take the output of the Spectral Analysis block and use it to drive some other schemes for determining proper tuning.

The other main computing block is called the **Supervisory Controller**, and it performs as a low-level hardware device driver for the various controls and displays in the system. In essence, it is the traffic cop that determines where and how data, commands, and status flow in the system.

The Supervisory Controller also takes raw information from the Spectral Analysis block, processes it and drives a unique, special display device (LED bar graph array) to visually depict the phase condition of the received signal. With this clever display, the operator is able to tune for best reception and see the phase effects of his tuning. This tuning aid is another hidden gem in the design of this project's minimal user interface.

Tuning is accomplished with a shaft encoder on the front panel. An optional (though useful) 2-line LCD display is also on the front panel to optionally display the incoming data or system status.

The last element in the Block Diagram is the **PSK-xx transceiver board(s)**. The boards ac-

cept audio data stream from the Modem block, and present received audio to the Modem and Spectral Analysis block. Push-To-Talk control is provided to the PSK-xx board from the Supervisory Controller board, thus providing an automatic means of switching the transceiver between transmit and receive modes.

So as you can see, in it's simplified form, the Portable PSK system can be viewed as a way of sending data to a modem and transmitter, getting received data back, and displaying to the user the inherent quality or state of the received signal in order that rig can be accurately tuned.

## DETAILED SYSTEM DIAGRAM

Now that we have the basics covered, let's take a walk through the detailed representation of this Portable PSK project. We won't repeat the basic data, command and status flow described thus far, but we'll delve into some of the specific implementation approaches. Additionally, we'll focus in on the novel design aspects for tuning, display and control.

(Remember that the previous discussion was an idealized and simplified overview of the system. This section, however, describes the actual hardware and software comprising the Portable PSK project, and some real world trade-offs were necessary in order to achieve the desired results.)

First, let's identify the major elements of this real system.

Please refer to Figure 3: Detailed System Diagram for the following discussion.

The **PSK-20 and PSK-80 transceiver boards** are clearly indicated on the right side of figure 3. A DPDT-center-OFF switch located on the rear panel of the unit supplies 12 volt power to the selected board. It also simultaneously takes the RF output from the selected board and routes it to the rear panel SO-239 "ANTENNA" jack. A switch with a center-off position is used in order to have no board selected when not actively using the boards, thus saving battery power.)

The main scheme in using these transceiver boards is that we're providing "n bands of PSK operation". That is, you could use one board or 10 different boards to ultimately provide a very spectrum-capable PSK station. I would imagine that loading of the parallel-connected audio input and output lines would become an issue when using a greater number of boards, but that's an easy issue to solve.

Alternatively, in order to provide even more flexibility, these common audio input and output lines could be brought out to 1/8" jacks at the rear panel for connection to an external transceiver. Thus the Portable PSK unit becomes a bit less portable, but when coupled with an appropriately-stable transceiver on the bench, you'd be able to reach any frequency in the RF spectrum ...



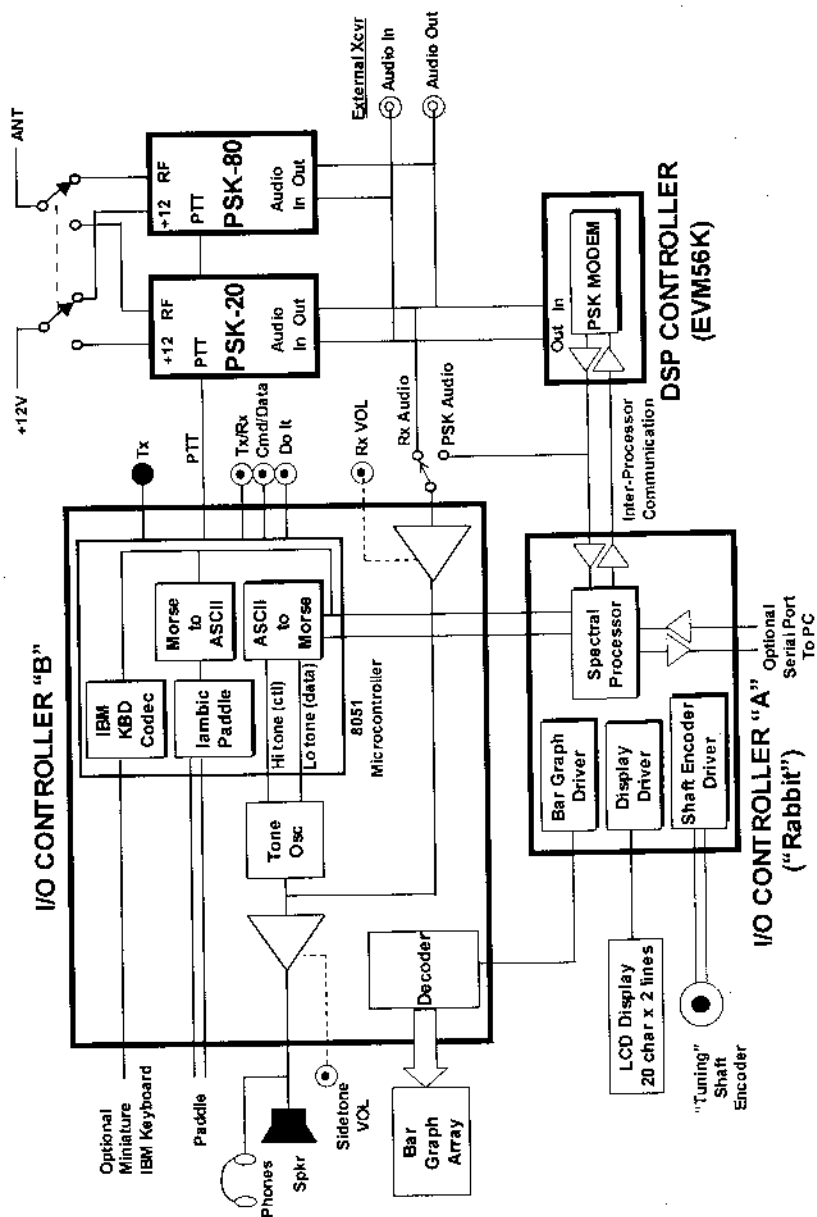

Fig. 3: Detailed System Diagram

LF to HF to VHF or beyond. The common denominator is the self-contained audio processing provided by this project, so any band that supports this communications mode is fair game!

The next thing to point out in the Detailed System Diagram is the separate nature of the PSK Modem block and the Spectral Processor block. Although the Simplified Block Diagram showed this as one functional block, they were implemented using two separate processor boards: the EVM56K board and a board called the "Rabbit".

The **PSK Modem function** is programmed into a standard, unmodified DSP56002EVM DSP controller board from Motorola. For all intents and purposes, the DSP code running on this board is the original design from G3PLX. The only implementation exception is that his PSK31.asm code module is placed into flash memory to allow self-booting without the need for an external PC on the serial port.

This board is a pretty neat project all unto itself. It formed the basis of many different amateur radio projects over recent years that have graced the pages of QST, QEX and RADCOM over the years in articles from the experts: KC7WW, G3PLX, KL7NA, and NA1DB. The Tucson Amateur Packet Radio (TAPR) organization even made a dedicated enclosure for the EVM board.

The PSK modulation/de-

modulation scheme used in the EVM56K board is a bit complex for the space we have here, but you can read the good description of Peter's DSP software in his two-part RadCom article. (See the detailed References section at the end of this article.)

Moving on now to the **Spectral Processor** block, you'll see that it is implemented on a "Rabbit" microcontroller card. This is an inexpensive, fast, and self-contained processor and I/O board with which one can conveniently program in the C language. Significant time savings were achieved by using this board.

"Spectral processing" is the term I use to collectively refer to the higher-level processing tasks performed on the Rabbit controller board:

⇒ Accepting the raw modem pump "receive data" from the EVM board. A serial communications line connects the two boards and a command protocol is used to handshake between them. Blocks of data are exchanged, as defined in the header files of both source code listings.

⇒ Delivering the "transmit data" to the EVM board, as obtained from the IO Controller board.

⇒ Interpreting the data to determine phase and sync of the data. This is the heart of the modem pump operation, as implemented in DSP code. Described in detail in the G3PLX references.

⇒ Providing a graphical representation of the phase via the bar

graph array tuning indicators. A software driver updates the bar graph array through a serial bit stream protocol over to a serial-to-parallel shift register on the IO Controller board, which in turn drives the LED arrays.

⇒ Providing the frequency tuning, AFC tracking, and presetting capabilities. This is at the heart of the system, whereby the Rabbit controller notifies the EVM56K modem pump of changes in user-selected frequency (as received from the IO Controller), and keeps the DSP modem tracking to the locked-in frequency to compensate for system drift. (There is little-to-no Rx drift in the PSK-xx boards, but oftentimes the transmitting station drifts out of the narrow audio passband of the DSP, and this AFC feature tracks the station ... for a while, at least.)

⇒ Providing the file logging, data capturing and canned messaging. Various human interface features are provided in the Rabbit software to handle capture of received messages, transmit of special buffers or electronic files, like "my QTH is... Rag here is ...", etc.

⇒ Performing a lookup table conversion of the Varicode data. This is another of the core functions provided in PSK31 processing, as developed by Martinez, enabling the mode to be as efficient as it is at the relatively slow data rate.

⇒ Providing the resultant ASCII data ultimately to the user, by sending formatted serial commands over the command link to

the "slave" IO Controller board, which in turn puts the data to the LCD, Morse annunciation, or to the optional external computer for logging and monitoring.

The software in this Spectral Processor board also originated from the G3PLX program called `psk31.pas`, which is software that normally runs on a PC and mates up with the modem pump software running on the EVM56K board. However with this Portable PSK project we converted the code to be run on a microcontroller, stripped out all of the conventional file I/O and screen user interface, and added a number of low-level human interfaces to allow it to operate in a small, self-contained box.

The last block in the system is the "**I/O Controller**" board. This is a custom-designed board which has an 8051-based microcontroller at its heart. This 8051 processor provides the Morse-ASCII-Morse conversions, keyer operation with the paddle, and optional keyboard input conversion.

The board contains two tone oscillators which are activated for Morse output of either data or status. Audio amplifiers are contained on this board to boost the level of the PSK receive data tones (more later on the valuable nature of these tones), and to provide the overall desired Morse output level. Serial data received from the Rabbit board is converted (serial-to-parallel decoding) in order to drive

the LED bar graph arrays.

The two boards (the Rabbit and the custom 8051 board) are referenced as I/O Controller Board A and B, respectively, in that they comprise the overall Supervisory Controller function in the system. These boards synchronize by means of an inter-board serial communication line. Special software is in place on the Rabbit to allow it to control the 8051 "B" board in a slave-like manner, thus simplifying some of the system software design.

Ultimately, one of the major improvements planned next for this project is a consolidation of the Rabbit's spectral processing functionality onto the 8051 board. This will provide an even more cost effective self-contained PSK solution. More on these "next steps" will be discussed toward the end of the article.

## THE HUMAN INTERFACE

The "human interface" concerns the manner in which we use a given piece of equipment, and is often the most important part of the radios we all use. If the design of the radio's controls are intuitively obvious, easy to use, and relatively transparent, the experience of using that radio is greatly enhanced.

Conversely, if you have trouble in remembering how to use the various controls, constantly move your hands around in trying to control the basic parameters of the rig, or have difficulty seeing

the numbers, letters or data, the overall feeling you have of the "box" ends up being not very good.

As an example of what I mean, I have a little DSP-controlled Ten-Tec shortwave receiver (RX-320) that has tons of features available on a "virtual front panel" provided by software running on the PC. I like the radio, but I find it very cumbersome to tune it, adjust its various controls, or have a good feel for where I am in the bands. Mouse interaction is not convenient for me when dealing with a radio. So as a result, I don't use the RX-320 as much as I do my big old Hallicrafters SX-110 receiver. A poor user interface will kill even the best of technology.

This consideration was paramount when I designed the human interface for the Portable PSK station. There are several clever features used in this project and on its front panel. I find them useful during use of the station, and others have commented on the unique approach to dealing with this mode's unusual characteristics.

### The Tuning Display

The first thing one notices when turning on the unit is the apparently random flashing of the 20 little red LED bars contained in the two side-by-side bar graph arrays, as shown in figure 4a. Although the diagram shows a static random pattern of LEDs turned on, the real time display blinks rapidly in a random pattern.

The figure below it in 4b shows the LEDs lighted in a static and orderly manner, which indicates a tuned PSK condition. Let me explain the cause for this orderliness and how it's used by the operator to properly tune a PSK31 signal.

The Spectral Processor receives raw data from the EVM56K modem board containing the phase shift of the received signal. The value of the phase shift corresponds to a number between 0 and 360 degrees, based on a number of factors. The simple answer for now is that the phase indicates a frequency being received.

The constant stream of phase values coming from the modem board are continually output to the bar graph array display indicator on the front panel of the Portable PSK unit.

So just how does this indicate a tuned PSK signal, you ask? Well, we know that a PSK31 uses a "polarity reversal" modulation technique whereby phase reversal of the audio tone is effected when the digital data stream changes from a '1' to a '0' (and, of course, from a '0' to a '1'). At the receiving end, this process results in two tones that are 180-degrees out of phase with each other.

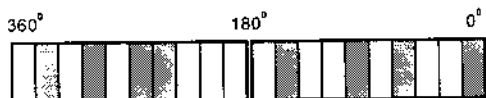

Figure 4a: Random LEDs = untuned PSK

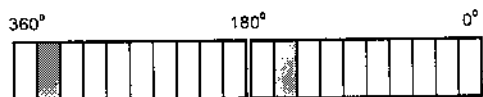

Figure 4b: Matching LEDs = tuned PSK

Recalling that PSK31 modulation and demodulation process uses two tones (hence the characteristic "warble" heard from the receiver), the second tone is also analyzed by the EVM56K modem board. This yields yet another phase value coming across to the Spectral Processor.

When the phase difference of these two tones are displayed on a "radar scope"-type display, it looks as shown in figure 4c.

So finally, given that such a radar scope is difficult to easily and inexpensively put on the front panel of a radio, we do the next best thing ... we unwrap the radar

scope! Visualize snipping the circle of the radar scope at the top

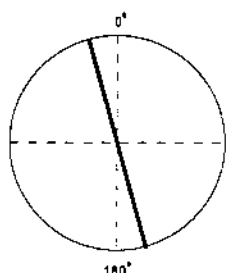

Figure 4c: Conventional 'rada scope' view of tuned PSK signal with its two components

(0-degrees), laying it down flat, and putting twenty LEDs along the line - *voila*, you have our bar graph array tuning device shown in figure 4b!

Whenever a properly tuned PSK31 signal is present, only two LEDs will be on along that linear array. They may be as shown at 342 and 162, or at 324 and 144, or any other LED pair with a 180-degree difference. (Note that our granularity is 18-degrees when using an LED array with 20 positions.)

Another interesting point regarding the tuning characteristic is that when PSK31 stations start and end their transmissions, a single tone is usually transmitted for several seconds. This single tone shows up as a single and constantly illuminated LED that can be adjusted along our "linear" radar scope to be close to the 180-degree mark, as shown in figure 4d. For some reason that I don't

understand, the PSK31 signals are best decoded when the steady carrier is at 180-degrees, and its corresponding out of phase signal is at 0-degrees.

### The Tuning Control

A shaft encoder is used as the

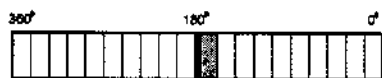

Fig 4d: LED tuning indicator showing a single tone properly

main tuning control on the front panel. This component provides smooth and continuous adjustment of the "center frequency" being received and/or transmitted; hence it modifies the pattern of the LEDs shown on the Tuning Display.

Generally, one tunes a PSK31 radio by adjusting the spectral processing on the audio signal coming through the band pass of the particular radio being used. In our case the PSK-80 and PSK-20 boards from Small Wonder Labs have an audio bandpass of about 2 KHz, which means that an audio signal coming through the demodulation process of that transceiver will be somewhere in the range of 1000 Hz +/- 1000 Hz. Now its not too practical to get to close to the extreme ends of that bandpass filter curve (the slopes of the filters vary), but there can really be a lot of PSK stations contained within that window!

So the shaft encoder instructs

the internal spectral processor to move the center frequency away from the default starting point of 1000 Hz. During this tuning process, there is typical a wild random and bouncing LED pattern in the Tuning Display. But eventually, when a PSK31 signal is encountered the display will tend to "quiet down" and the LEDs will start settling into a pattern that is separated by 180 degrees. And when fine tuning adjustments are made, one is able to carefully move that 180-separated frequency pair indication along the linear array of LEDs. This is rather a fun process all unto itself! And as mentioned, it's best to adjust the display such that the constantly illuminated LED pairs are close to the 0- and 180-degree marks.

Various **options** exist in the configuration of the Portable PSK's tuning mechanism to provide:

- ⇒ variable tuning rates (in order to move faster than 1 Hz increments through the 2 KHz range),
- ⇒ 'memories' that can be called upon to save given locations within the range;
- ⇒ a 'search' algorithm that can automatically find PSK31 signals;
- ⇒ an 'AFC' algorithm that can lock on and track a given PSK31 signal (to compensate for drift).

These and other configurable options can perhaps be described in another installment of this project article.

## "WYHIWYG"

As a derivative of a popular saying, in our "warbling" PSK31 world it is "**What You Hear Is What You Get**". In other words, you often can hear when a PSK transmission is coming into range, and it is helpful to be able to peak the audio within the narrow DSP modem processing window.

An audio level potentiometers is provided on the front panel for this purpose, and a small toggle switch gives it a dual purpose for the pot. Let me describe how these controls are used.

When the Audio switch is down, normal, unprocessed audio from the output of the PSK-xx board is fed into the audio amplification chain. This allows the operator to hear normal, wideband audio coming from the receiver section of the board. The Rx Audio pot adjusts the amplification of this signal, and the operator is able to hear the characteristic PSK warble while he is adjusting the Tuning Control.

Once the warble is tuned to the normal point (which you soon become adept at finding by ear!), the operator can flip the toggle switch up to the PSK Audio position and hear the very, very narrow bandpass filter output of the DSP modem processing. The output of this filter, when amplified, provides a pronounced audio peak in the received signal corresponding to a correctly tuned PSK signal. The Tuning Control and Tuning Display can then be adjusted

to provide correct phase placement of the signal in order to display the data coming across the link.

There is actually another audio level control on the front panel, labeled "Sidetone Audio". This is used as the master volume control for the amplification chain. It has the Morse annunciation tones mixed in and it can usually be set to a comfortable level and then left alone.

Well, I mentioned the next major element of the PSK rig's human interface (the use of Morse code) so let's get into it now.

### **Samuel B. Morse to the Rescue**

An aspect that bugged me in my example of using the computer display of the Ten-Tec DSP receiver was the alternating use of the computer mouse and keyboard. It was distracting and just not intuitive. It wasn't a "radio".

Same too for all the conventional PSK interfaces available today. They're powerful but they just don't look or feel like a radio that I'm used to using. And they certainly aren't very convenient to lug along on my back while climbing the mountain.

So why not the obvious? Why can't we use Morse code to input data instead of typing it on a keyboard? And why can't we listen to Morse code data being played from the speaker? Should be just like listening to the trusty ol' Sierra QRP rig that I've been using for years, right?

Of course the answer is an emphatic YES for each of these situations. There are some obvious challenges (and some not so obvious) that need to be overcome, so let's get into it.

We'll need a basic Morse input and output "engine". There have been numerous articles, projects and kits in recent years describing how to construct Morse keyboards and Morse displays. These projects use a basic software element called a Morse-to-ASCII converter, or an ASCII-to-Morse converter.

ASCII is an acronym that represents the code for printable characters like those displayed on a computer screen or LCD display. It's a common coding scheme for the digital world and it's the kind of data that PSK31 systems send across the RF links. This is because computers have been classically used at both ends of the communications channel. It's a natural!

But it's not natural to interpret these ASCII-coded characters with the human ear. The ear is a good input device for Morse code, especially with our years of CW training between the ears. So the challenge is to use the right converter in our PSK transceiver to translate between the different worlds.

So I obtained and modified some software modules to perform the Morse-ASCII-Morse conversions and put them integrally in place as the primary input and output schemes for data as well



as commands.

**Morse data input** is the easy and obvious design to accommodate. A standard "keyer" software element is needed to accept the paddle as input and then convert the Morse character to its ASCII representation. The data character can then be displayed or sent to the PSK modem for ultimate transmission out the RF link. The Morse keyer output is also echoed through the audio chain as the "sidetone" to enable the operator to easily send with the normal feel of a CW rig.

**Morse control input** is similar to the data input design, except the commands entered are never modulated and sent out the RF link. They are instead used to command the transceiver and configure its memories, modes and states.

At this point it would be good to mention an interesting aspect in the use of Morse for both data and command.

With displayed characters there are all sorts of ways to distinguish data from commands on input, or data from status in output. Displayed characters can be placed in different locations of a screen, different colors can be used, different fonts and sizes can be used ... there indeed are many ways to distinguish data from command/status.

But **Morse audio output** is still Morse code, no matter how you cut it, right? NO! In this PSK transceiver we 'color' the Morse

code in two ways: **speed** and **tone**.

Since the rate of characters going over the link is relatively slow, the Morse input (keyer speed) and Morse output (annunciation) functions are kept at the native slow speed of 10 wpm or so. And the frequency of the sidetone during Morse input, and of the sounded Morse during data reception, are both set somewhat lower (550 Hz). So data = "slow and low".

On the other hand, commands input and status output are distinguished by being sent fast (default of 25 wpm, but configurable), and at a higher pitch (750 Hz). So command/status = "fast and high".

Thus the ol' gray matter between the ears is able to lean back and interpret what's going on. Eyes closed, during the dead of night, or in bright sunlight ... this is indeed a human-friendly interface!

But there still is a curious aspect of using Morse annunciation with a data mode such as PSK. In a perfect world of perfect copy and near errorless transmission and reception, this scheme has potential. But how about on a **noisy link**?!

I must admit that this is problematic when trying to copy Morse code in the head with all sorts of nonsensical characters coming from the speaker. It's actually hard enough trying to read this garbage data on displays, but your brain is able to relatively easily "fill in the

blank", or even just skip over obviously garbled data.

But with garbled Morse annunciated data output, and especially when it comes at a slow rate, it's difficult to put the "big picture" together. In these instances it's best to hope for a good link. We also have a feature built into the modem software that only announces data when there is a solid sync present. In the cases with garbled data, the speaker would remain quiet. So far this seems to have worked pretty well.

### LCD Display

As an assist to viewing the data and frequency settings of the PSK transceiver, an LCD display is provided on the front panel. It shows 2 lines of textual information with 20 characters in each line.

The top line of the display is dedicated for data - received data when receiving, and transmit data was transmitting. It presents the data in a left-to-right movement similar to that seen in a stock ticker tape display. Once scrolled off the left side, data is lost unless logging is enabled to capture the data to a file or to the auxiliary serial port on the back panel.

The bottom line of the display is used to display a variety of information. The left side shows the current mode and state of the internal processing, and to provides a prompt for command input by the operator. The right side is used to display the center frequency of

the transceiver.

### The Rest of the Story

As illustrated in figure 1 back on the first page of this article, the remaining controls and connections on the **front panel** include:

⇒ Tx/Rx Pushbutton - provides a means to manually put the PSK transceiver into transmit mode.

The contents of any unemptied buffer is sent, and then data continues to be sent until the pushbutton is actuated again to put the rig back into receive mode.

⇒ Tx LED - this is illuminated when the PSK transceiver is in transmit mode, either through manual means (Tx/Rx Pushbutton), or automatically if the "VOX" mode is enabled.

⇒ Command/Data Pushbutton - signals the internal I/O Controller to next accept either command or data from the user. The respective command or data state is displayed in the bottom left line of the LCD.

⇒ Do It Pushbutton - This is used to initiate action set up via a previously-issued command. For example, actuating Do It may be used to send the contents of a buffer containing QTH information.

⇒ Key Jack - accepts the paddle as the main data input and control device of the operator.

⇒ Phone Jack - accepts a standard headphone for quiet listening or for external amplification.

As illustrated below in figure 5, the **rear panel** sports the fol-

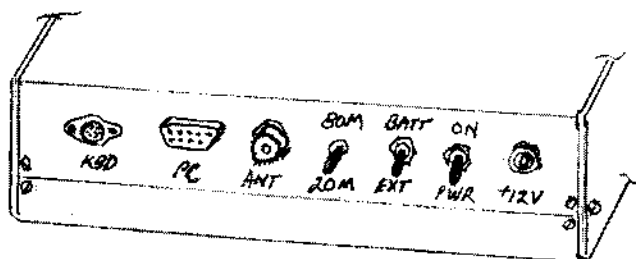

Figure 5: Rear Panel Interface

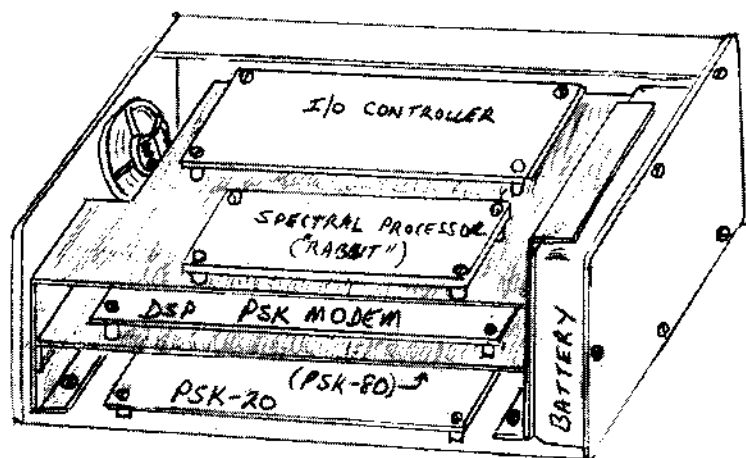

Figure 6: Physical Construction

lowing complement of interfaces.  
 +12V - a 2.1mm coaxial power jack is used to input +12-14.5V DC power source.

Power ON - switches in the selected DC power source.

Batt/Ext - selects either the internal battery or the external DC input as the power source for the PSK transceiver. The battery is charged when the main power switch is off if an external supply is connected.

80/20m - selects the desired transceiver by applying power to it and switching its RF to the rear panel antenna jack.

ANT - the antenna gets plugged into this jack

AUX - This is the auxiliary serial port through which data may optionally be directed. (e.g., for data logging, remote computer control, etc.)

KBD - accepts a standard AT-style PC board as an optional data in-

put means. (There are some attractive miniature keyboards that might even be applicable for field operation.)

### PHYSICAL CONSTRUCTION

Given a pretty strong design requirement of being "portable", I felt compelled to ensure that even the prototype unit was constructed in a small form factor.

At this infant stage, the Portable PSK transceiver consists of five boards that needed to be packed into a small enclosure. Referring to figure 5, I took the approach of creating three layers of circuit boards, using bare copper-clad pc board material as the decks. I was thinking that I might need to make each deck somewhat "RF tight" to reduce the computer's EMI from interfering with the transmitted/received signal (or vice versa), but it turned out to be unnecessary.

The two PSK-xx transceiver boards are located on level 1, the EVM56K DSP board is located on level 2, and the pair of microcontroller boards (the Rabbit Spectral Processor and the 8051 I/O Controller) are contained on level 3.

Tucked along the side of the enclosure is a sealed lead-acid 12 volt battery to provide some amount of off-mains operation. As the project evolves, some boards will combine into one and better economy of power can be realized.

### SCHEMATIC

The I/O Controller Board is the only homebrew circuit board, and even this is relatively straightforward in design, as shown in figure 7. [The schematic is found in the inserted centerfold section]

All of the "smarts" are included in the 8051 microcontroller software. Pushbuttons, LED, serial port and PTT "keyline" are all controlled by basic bit manipulation.

Individual bits also turn on/off the two separate tone generators composed of the 74HC240 inverter gates operating in linear mode as oscillators. These audio waveforms are combined with the amplified PSK data signals at the input of the LM386 amplifier, used to drive a small speaker.

Even though the 8051 processors are relatively garden variety these days, I feel compelled to explain my use of the Dallas Semiconductor version. I've been using the DS5000T device for many years, although it's a bit expensive (~\$30), it provides an excellent developer platform with its flash (nonvolatile) memory and its ability to have new programs downloaded directly to it. No removal for programming via a special programmer, no UV erasure lamps, nothing. And with 8K of memory space, three full parallel I/O ports, PWM generator, A/D port, interrupts, built-in serial port, yada yada ... this makes a super friendly development system. Later, as the design matures, and if the project ever proliferates in

the form of a published design or manufactured rig, the DS5000T's 8051 sourcecode can be easily ported over to a garden variety \$2.95 one-time-programmable 8051 chip.

### **Buttoning it Up for Now**

This is just the first incarnation of a very big and extensible project. There is so much more work and optimization to be done. And most importantly, I need to get on the air a lot more using the rig than I have been able to do during the development of it.

Similarly, there are many natural evolution steps for the technology, features and options. This is an engineers dream box - the flexibility available, and the configurability possible with this design are almost limitless.

One of the more pressing evolutionary upgrades needed is the replacement of the EVM56K DSP board. This evaluation board is no longer available, but there is an equally attractive development board from Analog Devices that should be relatively straightforward to port to. By doing this, more hams will be able to reproduce the design and help move it forward.

Overall, this has been a tremendously exciting design to be working on, and one in a technology area that has the involvement of a growing number of hams and technologists. Being able to provide some "new legs" for a hot technology like PSK31 is truly fun. And actually using it is even bet-

ter!

### **ACKNOWLEDGEMENTS**

I mentioned early on the uncles and many cousins upon whose shoulders I'm standing in being able to do this work. The guys I refer to are Peter Martinez G3PLX, Johan Forrer, KC7WW, and Rob Frohne, KL7NA. Each of these very bright individuals helped and advised me along the way, either through direct contact or in their published works.

Next there is the "PSK Team", as I refer to it, here on the east coast: Dave Benson, NN1G, Skip Teller, KH6TY/4, and Joe Everhart, N2CX. These guys have been instrumental in my mastering of the PSK technology, performing countless hours of online and in-person tests, late night phone calls and frantic email cries for help. They are truly giants in my eyes.

Additionally, Dave Benson has got to be one of the kindest, smartest and most benevolent gentlemen in ham radio today. His work with the QRP community as a supplier (owner of Small Wonder Labs), as a designer and technician, and as a technical leader in the newer technologies is unrivaled.

I've found that there are only very few times when the things align just right in the universe to be called serendipitous (at least for me). But I was able to call upon another of our innovative cousins in the QRP community: Steve

Webber, KD1JV, who had just finished a design that could serve as the exact data conversion engine needed for this Portable PSK transceiver project. His "Deluxe LCD Keyer" had the basic Morse-to-ASCII-to-Morse conversion engines implemented in software and he graciously agreed to share the source code with me for use in this project. I extracted the portions needed and fit it into the I/O Controller board. Thanks a million Steve.

Finally, I applaud the ARRL and its QST staff for pushing forward on PSK31 and encouraging all the experimenters in the ham ranks. Their constant flow of great technology articles and responsive communications goes far beyond the value of the written word. Thank you!

## REFERENCES

1. Diagrams and full color photographs of this project are available on the website of the NJQRP Club, at <http://www.njqrp.org/portablepsk/>

2. PSK-20 Single Board PSK Transceiver is available from Dave Benson, NN1G and Small Wonder Labs, 80 E Robbins Ave, Newington, CT 06111.

3. Peter Martinez, G3PLX, "PSK31: A New Radio-Teletype Mode, QEX, July/August 1999, pp 3-9 (reprinted from RadCom, Dec 1998 and Jan 1999 issues).

4. Don Urbytes, W8LGV, "A PSK31 Tuning Aid," QST, Dec 1999, pp 35-37.

5. Steve Ford, WB8IMY, "PSK31 - Has RTTY's Replacement Arrived?," QST, May 1999, pp 41-44.

6. Steve Ford, WB8IMY, "PSK31 2000," QST May 2000, p 42.

7. Howard "Skip" Teller, KH6TY, and Dave Benson, NN1G, "A Panoramic Transceiving System for PSK31," QST, June 2000, pp 31-37.

8. Dave Benson, NN1G, "The NJ Warbler - a PSK-80 Single Board Transceiver for PSK31," QRP Homebrewer, Summer 2000, pp 15-21.

9. Johan Forrer, KC7WW, "Using the Motorola DSP56002EVM for Amateur Radio DSP Projects," QEX, Aug 1995, pp 14-20.

# QRPp Subscriptions

QRPp is printed 4 times per year with Spring, Summer, Fall and Winter issues. The cost of subscriptions is as follows: US and Canadian addresses: \$15 per year, issues sent first class mail. All DX subscriptions are \$20 per year, issues sent via air mail. To subscribe send your check or money order made out to Jim Cates, NOT NorCal to: Jim Cates, 3241 Eastwood Rd., Sacramento, CA 95821. US Funds only. Subscriptions will start with the first available issue and will not be taken for more than 2 years. Membership in NorCal is free. The subscription fee is only for the journal, QRPP. Note that all articles in QRPP are copyrighted and may not be reprinted in any form without permission of the author. Permission is granted for non-profit club publications of a non-commercial nature to reprint articles as long as the author and QRPP are given proper credit. The articles have not been tested and no guarantee of success is implied. If you build circuits from QRPP, you should use safe practices and know that you assume all risks.

## Back Issues QRPP

**1993 - \$10**

**1994, 95, 96, 97- \$15 per issue**

**1998, 99 - \$20 per issue**

**Shipping & Handling:** US: \$4 for 1 - 3 issues. \$5 for 4 - 7 issues.

**Canada:** \$4 for 1 issue \$5 for 2 - 3 issues \$7 for 4 - 7 issues.

**DX Europe & South America:** \$5 for 1 issue \$7 for 2 - 3 issues \$10 for 4 - 7 issues

**DX Pacific Rim, Australia & New Zealand:** \$5 per issue ordered \$10 for 2 issues \$15 for 3 issues \$20 for 4 issues, etc.

Send Check or Money order in US Funds only to:

**Doug Hendricks  
862 Frank Ave.  
Dos Palos, CA 93620**

**NOTE:** Make Checks Payable to Doug Hendricks NOT NorCal

**QRPp, Journal of the NorCal QRP Club**  
862 Frank Ave.  
Dos Palos, CA 93620

**First Class Mail**



**First Class Mail**  
**U.S. Postage**  
**Paid**  
**Mailed from Zip Code**  
**93620**  
**Permit #72**



# IOWA QRP 10 By Mike Fitzgibbon, NØMF

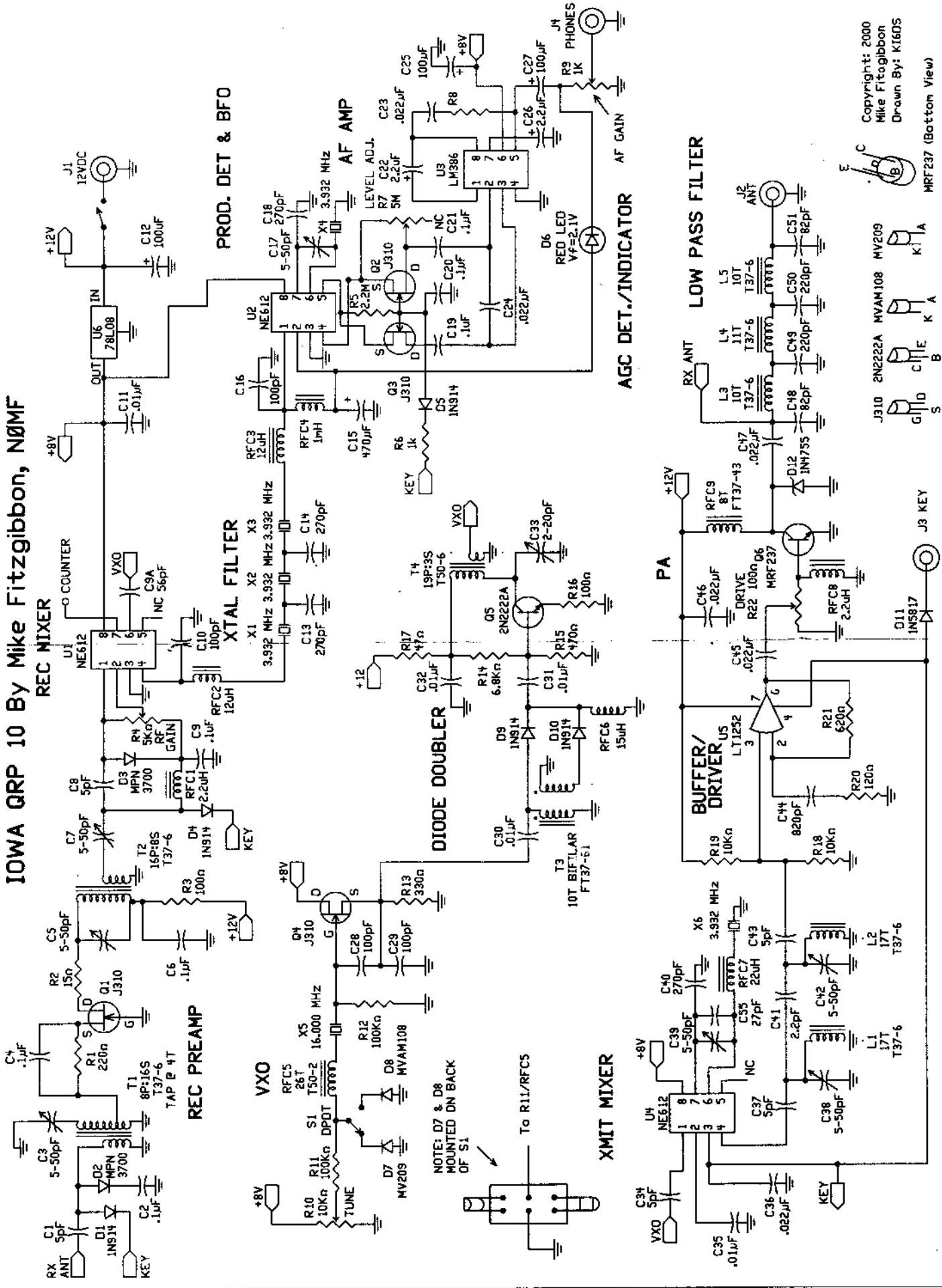

Copyright: 2000  
Mike Fitzgibbon  
Drawn By: K16DS  
MRF237 (Bottom View)

J310 2N2222A MVMAM108 MV209  
G11D S  
C1E B  
K A  
K11A

# An Integrated & Portable PSK31 Station for 80/20 Meters

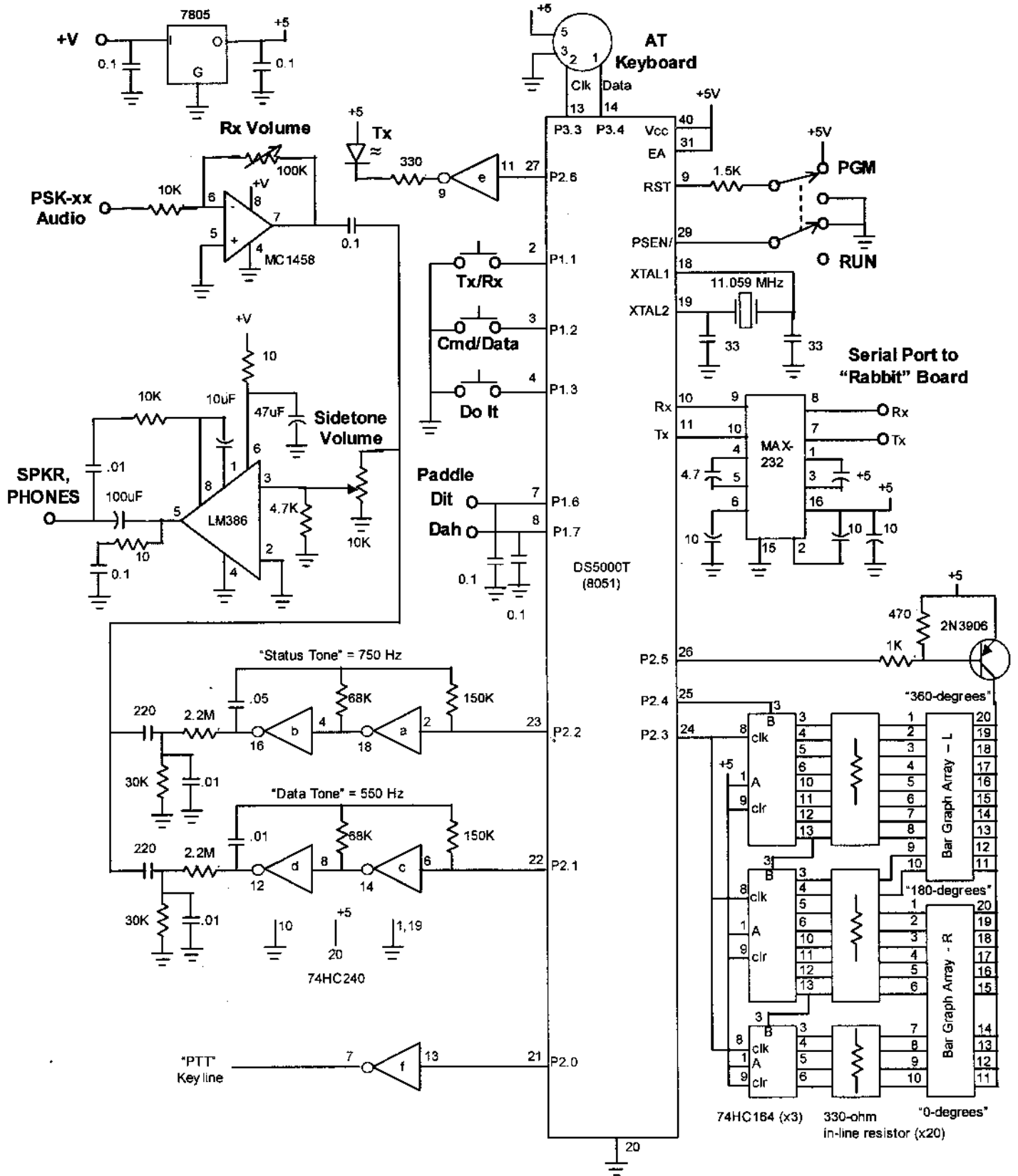

Volume VIII No. 4

Winter 2000

# QRPP

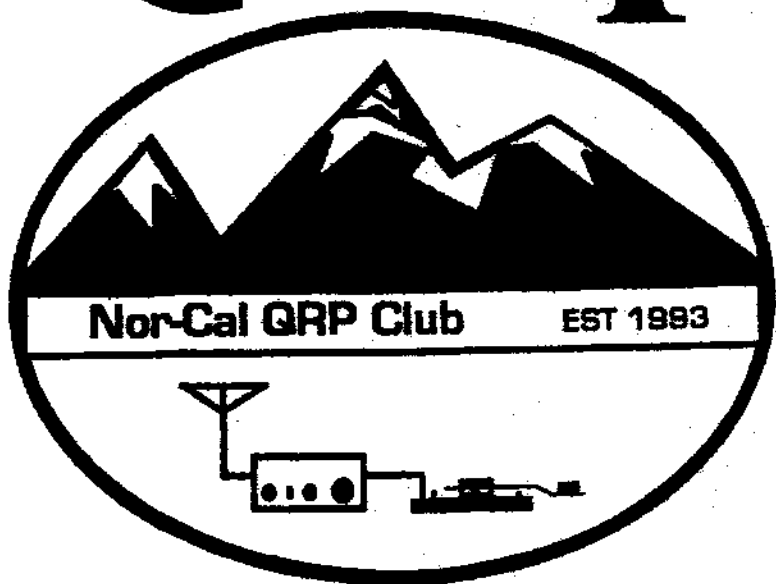

## Winter 2000

Journal of the Northern California QRP Club

## Table of Contents

<b>From the Editor</b> .....	<b>2</b>
Doug Hendricks, KI6DS	
<b>QRP Operating News</b> .....	<b>3</b>
Richard Fisher, KI6SN	
<b>Some Disconnected (but Still Useful!) Thoughts about Amateur Radio Antenna Systems</b> .....	<b>7</b>
James Duffey, KK6MC/5	
<b>The St. Louis Paddle</b> .....	<b>16</b>
Dave Gauding, NF0R & Andy Becker, W0NVMM	
<b>Test Equipment That Doesn't Cost a Mint</b>	
<b>An RF Probe</b> .....	<b>26</b>
Graham Firth, G3MFJ	
<b>Test Equipment That Doesn't Cost a Mint</b>	
<b>A Simple and Inexpensive Audio Signal Source</b> .....	<b>27</b>
Tony Fishpool, G4WIF	
<b>K20 CW/Keyboard Keyer</b> .....	<b>29</b>
Steve Elliot, K1EL	
<b>The Rochdale Mini QRP Convention 2000</b> .....	<b>37</b>
Dick Pascoe, G0BPS	
<b>QRP to the Field 2000</b> .....	<b>40</b>
Jan Medley, N0QT	
<b>The Epiphyte 3, A 75 Meter SSB Transceiver</b> .....	<b>47</b>
Derry Spittle, VE7QK	
<b>SMK-1, Rock Bound No More</b> .....	<b>59</b>
Wayne McFee, NB6M	

### From the Editor

Doug Hendricks, KI6DS

Holiday greetings to all of you. This is another good issue of QRPP with lots of projects to build. We have several familiar authors, and a new one, Steve Elliott, K1EL. You will also note that the format of QRPP has changed a little. We have gone to one column, which will make the articles easier to read. Graham Firth, G3MFJ made the suggestion. Speaking of Graham, I am pleased to announce a new QRPP feature column, Test Equipment That Doesn't Cost a Mint. Graham and Tony Fishpool, G4WIF gave a wonderful presentation on that subject at Pacificon 2000, and we have decided to make it a regular column for QRPP. Each issue will feature a simple piece of test gear that you can build for your shack. Hopefully you will learn as you build. With that, on to the issue. Enjoy, Doug, KI6DS

## QRP Operating News

By Richard Fisher, K16SN  
1940 Wetherly Way  
Riverside, CA 92506  
K16SN@yahoo.com

### That warm QRP glow

**Bruce Hopkins, KL7H**, writes from the Bahamas that he "just had to tell you about a simple QSO that I had on 40 meters recently.

Central Bahamas to New York with 2 watts! No big deal, right? But wait, there's more.

Mike Branca, W3IRZ, kitted a limited number of transmitter kits for the North Georgia QRP Club called the NoGa-80. I was very fortunate to be able to get one. Mike was only able to make a few kits because most of the parts came out of peoples junque boxes, you see, this is a two tube 2 watt transmitter. It uses a 12V wallwart for the filaments, and rectifies and filters the 115-volts AC house voltage to come up with 150-volts DC for the B+. Mike says just about any audio or transmitting pentode will work with perhaps a few small parts adjustments. My rig uses two "Mighty 6AR5" firebottles in parallel to deliver approximately 2 watts to the antenna.

A simple mod to the coil turned my rig into a two-bander, 80/40. I built it on a small cedar box that some Alaskan smoked salmon came in. Mike's original version was built in an Altoids tin with the power supply in a separate plastic container. This kind of project lends itself to creative packaging. I spent a couple of very happy days putting this little jewel together, and it has rekindled my glowbug juices. This is fun! If it sounds half as nice on the receive end as it does in my monitor receiver, I am pleased.

Now to put that 80/40 regen receiver together. Where's my kerosene lamp? I will be on most evenings between 9 p.m. and 11 p.m. Eastern time zone. My main operating frequencies will be 7.040 or 7.050 and 3.579. Mike has been kind enough to let me reproduce this circuit on my webpage so others might enjoy this rig. I will also put up the circuit for his nifty 12V two tube regen receiver that might make a good mate.

I have not built the receiver yet but once parts arrive on the mailboat, I will be giving it a try. If you have any leanings toward "hollow state," this is fun! Just remember, that you will be dealing with possibly "Lethal Voltages", so if you are not competent with this, do find an Elmer that is to keep you safe! The web page should be up by the time you read this. Look under GlowBug on my site below. "Keep-ern-Glowing."  
(The KL7H website is: <http://www.qsl.net/k17h>)

### Milliwatting the SP

**Randy Foltz, K7TQ**, writes from Moscow, ID that he "worked the October Spartan Sprint at 100 mW with a K2 and a GAP Titan antenna. From here in ID I made only 6 contacts, but they were worth it! The farthest was

with Carter, N3AO, in PA for 21,090 miles per watt. Other 20 meter contacts were with Doc, K0EVZ, in ND for 7,660 miles per watt, Mert, W0UFO, in MN for 11,510 miles per watt, and Brian, K7RE, in AZ for 9,420 miles per watt.

Before the contest was over I made two 40 m contacts. One with Russ, AA7QU, for 3,230 mpw and one with Wes, W7ZOI, for 2,900 mpw. Each of these operators have great ears! At 100 mW you don't work everyone you hear. It seemed that stations on the edges of the activity had better success. Tonight increased my state total to 8 with 2 provinces since the first of September using the GAP and 100 mW. Over the weekend I worked JE1REU on 10 m for 50,200 miles per watt. He gave me a 559, but maybe he was just generous. At least I didn't have to repeat things. It doesn't take beams on tall towers to work a few with 100 mW. (But it helps!)

### **A charged-up QRPer**

**Jim Hale, KJ5TF**, writes that "the last couple years I had a blast island hopping in Arkansas.

Yes! We have islands on lakes and rivers. In activating 3 of them for the US/VE Islands Awards program, I've had some fun carting batteries around. I found that for a short afternoon of CQ'ing on the beach at 750mW I could take one 13v nicad battery pack along and that was enough. If I thought 2w was going to be needed, I'd take a second battery pack. I found some surplus 2AH "C" cell nicads, and re-soldered the 10 cells to a pack. Using a wire stinger on a Black Widow 20ft pole, with 2 raised radials on 20M I had no problem making contacts all afternoon. Many of the contacts went into "QRP Limbo" as I lowered my power to double digit mW's, working state after state.

If a person is camping or hiking and wants to take a solar panel along, that's great. Those roll up kinds are pricey. I'd look at those dash board solar battery chargers. I've seen them in JC Whitney, and other places on special around \$20. It's been years though. Sure they are not 5w, but even a fraction of an amp can re-charge some 2AH "C" cell batteries in time. You could look for the hottest charger of that type, and buy two when they go on special. If you've never tried mW'ing while portable, or mobile I can tell you it really works!

When the 49er rigs first came out, I used to take my 250mW 40M 49er mobile with me. I could make several contacts in evenings with a 40M Hamstick! You could also use a QRP rig that works ok on less than 12v. The 49er ran fine on a 9v btry. One of those dashboard solar chargers might charge up 9v worth of "C" cell nicads FB! I have some pictures of my Slate Gap island expedition on my webpage if you'd like to look, please do."

### **QRP fun on 'Friday the 13<sup>th</sup>'**

**Paul Christensen, W9AC**, writes from Jacksonville, FL that on a weekend in mid-October he "began planning for a short camping trip with my two daughters. Since they both like Goldhead State Park near Gainesville, FL, we decided to travel from our home in Jacksonville to the camp site late yesterday morning.

After pitching our small three-man tent I immediately began assembling my W6MMA/St. Louis Vertical. I carry enough No. 22 AWG wire to place anywhere from six to ten radials along the ground. The vertical was placed far enough away from the camp site and blended in nicely with the pine trees. I tuned the vertical for 40-meter CW using an Autek Research analyzer and completed the job in less than five minutes.

Everything was going along fine until I began critically listening with my Red Hot 40 transceiver. Every station sounded as if it was drifting and had PLL problems. Next, I tried my Norcal Sierra and Norcal 40A. Not nearly as bad, but when I keyed the Norcal 40A, my sidetone audio sounded raspy. Could it be my power source? Sure enough, my trusted 2AH gell-cell had gone soft after four years. Measured terminal voltage after charging was only 11 volts and was sagging fast. After all, it was Friday the Thirteenth and the moon was full!

Without another portable power source, I remembered that my Plymouth van had a 12-volt outlet at the rear of the van. Yes, another automobile that requires that the ignition switch be turned in the 'accessory' position in order to deliver power to the jack. All I can figure is that at some point in the past 10 years, a products - liability action commenced, an auto manufacturer lost the case, and now the rest of us have to live with this wonderful inconvenience, or make the change to the cars ourselves.

Anyway, I then plugged the Red Hot 40 into the van lighter jack, keyed the rig and I was finally on the air. But something was still amiss - the RH40 was nearly deaf on 40-meters. I need to investigate why.

After switching to the Norcals, the band was full of stateside and DX signals. The Norcal 40A still amazed me even though it's almost five years old.

I now own six QRP transceivers, including one completely homebrew, and the Norcal 40A is without a doubt my favorite to operate. The audio fidelity is great, I added the ABX filter, 10-turn pot, KC-1 and brought out all controls to the front panel.

I am anxiously awaiting the K1 from Elecraft, because the Norcal-40A for 40-meter QRP operation is about as Zen as it gets! I sure hope the K1 has the QSK speed of the SST!

About 9 p.m., I called F5PLC, and had a great ragchew QSO with him running only 2-watts into the W6MMA/SLV. He was absolutely floored that I was running this camp site setup and engaging in a transatlantic QSO with him with only a couple watts into a portable antenna on 40-meters. This is the stuff that makes this stuff all worthwhile!

I just finished putting all the camping gear back into the closet and

began preparing the shop bench for the Elecraft K1 kit! I'm sure it's gonna' be another winner!

### **QRP Sweepstakes success**

**Gary Phillips, KA9NZI**, writes from Marengo, IL that while he's "certainly not a top-notch contester, I felt pretty good about my November Sweepstakes 2000 results until I saw some of the others being posted (on QRP-L).

My excuses: I've avoided the high profile contests for years, scared off by QRM and the machine-gun code speeds I set these goals for myself:

Operate at least 10 hours, which is more than I would probably have done as a non-bull. Spend at least 15 minutes of each hour calling CQ.

As long as I was doing that, keep it up until I broke the 100 QSO mark and could get the pin.

Fill in my missing states for this QTH: AK, ND, DE, RI, SC, and NY. (NY? Yep, no I don't know why.)

Within that framework, I guess I did OK. Achieved the first two, and I did get AK and NY 2-way QRP.

Here are the summarized statistics: Running a TS450S cranked back to 4 watts out, G5RV antenna at a nominal 40 feet (but it passes through a maple tree.)

**Total hours:** 13

**Total QSOs:** 110

**Sections:** 42

**Score:** 9240 (if they don't throw some out for bad copy).

I did call CQ much more than I normally would, but with few takers. . . . QRP stations in my log were as follows: VE6BIR/7, KL7AC, K6MI, W0AH, KI0II, K7ED, K6EIL, K7QO, K7RI, K5NZ, W2EB, K0FRP."



# **Some Disconnected (but Still Useful) Thoughts about Amateur Radio Antenna Systems**

by James R. Duffey, KK6MC/5  
30 Casa Loma Road  
Cedar Crest, NM 87008

I have been a ham for more than 30 years. Antennas have always been a passion for me. There are few areas in the typical amateur radio installation that can offer so much improvement to overall station performance than attention to the antenna system can provide. I am a firm believer in home-brew antennas. They are far less expensive than the commercial variety and can be built with better performance. Contacts made with a homemade antenna offer a high degree of satisfaction and build confidence in one's technical ability. When I say antenna system I am referring to more than just the antenna, but rather the antenna, feed line, any tuner that is required and any balun matching device.

## **What can I Do to Improve My Antenna Performance?**

There are some things that can be done to improve antenna performance. If you can't trade that old ground mounted trap vertical for a 5-element monobander at 100 feet, you can still improve your signal. Consider the following:

### **Raise your antenna**

Both verticals and dipoles will improve significantly with a gain in height. This is particularly true in urban areas where a low antenna can interact with a great deal of conducting material that can degrade its performance. While a half wavelength is generally considered the minimum height for an effective DX antenna, even increasing the height 5 to 10 feet can make a marked improvement in many cases. Raising a vertical from ground level to roof level and providing 4 radials per band will make a big difference in performance.

### **Get Rid of Feedline Radiation**

Feedline radiation can distort radiation patterns, change the antenna polarization vector, reduce the effective height of the antenna, and result in unnecessary losses. The most common cause of feedline radiation is a transition from a balanced antenna or feedline to an unbalanced feedline or antenna. Examples of such terminations include; a dipole fed with coaxial cable, a vertical fed with balanced feeder and the popular "j-pole" antenna (which makes the mistake twice!). The way to prevent this problem is to properly make the transition. The proper way to make the transition is with a balanced to unbalanced transformer, commonly called a balun.

An RF choke on the braid of coax will give the same results. An RF Choke or balun can be made simply by coiling the coaxial cable according to instructions given in both the Handbook and Antenna Book. Alternatively, a simple balun can be made by winding 10 to 12 turns of RG-58 on a ferrite core of low permeability. Sevick's book on baluns gives full details. Many hams use a W2DU balun that consists of the feedline threaded through a dozen or so ferrite beads. Since the beads must be high permeability the losses are generally higher with this type of balun, but it is perfectly acceptable at HF, particularly for QRP use.

There is an excellent reference to air wound coaxial choke baluns on the web at:

<http://www.berkshire.net/~robbins/technote/airbalun.html>

The simplest way to feed a dipole is with a balanced feeder and a tuner. This is a simple and effective antenna. When comparing feedlines the loss of the tuner must be included, which for resonant antennas brings the total loss roughly equal to that of a coax fed antenna. This antenna system can be used on all bands though, while the coaxial fed antenna will have significant losses on bands other than odd harmonics.

A vertical can also gain from an RF choke. If the feedline is an odd multiple of a wavelength long, the radials and the feedline can combine to form an antenna. Coiling the coax at the feed point according to the figures in the handbook should help this.

### **Change the feedline to a lower loss feedline**

While buying premium feedline may seem expensive, it is probably one of the areas where a ham can get the best bang for his buck. A commonly accepted figure for "acceptable loss" is 1 dB. If one is willing to accept 1dB feedline loss in a typical 66 ft feedline run: then zip cord is acceptable at the broadcast band, RG-174 at 160 M, RG-58 to 20 M, 8X to 17M, RG-213 to 10 M, and ladder line to well past 30 MHz. To paraphrase Ev Dirksen: "a dB here and a dB there and pretty soon it starts to add up to big losses". If 0.5 dB is the criteria, then zip cord and RG-174 are out of the picture, RG-58 is good through 80 M, 8X to 40 M, RG 213 to 20 M, and of course the ladder line is still below 0.5 dB at 10 M. The difference in cost between 100 ft of RG-58 and RG-213 is \$23, which seems like little to pay for a 0.5 dB gain, at least if one does not have the checkbook in hand. Buy good quality feedline; much of the cut-rate stuff sold for CBers is next to worthless. I am often asked if the coax used for local area networks can be used to feed antennas. The answer is yes. Be careful about "taps" which are sometimes used to make contacts to the cable, and beware that the jacket might discolor in the weather, but that will not effect electrical performance.

I have made my own balanced feeder and am of the opinion that is

more trouble than it is worth. The 450-Ohm ladder line is \$15 to \$20 per 100 feet and is well worth it in reducing frustration. I don't get nearly as many comments about my choice of insulator materials though.

### **Improve your ground**

If you are using a vertical, increasing the number of radials will have the biggest impact on the performance. For ground mounted radials, the length need not be resonant. In general, the more radials you have the better off you will be. Length is of secondary importance, but the more radials you have, the longer they should be. A good rule of thumb is that the separation at the end of the radials should be 0.05 to 0.1 wavelengths. Try to buy copper wire surplus by the pound. The wire diameter doesn't make much difference. Rental of a power lawn edger helps a great deal.

### **Use your dipole as a vertical at low bands**

A dipole on 160 M, 80 M, and 40 M often cannot be erected at effective heights, greater than a half wavelength, for DX. One way to turn these antennas into better low-angle radiators is to tie the feedline together and feed it as a vertical against a few radials. This gives you a simple top fed vertical.

### **Can I use PVC for Antenna Insulators?**

Yes.

PVC is a mediocre, but still acceptable, dielectric. It has a low softening point though, so excessive losses can cause problems. Don't use PVC for coil forms in high loss, high current applications, but for QRP use they are perfectly acceptable as trap forms, coil forms, center insulators and end insulators. PVC was widely used in antenna applications through the late 70s without anybody questioning it. Even several commercial products used PVC. This is not surprising since PVC is probably one of the widest available antenna materials with every hardware store carrying it in one form or another. In the late 70s QST carried a picture of a coil that was wound on PVC that had melted. This started the hue and cry against PVC that still exists today. However, the coil was long, of small diameter, wound with small diameter wire, and used as a base-loading coil for a short 160 M antenna. The coil had excessive losses, which in turn lead to heating of the coil and form which lead to the meltdown. For most applications, PVC is perfectly acceptable. A recent Antenna Compendium carried an article on mobile antennas where the author found that a coil wound on PVC had a quality or Q factor only 10% less than a similar air wound coil.

I prefer the PVC sold as electrical conduit. It is gray in color and available in most building supply stores. It is UV resistant and is designed to stand up to the weather. Plumbing PVC is usually resistant to UV, but not always. One of the urban legends floating around the ham world is that one

can verify the effectiveness of a given PVC sample by nuking it in a microwave. While this is a fun experiment (along with microwaving raisins and frozen cockroaches), it will tell you little about the dielectric losses at HF. The dielectric constant can change significantly from 2.4 GHz to 7 MHz, and go either up or down. However, if it will make you sleep better at night go ahead and do it.

### **Don't Use End Insulators**

Following a suggestion in Moxon, I have stopped using end insulators. I simply tie a sheet bend or double sheet bend (see a Boy Scout or Girl Scout Handbook for details) using the wire and support line. I use the smallest diameter line I can get away with to support the antenna. Depending on what the sporting goods store has in stock, this is usually 50 to 100 pound test nylon monofilament sold for fishing reels. This is not an optimum material for end ropes though. I have found at my altitude, 7000 ft ASL, it gradually loses strength and has about half the breaking strength after 3 years in the sun. My antennas seldom last more than 3 years, as I am off to try something new in shorter time than that. If my antenna comes down I consider that a sign that I should put up a new one!

### **Add a Resistor across the Antenna Feed Point**

If the feed point is open such as in a dipole or vertical, consider adding a high value resistor across the feed point. For a low impedance antennas such as a dipole or vertical a 20 kOhm or higher resistor will do. For a high impedance antenna, use a 100 kOhm or higher resistor. This resistor is handy for evaluating feedline integrity; just put an Ohmmeter across the feed point in the shack. If it reads anything other than the resistor value, you have a feedline problem. The resistor also puts both sides of the antenna at DC ground, which can help eliminate precipitation static. The power dissipated in the resistor will be minimum if it is large (100 times or so) compared to the feedpoint impedance of the antenna.

### **Don't Use Pulleys!**

I have stopped using pulleys to raise the ends of antennas on my masts. I use instead the ceramic insulators used by electricians to fasten the electrical drop wire to houses. These look like half eggs with a hole in them and a screw attached to the flattened end. I put the rope (called a halyard) through this hole and use it as a pulley. The wires coming into the house are much heavier than any wire antenna I have erected so I know it will hold. the finish is smooth so the rope slides freely. Best of all the thing can't jam, rust, or disintegrate in the sun. They too, are commonly available at building supply houses. While you are at it, install two pairs of halyards in case one breaks. Plan ahead.

### **Buy a Heavy Duty Soldering Iron**

That 25 or 35 watt soldering iron you used to assemble the latest NorCal kit won't cut the mustard when trying to solder outside in the wind even on a warm summer day. Forget about it in the middle of winter with a cold north wind and temperatures in the teens. At least a 100-watt iron is needed for antenna work outside. Radio Shack sells one that is almost adequate; the old American Beauty Soldering irons sold to plumbers are much better if you can find one. Many people use soldering guns and they are widely available. I have always found the tips to be fussy and need tightening at the most inconvenient times. A very long extension cord is also very useful.

### **Antenna Supplies for the Building Supply Store**

Your local Home depot, Builders Square, Lowe's, or local hardware store can provide you with many supplies useful for antennas. The cost may be higher than you would pay elsewhere, but when you come home on Friday evening and need to repair the antenna for Sweepstakes the next day, the convenience is worth the price. I have found the following items at hardware/building supply stores to be useful in my antenna work: wire (this is one case where the building supply store may be cheaper), ground rods, clamps for ground clamps, wire nuts, NoAlOx/Penetrox compound for joining aluminum tubing, electrical tape (get Scotch 33), liquid coat for taped joints, Teflon tape, plumbers strap (sometimes this is available in copper), electrical house drop insulators to use instead of pulleys (see above), pulleys (in case you didn't read above), PVC pipe and fittings, wood for masts, steel tubing for masts, a few selected sizes of aluminum tubing (usually very expensive), stainless steel hardware, U-Clamps, hose clamps, cable ties (get UV proof ones), solder, soldering irons, epoxy, silicone caulk, and telephone interference filters. I am sure that I have left some things out. Avoid the temptation to buy 300-Ohm twin lead or RG-59 TV coax at the building supply store. It usually is of poor quality. For emergency feedlines, Radio Shack is a better choice, but still not the best. Any port in a storm!

### **Some Words About Antenna Tuners**

I acquired my first antenna tuner in 1965 as a novice, WN0MWN. My dad, now WA0OML, bought it for me after I got a "pink slip" from the Grand Island NE FCC monitoring station for radiating a second harmonic of my 80 M CW signal on 40 M. He had read that it might reduce harmonics. Properly tuning the grid would have been a better solution, but man is always enamored with technology. It was a Millen Transmatch Jr. I still have it. It is a thing of beauty. The wire is silver plated as is the inductor, the capacitors have ceramic endplates with velvety smooth double ball bearings, there is a heavy duty ceramic switch with silver plated contacts, and the chassis is heavy copper plated steel. It is most useful on coaxial fed antennas, although one must avoid the temptation to load up on a

band where feedline losses are high.

The Millen is a classical Transmatch Tee match. It is worthwhile obtaining one if you can. It is much the better tuner than any Tee match on the market today.

If you feed balanced feeders, the Johnson Matchbox and Matchbox Jr. from the same era are worth acquiring. They have similar construction to the Millen and are still very useful in a modern shack.

If you are purchasing a tuner new, the Z-Match is as good a QRP tuner as any. You can also home-brew one from plans in Antenna Compendium Vol.5.

Besides the Z-Match an "ell" match is a good home-brew project. With only two components, a capacitor and inductor, it has low losses and will match a wide range of loads.

### **Keep Good Records**

Whenever I put up a new antenna, I always record the configuration and SWR (or impedance) plots in my logbook. I suggest you do the same. Then if you think you are having antenna trouble you can check the readings you have with the readings when the antenna is new. I also record the type of wire I use, and any other facts that seem pertinent at the time. This also gives you a good idea of whether or not your new antenna is performing up to snuff by comparing the QSOs before and after the new antenna is erected. Most hams will agree that newly erected antennas work best. The test of time is often not so kind.

### **I Want to Build an Antenna, Which One Should I Build?**

The antenna books and magazines are full of antenna designs. It is sometimes difficult to choose. I offer the following suggestions. They are antennas that are simple to build, easy to get going with a minimum of test equipment, perform well and are easy to understand.

### **HF Single Band**

Either a dipole erected as a flat top or inverted vee is the choice here. Cut it to the dimensions given in the handbook. Measure the SWR. If the SWR minimum is below where you want it, cut a bit off. If it is above where you want it, add a bit of wire. Don't worry about SWRs 2:1 or less. If you are compulsive or retentive don't worry about SWRs below 1.5:1. This antenna works best at heights above a half wavelength, but erected at any height and fed with low loss feedline it will reward you with lots of contacts. The inverted Vee is probably the easiest way to get height. Remember to use a coiled coaxial cable balun at the feed point.

### **HF Multiple Bands**

For this use, I suggest parallel dipoles. Dipoles for harmonically related bands are fed from a common point. Interaction between dipoles can

be minimized by keeping the ends apart. Dropping the ends perpendicular to the antenna by a foot or more is usually effective. Again, use a coaxial cable choke at the feed point

### **HF Vertical**

Single band verticals are more difficult to fabricate than dipoles. However, quarter wave verticals with multiple radials supported from a push up fiberglass mast such as the SD-20, Black Widow, or DK9 pole will work well. A coax choke will help here, as will lots of radials. This is a good candidate for a stealth antenna as it can be raised and lowered readily as needed.

### **VHF Omnidirectional**

The coat hanger special can be built for less than \$3 and will perform as well as any commercial antenna. It is a quarter wave ground plane. Buy a SO-239. Go to Radio Shack if you need to. Cut five lengths of 12-gauge wire to 19.5 inches. Solder one length to the center conductor of the connector. Solder the other four to the mounting holes. Droop them about 45 degrees. Feed with RG-213 or better. This can be mounted by taping the feedline next to the connector to a mast. You can use this indoors as well. Locate it in front of a window. This antenna will blow the pants off a rubber duck. I use THHN wire intended for house wiring. It will start to look a bit ragged if left outdoors for a while, but the performance will not be affected. It is easily replaced or straightened in any case.

### **VHF/UHF Gain**

There are two choices here. The venerable Quagi antenna is a long boom (14 ft) that can be constructed from wood, copper wire and small diameter tubing. It has been a handbook mainstay for 20 years. The performance is not as good as more modern VHF Yagis that have been computer optimized, but it is within a dB or two of the optimum gain for its boom length. When built with reasonable care to dimensions they work without tuning. A balun at the feed point should be used. Either coiled coax or a W2DU style balun should work well here.

Kent Brittain has designed a number of Yagis that can be built with wood, copper wire and aluminum tubing. I have built several and they work quite well. The gain is within a dB of optimum for the boom length. No balun is needed as an unbalanced feed is used. These plans were recently published in CQ's VHF magazine and are also available on the web at:

<http://www.clarc.org/Articles/uhf.htm>

**Hams with One or More Home-brew Antennas Under Their Belt Might Want to Try One of These**

Loops (either vertical or horizontal)  
Two element Yagis (wire or tubing)  
Center fed Zepp  
Optimized Yagis for VHF/UHF  
Long Wires (Point them in the right direction)  
Phased Vertical Arrays (Read the antenna book chapter on this first!)

### **Antennas for the Beginner to Avoid**

I am sure that I will get some flack for this list, but here I go anyway. Those with opposing views can give a talk at next year's Pacificon. See Doug.

Doug may even have opposing views. Many hams have good experiences with the antennas below, but I think there are better choices for the beginner to try. If you must use one of these antennas, try them after you have erected several antennas.

### **Off Center Fed Antennas, Windom or Otherwise**

These can have problems with feedline radiation. This can lead to noise, poor performance, unpredictable radiation patterns, and difficulties in measuring basic antenna parameters such as SWR.

### **The G5RV (at least the version with coax feed)**

This is a popular antenna and performs well when used as intended. As a multiple band antenna it can have excessive feedline losses. It will seldom work on multiple bands without a tuner in which case you are better off with a center fed Zepp, that is a doublet with balanced feeder all the way to the tuner.

### **The W8JK**

One of the first closely spaced beams, this antenna can perform well. However, it has a very low radiation resistance and unless carefully constructed it will have high losses. Even if carefully constructed it has small bandwidth and tuning can be critical.

### **End Fed Random Length Wire**

When fed right these can be excellent performers. However, they often require special attention to eliminate RF in the shack and can be frustrating for the beginner to get going.

### **Any Commercial Antenna**

Build your own. Learn. Enough said. OK?

### **Some Good Antenna References**

In these days of rapidly expanding technical information available over the Internet, I still find comfort in my technical books. In reviewing the



various reflectors on the net, including QRP-L, I often run across questions that the asker could have answered with a quick reference to **The ARRL Handbook for Radio Amateurs** or to **The ARRL Antenna Book**. Therefore, I recommend that any amateur acquire these two references before pursuing others. You needn't purchase these books outright, although they are good value as far as technical references go. Most libraries have copies of the Handbook, and larger libraries have copies of the antenna book. If you can't find either of these at the local library, your librarian should be able to obtain either one through interlibrary loan. While you are doing this, tell the librarian that no modern library should be without these two references.

Antenna technology changes slowly. Therefore, used editions of either book are still useful. Look for used copies of either at hamfests. The handbook is published yearly, while the Antenna Book is updated occasionally. The current edition of the antenna book is 19. I think that some of the earlier editions of the Antenna Book have more information that is useful to the typical ham than the latest edition contains, but that is another issue.

After purchasing and thoroughly digesting the above two references I would recommend **HF Antennas for All Locations** by Moxon, published by the Radio Society of Great Britain. It is available from the ARRL in the United States. Moxon takes an unconventional approach to antennas and has information that is available no here else. I would caution against taking everything Moxon says at face value, but the book is very useful.

If you are technical in nature, I recommend **Antennas** by John Kraus, W8JK. This book is written for a Junior/Senior level course in antennas and uses calculus, but much of it is accessible to those with knowledge of High School Algebra. Kraus is a true pioneer in antennas and electromagnetics, both in the amateur and in professional areas. He was the first to realize the importance of closely spaced elements for gain, which resulted in the W8JK antenna; he invented the helix and corner reflector antennas as well.

I find the **Antenna Compendium** series, now in Volume 6, to be very useful and a gold mine of ideas. I have not seen Volume 6, but all of the volumes are still in print, including Volume 1 nearly 15 years after its introduction; a testament to the quality of any technical book.

If you are into the low bands, 160 M, 80 M, and 40 M, the antenna sections of **Low Band Dxing** by John deVoldere, ON4UN, is excellent reading.

A classic for vertical antenna enthusiasts is **The Amateur Radio Vertical Antenna Handbook** by Capt. Paul H. Lee USN (ret), N6PL. This book has been in and out of print since its introduction as a series of articles in CQ magazine in the mid 60s. Most of the information cannot be found elsewhere and Lee has an excellent discussion of the ground requirements for vertical antennas.

The subject of baluns is treated exhaustively in Jerry Sevick's "Build-

**ing and Using Baluns and Ununs - Practical Designs for the Experimenter"** published by CQ. Sevick is W2FMI and presents balun designs for almost every application.

The now defunct **Ham Radio** magazine reserved its May issue exclusively for antenna articles, and it published some gems in its 23 year life. If you see a stack of used Ham Radio magazines at a hamfest it is worth digging through them to find the May issues if you don't want to buy the whole lot (which you should).

An Internet resource as valuable as many of the books above is the web site of L. B. Cebick, W4RNL located at:

**<http://www.cebik.com/>**

The site is chock full of good antenna ideas. L. B. has particularly good articles there on vertical antennas and the grounds that they require. The page is also a must for anybody doing antenna modeling on a computer. L. B. has also been kind enough to put many of his antenna articles that first appeared in **Communications Quarterly, Low Down, Ten-Ten News, and The National Contest Journal** at the site. A must visit for those with Internet access.

### **Closing Comments**

I hope that you find some of these disjointed ideas useful. I find antenna building one of the most rewarding aspects of the amateur radio hobby. It is a vast subject and I hope that I have helped you to think in new directions with some of these ideas.

### **The St. Louis Paddle**

**by Dave Gauding, NF0R  
nf0r@slacc.com**

**&**

**Andy Becker, W0NVM  
arb@bbs.galilei.com**

In early 2000, K0FF sent along a small collection of homebrew keys and paddles for show & tell at a monthly St. Louis QRP Society meeting. Now retired near historic Hannibal, Missouri, George Dowell's finely crafted projects are always well-received. One single-lever paddle was constructed inside a 1/4 inch stereo plug and quite distinctive. It caught everyone's attention immediately.

The creative design featured externally adjustable contacts but was still suitable for the rigors of portable or trailside operations. Aside from being slim and compact the most important characteristic was performance. It handled as good as it looked.

Unfortunately, old-time lever switches or relays with thin tempered leaves

are critical for duplicating KOFF's very special paddle. These days such devices are in short supply and it can be difficult finding a number of identical units for kitting purposes. Finally, shop tools and the ability to use them properly are required.

A comparable design based upon readily available components was the logical alternative. We started the project with a clean sheet of paper. Fellow SLQS members routinely tested and critiqued the prototypes at five consecutive monthly meetings. Now only simple hand tools and basic soldering technique are required to homebrew this accessory.

The St. Louis Paddle can be plugged into four different applications: separate keyer, custom mounting base, front panel of a transceiver, or a custom cable assembly serving a separate keyer or transceiver.

A special adjustment feature was inspired by NB6M. He had designed a single-lever paddle with a passive tensioning system which met our needs perfectly. That homebrew project is currently featured on NorCal's web page. KI6DS also adopted the innovation when he designed the Iambic Paddle/TiCK Keyer Kit for the Ft. Smith QRP Club.

Homebrewers can collect the few off-the-shelf parts needed for a paddle and build it easily from this article. Have fun and as always modifications and improvements are officially encouraged.

### **Materials**

- 1 ea. Switchcraft #260 or #267 - 1/4 inch stereo phone plug
- 1 ea. 1/4 inch stereo phone jack
- 1 ea. 3/64 inch diameter brass rod
- 1 ea. 1/64 inch x 1/4 inch brass sheet
- 2 ea. adhesive rubber feet
- 1 ea. cable assembly (see text)

### **Tools**

- 1 ea. fine cut needle files
- 1 ea. 5/64 to 5/32 inch drill bits (see text)
- 1 ea. tapered reamer
- 1 ea. small soldering iron
- 1 ea. small bench vise (see text)
- 1 ea. third-hand device
- 1 ea. heavy-duty wire cutters
- 1 ea. needle-nose pliers (see text)
- 1 ea. hobby knife

## Construction

1. Using the heavy-duty wire cutters trim the plug's ground lug to an overall length of 15/16 inch. Take lug and completed sub-assembly measurements from where the plug's barrel connects to the threaded base. Cut the protective nylon shield from the ground lug with the hobby knife and discard.

2. Trim the tip lug and ring lug to an overall length of 3/4 inch. File all cut edges smooth. A threaded hole or soldering hole in the tip lug should be filed flat to aid fitting of the contact arm.

3. Trim two 1-3/16 inch contact arms from 3/64 inch brass rod. Square the ends and file cut edges smooth.

4. Trim one 1-1/2 inch paddle lever from 1/64 x 1/4 inch brass sheet. Square the ends and file the cut edges smooth.

5. Using the 5/64 inch drill start a tensioning hole centered 7/16 inch from the end of the paddle lever. Open the hole to 5/32 inch in the thin brass with progressively larger drills or a tapered reamer. Round off the corners slightly on the end that will hold the fingerpiece.

6. Now use the small bench vise to position the plug horizontally with the prepared terminals projecting from the jaws. The height of the plug should match the height of the third-hand. It will hold the contact arms and paddle lever in position for soldering.

7. Position the paddle lever in an alligator clip on the third-hand. Locate the part so the inner edge of the tensioning hole is immediately above the outer end of the ground lug. The operating end of the lever will then be 2-1/8 inches from the base. Adjust so the lever is perfectly horizontal, vertical and centered when contacting the ground lug. Solder the lever.

8. Following the instructions in paragraph 7, solder the contact arms to their respective lugs. The arm should project 1 inch past the end of the tip or ring terminal lug. After installation the operating ends will be located 1-11/16 inches from the plug's base.

9. Confirm that the contacts and paddle lever clear the shell and then remove it. Now install the rubber feet on either side of the paddle lever to create the fingerpiece. Press together tightly after insuring their placement will not interfere with the shell or contacts. Re-install the shell after the following adjustments are completed.

## Paddle Adjustments

Using the needle nose pliers bend the tip of the contact arms inwards 45 degrees. Adjust so each tip is the same distance away from the lever. The actual travel between the arm and contact is a builder preference. This bending process is a coarse adjustment. Here are three fine adjustments:

1. Adjust the contact sub-assemblies by bending them at the soldered lugs using the needle-nose pliers.

2. Alternate the dot-dash polarity to determine the best feel. Each

contact arm will be somewhat different because of the way the plug's tip and ring solder lugs are constructed.

3. Slide a one-quarter inch by 3/16 inch diameter heatshrink tube over the lever arm lug, contact arms and the tensioning hole. This addition can set contacts very close and will tighten the action slightly. Shrink the material incrementally with the heat from a soldering iron and test continually for best feel. Then file a small triangular notch in the top of the lever arm at the edge of the heatshrink to serve as a stop. It will prevent the tubing from sliding forward in use.

Lever resistance can be lightened while construction is taking place or done later after the builder has a chance to try the standard paddle. Here are three lever adjustments:

1. Enlarge the tensioning hole slightly with the tapered reamer or a larger drill. The lever will have to be unsoldered to accomplish this.

2. Lengthen the tensioning hole by filing towards the fingerpiece with a round file or by drilling another hole adjacent to it. Again, the lever will have to be unsoldered.

3. File a very shallow lightening notch in the lever above and/or below the tensioning hole. A round needle file is recommended for this work.

As designed, the St. Louis Paddle requires a fairly light touch on the fingerpiece. Builders desiring a heavier feel or less lateral flex in the mechanism can increase the diameter of the contact arms to 5/64 inch. The tensioning hole may be made smaller or even omitted.

### **Builder's Notes**

The Switchcraft #260 or #267 stereo plugs feature heavy-duty screw or solder terminals as opposed to semi-flexible stamped metal terminals. The rigidity provided by the thicker lugs is required for this project. The plugs are available from Mouser as P/N 502-260 or P/N 502-267 and average \$5.00 in single units. There is no Radio Shack equivalent. However, this part and similar plugs are common finds at hamfests at significant savings.

When substituting plugs the lever and contact arm dimensions may have to be adjusted. Those plugs should also feature insulation between the electrically isolated base sections designed to withstand prolonged soldering temperatures, i.e. not plastic.

The recommended soldering technique rotates a lug to the six o'clock position. Align the part to be added with the third-hand device and then apply heat to the bottom of the lug. Now apply solder to the joint between the lug and the part. Use only enough solder to make a serviceable joint. Excess solder tends to bend thin metal parts out of line as it cools and shrinks.

Inexpensive solid brass rod and sheet brass in 12 inch lengths is available in counter displays in most hobby shops. This is sufficient material for many paddles at an average cost of .50 per length.

A third-hand device fitted with alligator clips in multiple universal joints is a must for locating the components for soldering. Position the clip horizontally for the paddle lever. Position the clip vertically for the contact arms. The plug itself can be held in the pages of a thick book if a small bench vise is not available.

Small needle-nose pliers work well but small straight-nose internal pliers (with smooth, cone-shaped jaws) are preferable for turning the ends of the contact arms inwards. The lever and contact adjustments are truly a trial-and-error process but quite reliable in use.

### **Cable Assembly Options**

A St. Louis Paddle plugged into a custom cable assembly allows the operator to send code some distance away from the rig or external keyer. A nearby flat surface for positioning a traditional paddle with weighted-base is not required. 24 or 30 inch cables are manageable lengths but builder preference applies. Here are two examples:

1. Paddle-on-a-Stick: Plug the paddle into a 1/4 inch in-line stereo jack which in turn serves as a handle. The Radio Shack 274-141C is readily available, low-profile and very lightweight. This system is appropriate for either two-handed or one-handed keying and definitely "trail friendly". After construction a tie-wrap strain relief should be added inside the plug.

2. Paddle-in-a-Bottle: This configuration uses a plastic pill bottle (1-5/16 inch diameter -16 dram typical) for a larger handle. It is fitted with a mating jack and intended for two-handed keying. For desk-top applications a matching lid should be fitted on the opposite end of the bottle. This addition keeps the pill bottle/paddle holder level when held down on a flat surface. Add a tie-wrap strain-relief to the cable.

Terminate the cable assemblies with 1/8 inch or 1/4 inch stereo plugs to mate with common keying jacks in commercial and kit equipment. 90 degree angle plugs are worth considering for rear panel insertion. Adapter plugs allow quick switching between sizes.

A high-flex shielded wire bundle is recommended for the cable assemblies. Re-cycled computer mouse cables are also suitable. Three conductors of computer ribbon cable are an inexpensive alternative for low-power equipment. When building multiple cable assemblies insure paddle polarity is identical for each unit.

### **Design Notes**

The St. Louis Paddle was designed primarily for portable or mobile use. The project offers operating conveniences in these locations while minimizing the damage potential for more fragile keying devices.

The size and placement of the tensioning hole in the lever arm provides efficient keying action while preserving structural integrity. The tactile expectations of the operator are met with slightly extended lever travel. It is a fact-of-life with such a simple mechanism.

The contact arms provide a slight "click" when keyed and thus some audible feedback to the user in quiet settings. Having the contacts and lever meet at the operating end helps control contact bounce and lever over-travel at higher keying speeds.

The adhesive used for most rubber cabinet feet increases in strength several times when two of the parts come in contact. The characteristic is used to good advantage for this project as no permanent adhesive or mechanical fasteners are required for the small fingerpieces.

Removing installed fingerpieces requires care but is not difficult. The correct procedure is to grasp them between thumb and forefinger and gently roll both off the end of the lever at the same time. The adhesive will survive many removals and replacements. The pads should not be allowed to come in full contact with each other after removal. A thumb-nail or knife blade forced between parts may then be required for separation.

In addition to a front-panel location, the paddle can be operated by inserting it into a keying jack installed on the rear panel of a rig. Instead of turning the rig around rest the hand on the top front of the cabinet and reach back to grasp the fingerpiece. This procedure is an option when encountering a faulty cable assembly in the field or discovering it was left behind.

In the tradition of learning to use a bug or paddle, one-handed keying (with either hand) requires practice to develop the skill. Once mastered it is a welcome operating convenience for contesting or mobile. Pressing the base of a hand-held in-line plug assembly on a desk-top or thigh provides stability and aids the learning process.

## **Customizing**

The position of the dot/dash sides can be identified in several ways for day or night operating. One method includes sandwiching rubber feet of different shapes, sizes or colors to create a distinctive fingerpiece. Colored or reflective tape, a notch or raised indicating surface added to the plug's shell are also effective.

Choosing half-round rubber feet provides a wider range of actuating angles for the fingerpiece. This is may be helpful to some users and particularly during one-handed operation. A common 7/16 inch diameter pad is a good starting size.

Solid steel or brass bar stock can be used to construct a desk-top base for a paddle. Select a size, weight and height compatible with personal keying styles. Drill or mill the stock to accept a mating jack. Finish with a non-skid base and the connecting cable.

## **Performance Issues**

The completed paddle is just about "bulletproof" unless the protruding brass lever is bent from a sharp blow. Even then damage may be field repairable with hand tools. All soldered joints and the contact arms are

protected inside the plug's plastic shell. Given the modest expense, adding a spare unit to the field kit is a sensible precaution.

The standard single-lever design sends code comfortably well into the 30 WPM range. The difference in feel between hand-held keying and keying from fixed equipment is noticeable. With this in mind builders may wish to tailor a paddle for a specific application.

An ergonomically friendly version of the St. Louis Paddle dedicated to one-hand operation is being discussed. A leg-mounted paddle accessory is in the design stage. An iambic prototype with adjustable contacts is under test.

## Conclusion

A St. Louis Paddle may be used at the operating desk, portable or mobile. Equipped with a cable assembly it offers alternatives to traditional desk-top code-sending systems. This is an inexpensive and easily homebrewed accessory that performs well.

@ 2000 by Dave Gauding, NFOR and Andy Becker, W0NVN - All Rights Reserved

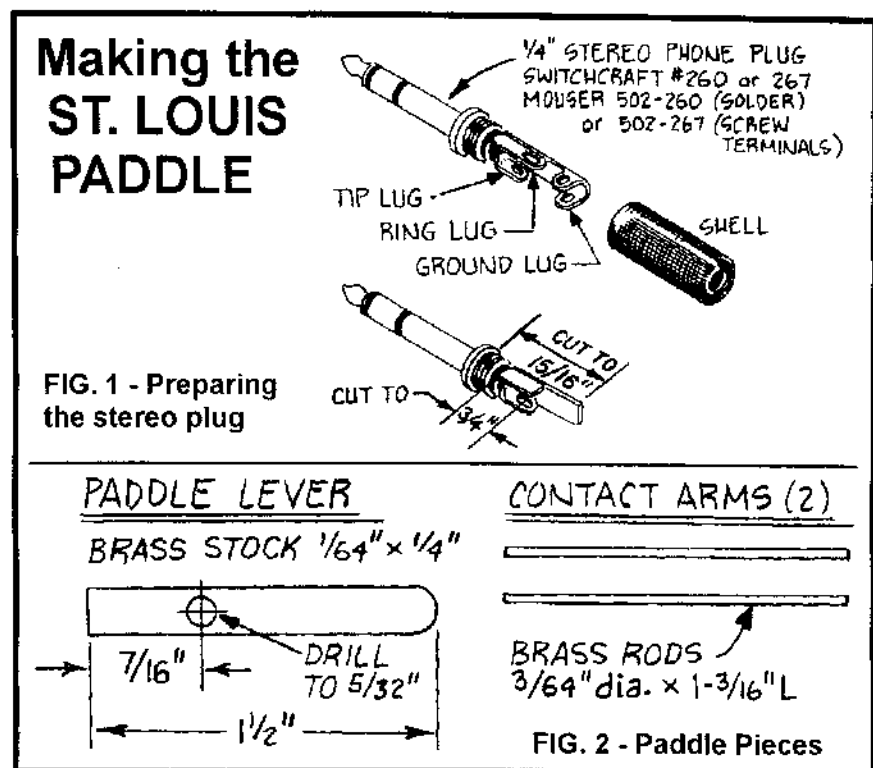



POSITION PADDLE LEVER ON  
GROUND LUG WITH PLIERS,  
HEMOSTATS OR 3RD HAND  
FOR SOLDERING.

FIG. 3 - Mounting  
the Paddle Lever

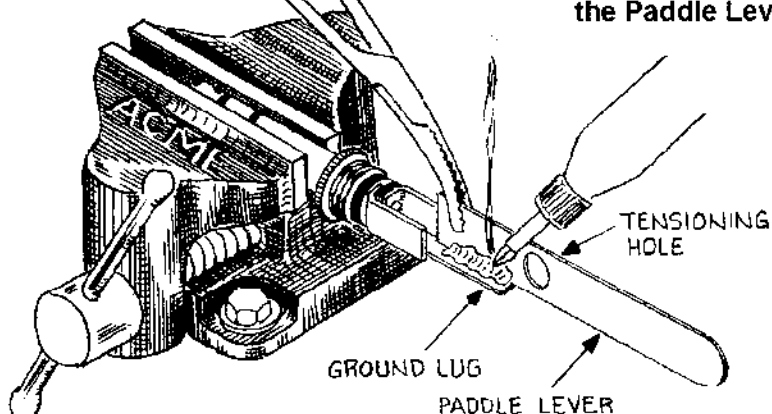
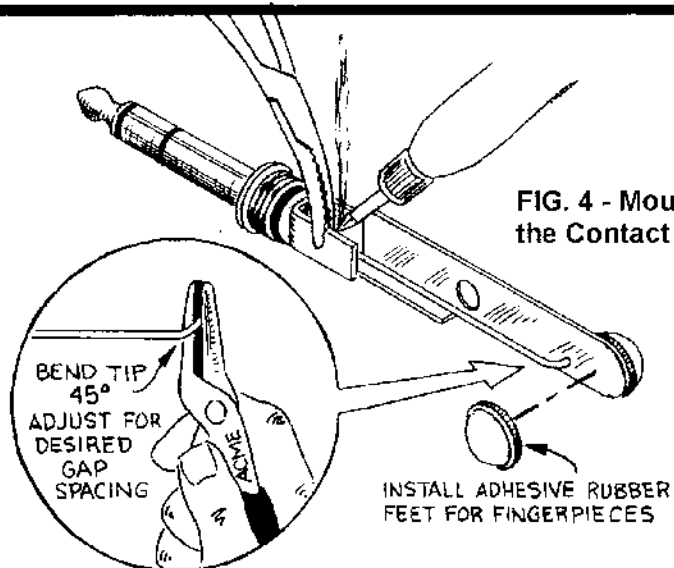

FIG. 4 - Mounting  
the Contact Arms



TOP VIEW

GAP

## PADDLE-ON-A-STICK

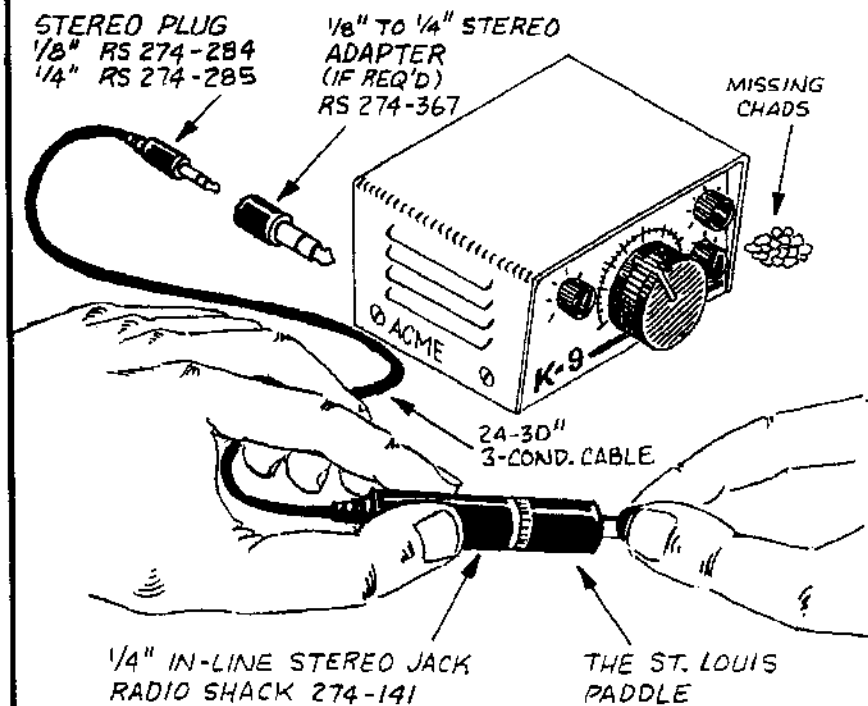

FIG. 5 - "Paddle-on-a-Stick" Construction and Usage

## PADDLE-IN-A-BOTTLE

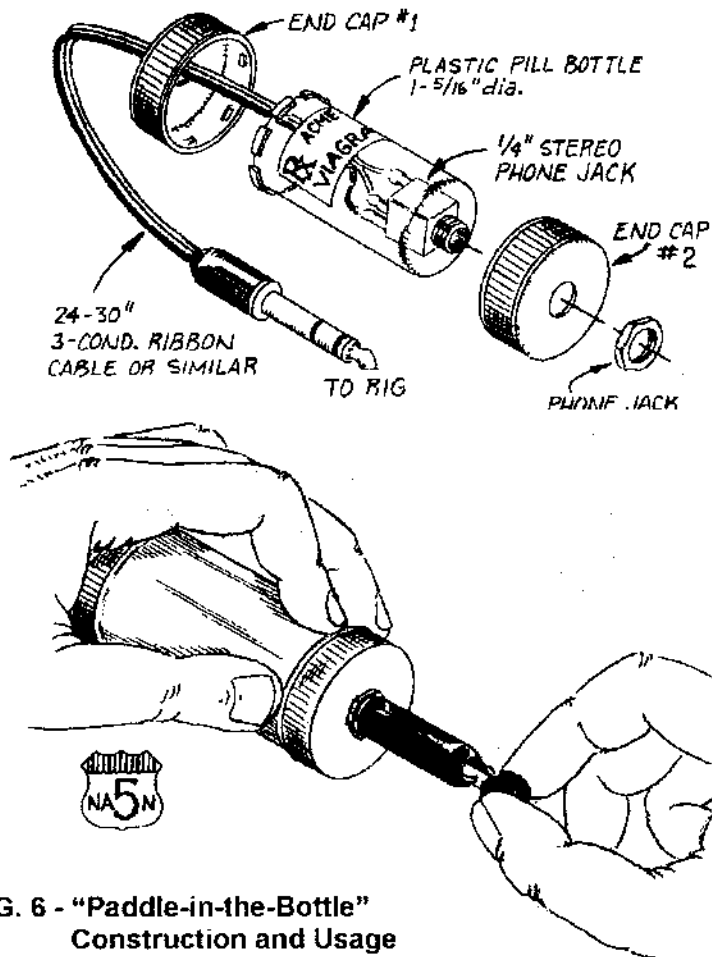

FIG. 6 - "Paddle-in-the-Bottle"  
Construction and Usage

# Test equipment



That doesn't cost a mint!

By Graham Firth G3MFJ/W3MFJ

## Part 1 - An RF probe for your meter

This is the first of a series of articles on simple test equipment. Test equipment does not have to be complicated to be useful. I cannot offer a circuit for a one-transistor spectrum analyzer, but you can do test to check the functions or any home-made equipment using such simple test equipment as this. This RF probe was one of the pieces of "Test Equipment that doesn't cost a mint" that Tony, G4WIF & I described at Pacificon late in October 2000.



It is a very simple circuit and is very effective in use. However, this does not stop people selling them at vastly inflated prices. I saw one at a local hamfest being sold for \$70+ and I am sure that it will have an almost identical circuit to this one.

Two versions are shown here. First, if you own a normal, non-autoranging digital meter, this will have an input impedance of 10Mohm and the first circuit below will suit this. The second circuit is slightly different and is designed to suit an analogue meter. These are usually 20,000 ohms/volt and the circuit modifications give a higher output, which will give a better indication on these meters.

The circuit for a digital meter.

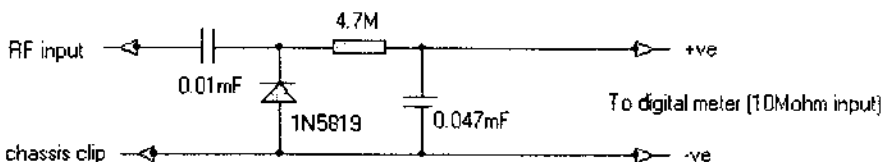

The two capacitors can be any type available, although if you intend to use the probe on voltages higher than 24 volts, the input 0.01 capacitor should be able to withstand this. The diode specified is a Schottky diode. This was chosen as it operates well at HF, and it has a low voltage drop, thus making it more sensitive. Any equivalent diode will suffice. If a Schottky diode cannot be obtained, then I suggest a germanium, rather than a standard silicon diode. The value of the resistor is calculated so that the meter gives an approximate RMS reading.

Now, here is the circuit of the probe for an analogue meter.

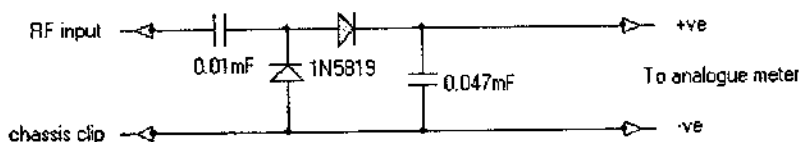

The same comments as above, apply for the capacitors. This time, to increase the voltage available, I have used two diodes to give a voltage doubler. Again I recommend Schottky types, but the comments above also apply to them. The output is uncalibrated because of the lower impedance of the test meter, the impedance of the source will affect the reading.

The case I used came full of 0.5mm leads for a refillable pencil. Whenever I get anything like this, I put it to one side just in case I can use it for some future project.

The RF probe can be used to detect an RF signal anywhere in a circuit, for example, to test whether a crystal is oscillating, or, to check whether a frequency multiplier stage is giving an output. The absolute value that you read usually does not matter, however, some designers will give a value, or a range of values to expect and this may be used as a guide.

In future issues of this magazine, Tony and I will describe other simple pieces of test equipment.

## Test equipment



That doesn't cost a mint!

By Tony Fishpool G4WIF/K4WIF

One of the most fun chips that has been available for years is the NE555 timer, they cost pennies, and you can use them for all kinds of things. In the September 1996 issue of QRPP, I used a double 555 (the NE556) as the heart of my Spectrum Wavemeter <sup>(1)</sup>.

In this article, I have used a single 555 to provide a simple and inex-

pensive audio signal source.

If you have a suspect audio amplifier, you can fault find on it with a multi-meter (if you have an idea of what voltages should be present, and where) or either by replacing it with another (test) amplifier, or by injecting a tone and work your way back from the speaker where, hopefully, the signal will get louder, if it doesn't, you are well on the way to finding where the problem lies. This piece of test equipment could be made even simpler by having a fixed frequency, but it doesn't make it too complex to get it to cover approximately 650Hz to 7.2Hz. The output is square wave, but that doesn't matter for test purposes. In order to crudely control the level of signal to be injected, use whatever potentiometer you have in your junk box, and if they are really small, the whole thing including battery will fit in an Altoids tin.

**Notes:** 1) In the September 1996 QRPP there was a mistake in the diagram of the Spectrum Wavemeter. In the circuit, the line between R6/R7, and C5/C6, are not joined and there wasn't an R11, even though it was listed!

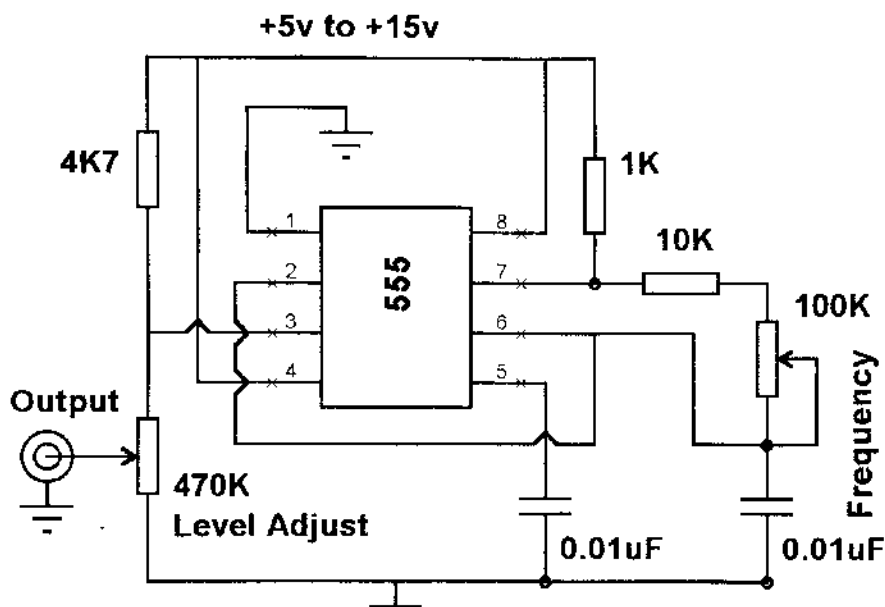

## K20 CW Keyboard/Keyer

By Steve Elliott  
K1EL @ aol.com  
8002445800

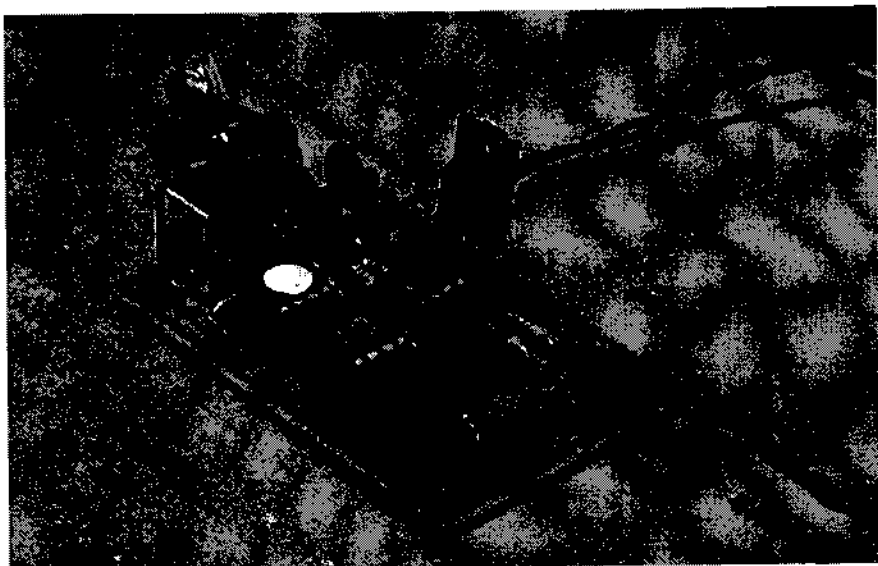

Here's a fun little project that you can build in a couple of hours and have fun with right away. It's a combination CW keyer and keyboard that can key your QRP rig (or most any rig for that matter). It has many features to play with and is easy to build and use. A kit is available that includes all the board mounted components and a single sided PC board. This kit is suitable for a beginner or a club project since if it's built right it'll work, no alignment is necessary.

The intent of this article is to cover the development and architecture of the design. Detailed information about the features of the K20 can be found in the K20 User's Guide on my website: [www.k1el.com](http://www.k1el.com) In writing this article I hope to pass along some of the things I learned in the design process which might spark an idea or two in other hams.

### **Design Requirements or "What makes a good CW keyboard design?"**

Here's where it starts, an organized list of what's essential:

A standard IBM keyboard interface with an on board PS/2 style connector.  
Open collector Key and PTT outputs for connection to a transmitter or transceiver.

Sidetone that has both high and low level audio outputs.

Iambic paddle and straight key input.

Non volatile storage memory for messages, settings, and typeahead buffer.

LEDs to give the user feedback on operating mode and status.

All commands to be issued via the keyboard, no additional switches  
On board voltage regulator able power keyer circuitry and a keyboard  
RF filtering to prevent RFI and malfunction due to externally induced RF  
Low power consumption and Small physical size  
Easy to find components  
Microcontroller with plenty of program space and I/O capability

### Easy Choices First

The Microchip PIC was the microcontroller of choice due to its low cost, powerful feature set, and the availability of free development tools from the manufacturer. A two-kilobyte serial I<sup>2</sup>C EEPROM was selected for memory because it's nonvolatile and has a simple 2-wire interface. Nonvolatile means the memory retains its contents even when power is removed. This makes it ideal for storing messages and operational settings of the keyer. Instead of adding LEDs to the PC board, the Scroll Lock and Caps Lock lights on the keyboard will be utilized. For testing and convenience an on board peizo speaker for sidetone was a "must have".

### It all comes down to pin count and program space

PICs in eight pin packages are a personal favorite since they don't take up much space and PC board layout is easier. On the other hand, a small package provides fewer I/O pins. Of the eight pins on a PIC 12C672, two are reserved for power leaving only six for I/O and one of those is input only. A nice feature of the '672 is its built in RC timebase oscillator eliminating the need for an external crystal or resonator. The RC oscillator suffers in absolute accuracy, but it's very stable and fine for a CW keyboard design.

This is a list of I/O pins required to implement the feature list:

PC Keyboard I/F	2	bi-directional
Transmitter Key	1	output
PTT	1	output
Audio Sidetone	1	output
Iambic Paddle	2	inputs
EEPROM I/F	2	bi-directional
Power & Ground	2	pins
<b>Grand Total of 12</b>		<b>pins</b>

That seemed to eliminate the 8-pin package. The next consideration was programming space. The PIC family incorporates program memory inside the part. Based on keyers I had designed in the past, the Morse generator, keyboard, EEPROM, and command modules would require at least three Kwords of program space. A PIC that would provide more than two kilowords of code space *and* provide enough I/O pins would be expensive and cost more than two PIC12C672s. Thinking along these lines, I



realized that two '672s could provide all the I/O needed and a total code space of four Kwords. I'd have the advantages of two small packages, low cost, plus internal RC oscillators. The trade off was that some of the I/O pins would have to be dedicated to support communication between the two PICs.

### Divide and Conquer

How could the design be broken in two parts? A natural split emerged between Morse generation and keyboard interface. I could partition the design into a "Console" that would read the keyboard and manage the EEPROM, and a "Keyer" that would generate Morse and sidetone, monitor the iambic paddle and keep track of event timing. The Console would "talk" to the Keyer over a standard 1200-baud asynchronous serial interface, which would cost four I/O pins, two pins on each side for data and handshaking. I was almost there until I counted up the pins again, **RATS!** I was short one I/O pin. The 12C672 PICs have a built in analog to digital converter (unbelievable but true) and these are great for replacing multiple logic level inputs with a single analog input. With the resistor divider network shown in Fig. 1, two paddle inputs can be fed into a single A to D input pin. There are four paddle states: both paddles off, dit paddle pressed, dah paddle pressed, and both paddles pressed. Each state feeds a different voltage to the Keyer PIC. By converting this voltage to a digital value the PIC can determine the paddle state.

There is an interesting benefit derived from splitting the design. Since standard asynchronous 8 bit communication was chosen as the interface protocol between the Console and the Keyer, any 1200 baud asynchronous serial host can control the Keyer.

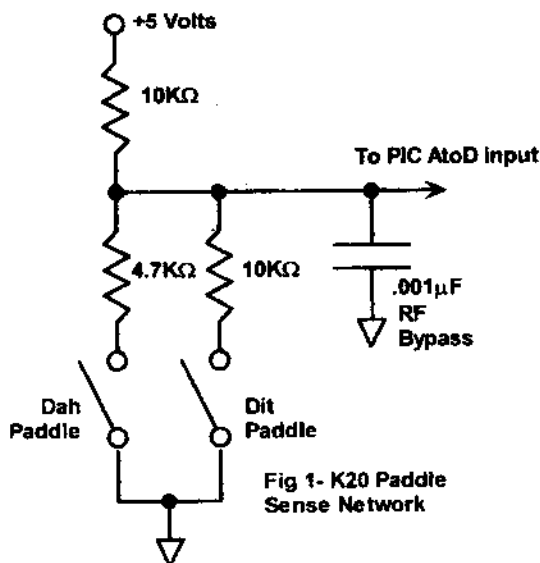

Fig. 1

## Two Chips Two Worlds

Figure 2 is a block diagram of the split architecture. Now that the design had been split, the software program had to be partitioned into two independent pieces. The next sections discuss the result of the design evolution.

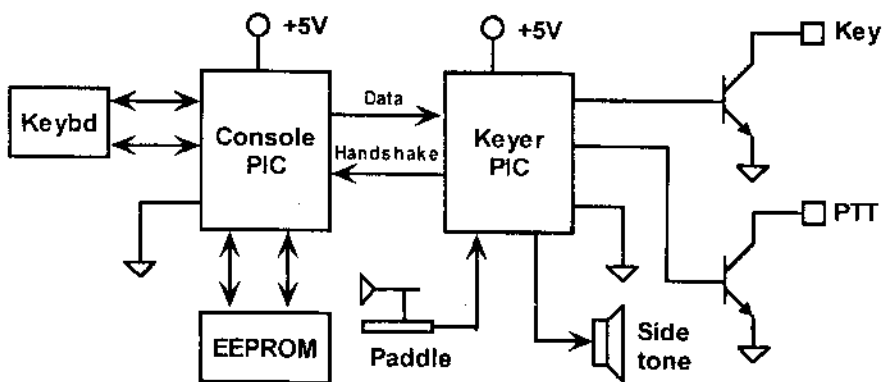

Fig. 2 Simplified K20 Block Diagram

### The Console Sits and Waits

The Console PIC operates in an event driven mode. This means that most of the time it sits in an idle loop waiting for something to happen. Events need to be serviced quickly, but from the PIC's point of view, there is lots of time between events. The two events that trigger the Console into action are keyboard key presses and Keyer PIC being ready to accept data. Since we can generally type much faster than the Morse code we're generating, the overflow needs to be stored temporarily until the Keyer is ready to take it. This is the primary purpose of the EEPROM memory. The Console puts the overflow into the "typeahead buffer" memory and takes it back out when the Keyer is ready to accept it.

When a key is pressed the keyboard sends data in serial format to the Console PIC which reads it in, reassembles it, and then parses (examines) it. The data can take one of two paths; be sent as a Morse letter or be treated it as a command. As we just discussed, Morse letters go into the typeahead buffer while commands are treated differently. A command is something that changes the operation of the system in some way, a speed change for example. Commands are of two types, immediate and buffered. Immediate commands are sent to the Keyer PIC right away, bypassing the typeahead buffer. If you make a speed change you usually want it to take effect immediately. If a speed change command were put into the typeahead buffer, all the Morse letters ahead of it would have to be sent first before the speed change could happen. There are situations where you don't want a command to take effect immediately. Let's say we want to send a two part message. The first part at 12 WPM and the second part

at 20 WPM. By inserting speed change commands in the typeahead buffer with the Morse, the speed changes will be delayed and happen at the desired time. Buffered commands are used most frequently in messages, while immediate commands are used on the fly or during keyer setup.

The Console interfaces to the user and must be easy to use. Commands are assigned to function and control keys in a logical manner and all commands have the same basic "look and feel". The availability of a large program space allow lots of features and a sophisticated message language. Configuration commands allow the keyer to be tailored to the user's taste. A setup can be permanently stored in EEPROM so that the operating state can be restored after power off.

### The Keyer is a Clock Watcher

The Keyer PIC isn't driven by events; it's driven by a real time clock. The Keyer's tasks are time critical and must be done in sync with a reference clock which, in the K20, is 8000 Hz. Every 125 microseconds (1/8000 Hz) the PIC is interrupted. Each time it stops whatever it's doing, and checks a task list. Here's what's on this list:

- Receive serial data bits sent from the Console
- Generate Morse dits and dahs at the correct speed, weighting, and spacing
- Generate a smooth sidetone at a specified frequency
- Control PTT output keeping track of lead-in and tail delays
- Monitor the iambic paddle inputs
- Issue flow control back to the Console

The software routine that checks the status of all these tasks must be very efficient, if it takes longer than 125 microseconds we overrun and miss the next interrupt. Figure three illustrates how interrupt and background processing interleave. Note that the interrupt processing time varies by the amount of tasks that need service.

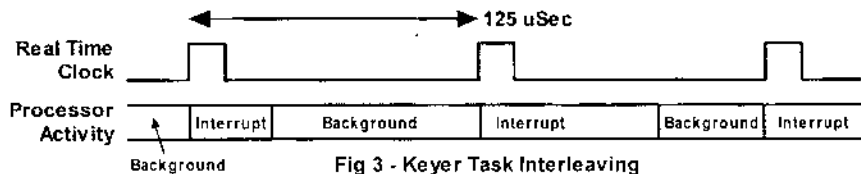

Some tasks are simple enough to service in the interrupt routine while others take many milliseconds to complete and have to be run in the background. Background processing is what the Keyer does between interrupts. The best way to understand how this works is by some examples:

## **Sidetone generation**

It is very easy to generate a squarewave output that can be used as sidetone. For example, a 1000 Hz tone can be generated by toggling a PIC output off and on every 500 microseconds. This works out to be a toggle every four interrupts ( $4 * 125 \text{ mSec}$ ). We can generate different tone frequencies by adjusting the count; if we toggle every five interrupts we get a tone of 800 Hz, if we toggle every three we get 1333 Hz. Since counting and toggling an output bit are simple, this task is done in the interrupt routine.

## **Send a Dit**

Dit and dah generation depend on accurate timing which is easy in an interrupt driven scheme. To start a dit we assert the key output, enable sidetone, and load a counter with a value equal to the length of a dit divided by 125 mSec. For 5 WPM this is  $240 \text{ mSec}/125\text{mSec}=1920$ . On every subsequent interrupt, we decrement the counter until it reaches zero. When it's zero the dit's done so we de-assert the key output and turn sidetone off. Then we start an inter-element delay which is also equal to a dit time. The beauty of this scheme is that dits, dahs, and spacing can all be accurately timed independently of background tasks.

## **What's all this talk about background?**

A speed change command sequence is a good example of background processing. The Console sends data to the Keyer serially, one bit at a time. The Keyer must accurately sample the serial input pin at the correct time in order to pick out the bits correctly. Obviously, something this critical must be done in the interrupt routine. The serial data rate is 1200 baud, which is a bit every 833 microseconds, and data is sent in groups of eight bits (one byte). It takes about 53 interrupts to accumulate a full byte after which the Keyer has to figure out what was sent. Here is where we run out of time in the interrupt routine. About all we have time to do is set a flag that says a full byte has been received and let the background figure out the rest. In between interrupts, the background process sees the byte ready flag and checks if a command or data was received. Since it's a speed change command, two more bytes must be received to obtain the new speed. A 2 and a 0 for 20 WPM. Next, a little bit of math is done to calculate new dit/dah times. The whole process takes hundreds of milliseconds and is constantly interrupted every 125 mSec. Background tasks are not critical so they can take as long as they need to. Even though a speed change could take 400 milliseconds it still seems instantaneous to the user!

If the serial data sent by the Console had been a Morse letter, background processing would be very different. First, the incoming letter would be converted into a binary pattern representing the dits and dahs in the letter. Then one by one the individual elements of the letter are queued

and sent at the proper time by the interrupt routine. The keyer will not start the next letter until the current one is complete.

### **Nasty Realities**

Two issues in the K20 design deserve some additional discussion. First, how reliable is the analog paddle interface? Second, what is the life expectancy of the EEPROM?

### **Internal RC Oscillator Stability**

The 12C672's internal clock generator is based on an internal on-chip resistor-capacitor oscillator that is not the most ideal oscillator to deal with.

First of all, there is an inherent inaccuracy due to process variation during manufacturing. The Microchip 12C672 specification states that at a 5-volt supply and a temperature of 25 degrees C, the nominal RC oscillator frequency is 4.0 MHz with a minimum of 3.65 and a maximum of 4.28 MHz. This is a range of -9.5% to +7% and it directly affects the absolute accuracy of the K20's WPM settings, time delay calculations, and serial communications clock rate. Microchip's process is quite good and the majority of chips trim out very close to nominal. However, good design practice dictates that worst case must be taken into account. The most serious functional issue is intercommunication between the Console and Keyer. If one chip's oscillator trimmed out on the high side while the other on the low side the communications rates could be off enough to prevent the Console from talking to the Keyer. To counteract this possibility, Keyer and Console chips are programmed in pairs from the same manufacturing lot. Process variances tend to be uniform among parts manufactured at the same time.

The other oscillator error is instability due to changes in temperature and voltage supply. Voltage supply sensitivity is reduced since the K20 has an on board 5-volt regulator. Temperature is a consideration however. Going back to the PIC12C672 specification we find that the frequency can vary from +.3 % to -.6% over a temperature range of 0 to 50 degrees C. This is barely noticeable from a user's standpoint and an error of this magnitude can be tolerated in the serial communication design so it is not of concern.

### **Paddle Reliability**

When a paddle is pressed, the voltage applied to the PIC's AtoD input does not change instantaneously. A .001 mF RF bypass cap insures that we ramp between voltages. By examining the paddle resistor network diagram we can see that the "no press" voltage is 5.0 volts and can calculate that a "dit press" value is 2.5 volts and a "dah press" value is 1.6 volts. If we are unlucky enough to press the dah paddle so that it is sampled "on the way" from 5 to 1.6 we could read 2.5 volts and think a dit was pressed. In addition, switch contact bounce adds to sampling error. The solution to

these problems is to perform multiple samples to insure that we have read a settled value. The more samples the better but we can't compromise paddle response time. Three matching samples over a period of 500 microseconds prove to be very reliable. Follow-up measurements with an oscilloscope found the worst-case delay of this scheme to be about 1.4 milliseconds. If we are sending at 20 WPM this is a delay of approximately 2.5% of a dit time which is imperceptible.

To decrease sensitivity to resistor tolerance the PIC looks within a range of values to distinguish between paddle states. The high and low limits take into account worst-case resistor tolerances so that inexpensive 5% or 10% resistors can be used. Dirty paddle contacts can cause problems. If a paddle press voltage is not stable due to paddle contact resistance the PIC may have difficulty obtaining matching samples and a paddle press could either be delayed or ignored. The high resistance values used in the divider network reduce contact resistance sensitivity considerably, but a contact instability greater than 80 ohms can cause problems.

### **EEPROM Life**

The second "nasty reality" is the use of EEPROM for the typeahead buffer. For all its advantages, EEPROM has one big disadvantage; a nominal life of one million erase/write cycles (for a Microchip 24LC16B). This means if you pick a location in the EEPROM and write to it one million times the manufacturer no longer guarantees that the location can be written again reliably. So do we have a ticking time bomb? Is the K20 going to just stop working someday? Well, the correct answer is yes... if you use it long enough. Some simple math shows: one million accesses multiplied by 200 locations in the typeahead buffer give us 200 million guaranteed keystroke writes. Now, if we sat down and started typing at an even rate of 35 WPM we could send **non-stop** for  $(200,000,000 \text{ letters} / (35 \text{ words/min} * 5 \text{ letters/word})) = 1,142,900 \text{ minutes} = 793 \text{ days}$  or slightly over two years. If you back off a bit and only send for four hours a day, that time increases to thirteen years !

### **Wrapup**

That's a quick look at some design issues of the K20. Kits are available at a low cost to entice folks to build and learn. A kit including PC board and board mounted sells for \$25. You supply the following components: a case, power supply, and connectors. The PC board is a breeze to assemble, all through-hole, with a forgiving layout that is easy to solder. Further information is available at [www.k1el.com](http://www.k1el.com).

## The Rochdale Mini QRP Convention 2000

by Dick Pascoe G0BPS [Dick@trickie.com](mailto:Dick@trickie.com)

The end of October each year sees the premier QRP event in Europe, another one of those special things where you are not a European into QRP unless you have been at least one.

The Annual QRP Mini QRP Convention is held at the Church of St Aidans in Sudden of Rochdale in the north East of England. It is the also the home parish of one of the most well known QRP'ers in the world. The Rev George Dobbs G3RJV has run the convention with the aid of a few friends (and of course his wife JoAnna G0OWH) for the past 12 occasions.

This is not a British Hamfest in any sense of the word, it is a genuine convention held in true QRP style in a small Church hall. If more than 350 turn up we are in trouble!

The hall is set out in the same way each year with a ring of QRP related traders around a central area for visitors to sit and chat. The doors open to visitors at 10am (ish) and depending on the cold British weather at this time of year there may be a small crowd of three or four waiting to get in. The weather this year has been awful with heavy rain and floods all over the UK. We even had snow in Rochdale the Monday after the convention!

The style and flavour of the convention hasn't changed over the years. The faces change slightly but not much. I seem to remember Roy Lewallen W7EL saying that in the 70's he was the average age of a 'Ham' here we are; thirty years on and we are still the same. The same age as the average 'Ham' where will we be in thirty years time?

Visitors in the past have included several from the US. Luke Dodds one time treasurer of the ARCI and their (then) President Paula Franke has both been over. Even Derry Spittle from Canada has been a few times. A few more have also made it but we still wait to welcome the top guys of NorCal. Rumours have it that Doug is sneaking over the puddle next year! We truly hope so. Other visitors come from all over Europe and include some top names in their Country. Petr OK1CZ, Peter PE1MHO, Rudi DL4UH, Rene ON4KAR.

The day passes quickly with the speakers actually using the Church for their forums, complete with Overhead projector and Mic. Speakers this year included Tuc Choy from VK land (missed his call) and the usual Rob Mannion from Practical Wireless Magazine. Visitors to Dayton will remember Rob with pleasure. Rob has a regular spot each year covering the happenings through the UK.

The other regular spot is that of David GM4ZNX. David is one of those very rare beasts who have what is called 'Total Recall' what may seem a boon to some could be a difficulty to others. Ask David a question and he will answer it. ANY question! If you don't understand his reply first time he

will gently lower his standard until you do. I have listened to him describe the inner workings of a Spectrum Analyser to one and a few moments later describe a diode to another. Without making the listener feel awkward.

Without doubt the lunch is the highlight of the day, except this year there was a terrible failure on the part of George G3RJV to actually determine that the lunch was complete. We ALWAYS have 'meat pie, mushy peas and pickled red cabbage'. This has become a favourite of all attending. This year George failed to order the 'mushy peas' and we had a peapless lunch.

The wives of helpers, and ladies from the church muddle in to work the kitchen and for the past 12 years it has helped keep my wife busy and out of my hair so I can enjoy myself!

This is a very friendly show, as almost everyone knows everyone else. If they don't when they start, they do when it finishes.

The helpers are invited back to the vicarage in the evening after we have all cleared the hall and got it ready for the Sunday morning hordes. Johnny Appel and his wife Birgita usually add to the piles of Chinese food. Their salmon and herring dishes brought in from SM land are gorgeous. (I usually ignore the Chinese food until the fish has been well tested).

Friday is hall set up day and those who arrived early get stuck in and get the entire table and chairs set out. Sunday is wind down day with a visit to Church with George and JoAnna and a leisurely lunch to follow at a local hotel.

If you are tempted to visit the UK soon then beware, this event is VERY laid back. No hustle and bustle and no pressure to do anything except enjoy yourself. We open the doors at 10am and the last visitor usually is gone by 4pm. We are typically clear by 6pm and sat with a well-earned drink in our hands.

Local hotels are available from \$50 upwards with a few cheaper ones a little further afield. You could fly direct from the US into Manchester, which is a 30-minute cab drive from Rochdale. Of course you could make it part of your annual vacation.

The UK is very small compared to the US we are under 1000 miles from the northernmost part of Scotland to the southernmost part of England. We can drive a little faster than you too, with luck and a blind eye from the local bobby (police officer) you can cruise easily at 85mph on our motorways (freeways) though the legal limit is 70mph.

If you fancy jumping the puddle in the near future please let me know and I will offer any advice that I can. I don't know all of the UK but I am certain that I know a man that does.

Finally I would like to reiterate a comment from WB9TBU when she visited Dover Castle near where I live. She saw some graffiti on a wall in the castle covered by a plastic sheet to protect it.

I explained that prisoners of war had done it. Not those from WW2 or even WW1 but from the Napoleonic wars in the 1700's. When France and



England were at war. Her comment will stay with me always. "Gee, you have graffiti on walls older than we have buildings" Dover Castle was built in the 1400's.

Please do join us some time for Europe's very best Mini QRP Convention. We would really love to see you there. Email me for more information at [Dick@trickie.com](mailto:Dick@trickie.com)



George Dobbs, G3RJV accepts \$700 from Graham Firth, G3MFJ, on behalf of the NorCal QRP Club as a donation to the Parish Fund of St. Aidan's Church, where George is the Vicar. The money was raised by a raffle of QRP kits at Pacificon 2000, which was won by George Heron, N2APB. NorCal members were very generous in their donations, and St. Aidan's Church is very appreciative of the gift. The presentation took place at the annual Rochdale Qrp Convention held in St. Aidans.

## QRP To the Field: 2000

by Jan Medley, N0QT

NorCal Contest Manager

Here are the final results from QRP To the Field 2000 held on the last weekend in April this year. A total of 81 log entered and tons of great pictures. Keep up the great work gang!

### MARINE MOBILE STATIONS

Call	QSO	FINAL	Call	QSO	FINAL
NQ4RP	121	319700	WB3GCK	40	51775
W0CH	86	209975	NQ5RP	28	32000
W5KID	34	66150	NK3ST	17	18275
NS8O	32	51975	K7FD	15	6840

### OCEAN STATIONS

Call	QSO	FINAL	Call	QSO	FINAL
N0UR	150	443920	AL0HA	46	61600
N9AW	142	375840	W3CD	34	42680
AE9K	118	288080	WA6NAE	42	39040
K2QO	94	223380	N4JS	29	33200
W9XU	89	203320	N6WG	43	16380
K0ZK/1	65	120080	WA9WAC	21	11000
NK9G	66	98340	KI6DS	20	10080
W0UFO	58	93000			

### OTHER WATERS STATIONS

Call	QSO	FINAL	Call	QSO	FINAL
AA5B	153	400995	AC6NT	31	29700
W0CQC	140	269280	WT9S	28	29520
N4DD	126	247950	KF2EW	37	28800
WA7LNW	116	234900	AB8DF	30	26070
AK7Y	102	164820	KD3FG	27	22500
W5TB	92	160740	N5SAN	26	20520
N7KE	95	159285	NK7M	25	20250
K4JSI	61	145920	VE6QRP	24	16065
K7RE	80	112800	W4IM/8	28	15555
WD7Y	69	107070	AE5X	23	14280
K5HQV	61	100035	KF4AR	11	5550
AF5Z	61	93480	VE3SMA	20	5520
W7TAO	50	66030	AC6AN	12	5265
K5AAR	58	62250	KI0KY	10	4200
N7TX	49	59220	K6UIZ	10	840

K7TQ	50	56280	K2HPV	6	810
N7KT	37	40455	N3FZX	3	90
WA5BDU	42	33705			

### FIELD STATIONS

Call	QSO	FINAL	Call	QSO	FINAL
W4GGM	65	57400	KE9GM	33	11830
AD6GI	38	23920	KG9PQ	19	6720
W0YSE	31	20880	N1IRZ	14	3150
AF4PP	29	15480	WA9YDJ	12	1900
AB5XQ	25	14820	WA9PWP	3	270

### HOME STATIONS

Call	QSO	FINAL	Call	QSO	FINAL
K5KW	144	97150	N0IBT	25	5130
W1VT	92	59045	AA9NF	26	5025
N8XI	102	58650	AL7FS	14	1870
NQ7X	63	30970	VE5QRP	10	1215
N9MZP	46	20880	JR0BAQ	10	870
W3MWY	27	8470			

### CHECKLOGS

#### Call QSO Claimed

AE6N	26	15120
W7/JR1NKN	9	6480

81 Logs Submitted

### Soapbox:

Hello again QRPer's. It is very much fun to join QRP contests held in stateside from Japan! I hope that more DX stations (from your side) will join to these contests. I could not operate from outdoor because the time was from midnight to morning here! (0000-0900 local time). Kohei, JR0BAQ

I only wish I had known about the Water World thing earlier as my seafaring family, of which I am but one, would have provided space on any of a dozen vessels. Ha! George, W3MWY

I'd like to see the Water Theme run again if possible because we have a small manmade lake in the middle of Regina. Even though I have a low score, it was fun and therapy and that's why I enter. Many thanks to all who made this event possible! Bruce, VE5RC/VE5QRP

[Well said, Bruce. I like field contests because it gives us all a chance

to drop out of the fast lane for a few hours and a good reason to get together with friends — Jan.]

Very tough conditions today. I worked only 3 QSOs in the first 90 minutes starting 1800Z. It was fun in spite of it all. Thanks to everyone for being there. Jim, AL7FS

Very fun contest. Had hoped to operate from my boat on the Mississippi River. Had to settle for home operation this year. Pete, AA9NF

Had plans to try the Ocean (Lake Huron or Erie) on my brother-in-law's boat. But, took on baby sitting duties with a couple of grand kids. Managed to work a few on 40, 20, 15 but heard no one on 10. Rick, N8XI

[Nice job anyway Rick, all the way around! Hope your grand kids will take an interest in amateur radio since they have a great Elmer in their grandpa — Jan.]

My first QTTF. Great fun! Could not make it to the water, so set up in my back yard. Put up a temporary dipole at 20 ft. Powered rigs with a 12V car battery and sat under a shade tree — Beautiful day! Bill, AB5XQ

I sneaked away from manning an all-day display at the mall to work a few QSOs from the parking lot. The "QRP section" of 20 meters sounded pretty lively, and it seemed like a lot of folks were getting in on the fun. My worst QRM came from massive, megawatt car stereos driving through the parking lot, blasting sound waves through the padding on my headphones. Dave, N1IRZ

Thanks for organizing this event. It was great fun and a perfect day — clear, sunny, and temperatures in the low 70's. Total operating time was 2½ to 3 hours, so was also able to get lawn mowed, oil changed in the car, trip to bank and PO, visit to nursing home, etc. (the usual Saturday "Stuff") done also. Chuck, AF4PP

Weather & other interruptions prevented me from doing as much operating as I would liked to have done — But I got to test my new 35 ft. portable mast consisting of a 10 ft. metal conduit, an 8 ft. dowel & topped with the Black Widow fish pole. Thanks for the contest — it was great fun! Neil, W0YSE

[Neil sent in some great pictures of his antenna — would make a great article for QRPP Neil! — Jan.]

This was my first contest with my new DSW 20 QRP kit. Great way to break it in!!!! Cal, KG9PQ

My first solo effort in a QRP contest. What a refreshing difference from QRO 'tests! It's nice to receive TRUE sig reports, instead of meaningless 599's all day long ... and QRP ops are much more polite during contests. I'm hooked. Steve, N7TX

[Thanks for the pat on the back, Steve. QRPers are a breed of their own, and we're a fun-loving bunch to boot — Jan.]

Great weather. Had lots of fun. Will be back next year. Ed, AB8DF

Man I love these field events, way too much fun. Propagation was poor, but the camaraderie was, as always excellent. Thanks to NORCAL, and all the folks who worked so hard to make this possible for all of us. Brian, K7RE

With rain in the forecast, I wasn't planning to operate and had no site picked out. But wx was perfect and I couldn't resist getting on! After some time exploring, I picked a pleasant spot on the bank of a stream and spent an enjoyable hour and a half on the air. Steve, VE3SMA

Great fun, after we ran Murphy off. The new DK9SQ mast collapsed, shattering the new DK9SQ loop matching box, so had to use the High Sierra screwdriver antenna. Had to cobble up the power cord for the K2, the original being back in the shack. Beautiful site, with a great view overlooking the lake. Very windy, though. Propagation not too good, but fun anyway. Bob, NK7M

[Bob, a lot of us have those DK9SQ masts and we all seem to have the same problem with them...collapsing! Let's make an appeal to the "Think Tank" and maybe there is a solution. I have 3 of the darned things — Jan.]

Took a canoe trip on Snake River in WA to my QTTF site. Great time! Randy, K7TQ

Another great contest by NORCAL! Conditions were not great and the high winds broke my antenna support lines twice, but had lots of fun. Greg, AK7Y

Heavy winds created a big of a challenge with antenna installation. Otherwise, terrific fun!! Jack, WA7LNW

Great contest! Warm, windy, lots of bikinis... Roger, N7KT

This is my second time operating QRPTTF in the field, so much fun, looking forward to next year. Ed, WD7Y

Great theme! Too bad our MM plans fell through at the last minute. Can't wait for next year's theme. Bruce, N7CEE/W7TAO

### **And This Says It All...**

This was my very first QRP contest — had finished my DSW-40 a few days ago and wanted to try it out. Worked 1600-1715Z, 1830-1930Z, and 2100-2300Z, but should have concentrated my efforts on the last 3 hours — east coast stations were starting to roll in. Up until a few days ago, I had been inactive for 25 years. QRP has grabbed me, though, and I'm looking forward to next time. I had a lot of fun even though I didn't work many stations. Thanks for a most enjoyable activity! Propagation conditions didn't seem that great during much of the contest, however. Vance, WA9YDJ

[QRP is fun and challenging so welcome aboard, Vance. There are lots of contests out there that are QRP only or have QRP categories, but even if they don't you can still submit your log as QRP anyway! I just send mine in as SO/QRP at 4W. Sometimes they add a QRP category to contests because they are getting more and more QRP logs! — Jan.]

Had a great time in my first QRPTTF. Bands seemed a little weak, so I took a long break to mow my yard :) — I was set up on a hill at the back edge of my property, overlooking my pond. Lots of good ops out there. Jay, WT9S

QRPTTF 2000 was a great outing. I took along N4UW, Luther, for his first QRPTTF. Conditions were good and we had lots of fun. Thanks for another great contest and we look forward to the next. Dennis, N4DD

Jon Mitchell, KD3FG, writes:

Ken, N3FZX, and I went to Scott's Cove in southern Howard County, Maryland (part of the Patuxent River State Park). We set up right near the water line and had to deal with the QRM from the various water fowl.

We assembled the fishing pole vertical and threw up a folded dipole in the trees. This dipole is becoming my favorite trail antenna due to it being cheap, it is easy to put up and it works really well on the bands! I built it with three 50 foot rolls of cheap Radio Shack 300 ohm TV twinlead. I was not able to get a good match on the vertical (poor planning on my part — I usually set the coil before an outing), so we really only used the dipole.

Ken had just finished his TAC-1 40m rig and this was the first time I had my K2 on an outdoor contest. Both radios performed well.

Ken and I alternated operating times on an hourly basis. I got in almost three hours and was able to work 27 stations. This is better than last year's score of 25 after 4 hours, so I am happy with the results. Ken scraped up three contacts (one being W1AW) in the novice section of 40m.

From the Redmond Top Key Contest Club, N7KE:

Ops — NW7DX, KB7N, W7HQJ, W7QC, W7ZF, KK7UT, W7HLO, K7SZZ, W9HXM

Well, another wonderful time had by the N7KE clan. Our station was set up at Lake Cavanaugh WA, and had a beautiful view of the water and mountains. We got off to a bit of a slow start, but really pulled it together as time went on. By the end of the contest we had racked up 95 QSOs, which is the club's all-time best. Our total SPCs was 41, which is also our best. Most of our operation was on 20 meters, but there were a lot of Monster signals on 15 meters as well! Our antennas were a 20 meter double zepp, and a double-delta loop array, for 20 meters also. These were fed into our K2 and Red Hot 20 (everybody in the club absolutely loved these rigs). Both were excellent performers.

When I (Ben Schupack, NW7DX) was in front of the rig, I heard many familiar calls and some new calls too. It sounded like the activity this year was up quite a bit from last year. Hopefully, it will be even more active next year. It sounded like towards the end of the contest, everyone was begging for contacts.

It was fun hearing all of the portable stations. Many of them had huge signals into the Northwest. Never did hear Jim (AL7FS) up there in AK, but did manage to work a Japanese station which was very nice.

I hope everyone had as much fun as I did. It was a great way to spend a Saturday afternoon.

TE "Doc" Drake, W5TB, writes:

Worked 3 hours in AM — set up at a picnic table under oak trees in a lovely park. Had to QRT at noon to join my Labrador retriever for a fund raising walk for the Pet Rescue Society. When I returned at 3:30, I discovered my double zepp \*gone\*! I found someone had stolen the ropes and trashed the antenna - which I found pieces of in the grass. Rather than quit, I hastily twisted the pieces together to form a random wire and counterpoise and was back on the air by 4 pm to complete the contest with another 44 QSOs (92 QSOs in all!)

[QRPer's are sure an ingenious breed of people — Jan.]

From Nick Kennedy, WA5BDU:

This was my first QRPTTF because usually the date collides with the Little Rock hamfest. Not this year.

The Site: There's a valley between Tibet and China walled off by mountains and almost completely inaccessible to humans. It features beautiful, towering waterfalls. I didn't go there.

At the back boundary of my yard is a creek, poetically named "Engineer's Ditch" on city drainage drawings. Completely grown up with underbrush, it's almost as inaccessible as that place in Tibet. It flows year round and occasionally leaps its banks and threatens my house. If you're

wondering if it's a real creek, it even has fish in it....okay, minnows. Also, there are fierce mosquitoes in the area of my yard. They are Laotian or something, have striped socks, and will bite you right through your Levis.

**The Stuff:** I set up my card table in the creek bed with one leg in the water. Spent the usual hour or more doing my Charlie Brown With Kite routine and finally got my dipole up a good 40 feet or so. I used my Red Hot 20 and an MFJ tuner plus choke balun. A 4-AH gel cell from BG Micro. Arkiecon 2000 QRP Mini-logbook from Doug and an old fashioned paper dupe sheet.

**The Results:** Not too bad for single band operation. Think I made about 40 QSOs. Didn't even work CA, WA or OR. Worked only one VE. Worked lots of zeroes, lots of CO and NM. Only celebrities I worked were Dr. Megacycle and W5KID. Worked a few county hunters. What are you supposed to say to 'em?

The gurgling of the creek was nice. And the roar of lawn mowers and my neighbor's backhoe added a Field Day kind of ambiance. Plus, there were leaf blowers, weed eaters and young guys with their Thump-Thump-Thump car stereos cruising by occasionally.

Several operations sent in photos. These have been placed on the NorCal Web Site at <http://www.fix.net/norcal.html> Check the great photo essay work done by our photographers in the field, our contest manager, Jan Medley, NOQT, and NorCal Web Meister, Jerry Parker.



## **The Epiphyte 3, A 75 Meter SSB Transceiver**

**Designed by Derry Spittle, VE7QK**

**A NorCal QRP Club Kit**

**Copyright 2000 All Rights Reserved**

*[The Epiphyte 3 is a remarkably simple, easy to build SSB transceiver for 75 Meters. It uses simple parts, which used to be easy to find. Sadly, some parts for this transceiver are very difficult to find in quantity, although it is possible to find them in lots of 1 or 2. NorCal kitted 100 of these transceivers in September, and they sold out in 1 day, less than 24 hours. We have been planning this kit for 4 years, and have had some parts for that long. We will not do another run of the kit, but present the manual here for those who might want to attempt to build their own, with salvaged parts from Epiphyte 1's and Epiphyte 2's. The club does have 40 PC Boards that are for sale for \$12 each. To order, send a check or money order for \$12 to Jim Cates, 3241 Eastwood Rd., Sacramento, CA 95821. Please enclose a self addressed mailing label to help Jim out. As always, please make checks and money order to Jim Cates, NOT NorCal. We do not have any parts available for the boards. You are on your own on that one. We hope you enjoy the article, as it has been a long time in development. Doug, KI6DS]*

### **INTRODUCTION**

***EPIPHYTE, a plant growing on another [f. EPI + Gk. phuton]O.E.D.***

The original Epiphyte was a simple transceiver designed to provide voice communication with the British Columbia Public Service Net on 3729KHz from wilderness areas of the province. It ran off AA batteries, was light enough to backpack, and had an output of one watt. Construction articles were published in both QRPP and SPRAT, circuit boards became available and fifty kits were produced. While only a few amateurs used it for the purpose for which it was originally intended it did succeed in introducing many of them to home construction of SSB equipment. It was fun to build and play with.

The Epiphyte-2 included a VFO and the power output was increased to five watts. Once again, construction articles were published and circuit boards became available. In 1996 the QRP Club of Northern California and the G QRP Club, as a joint project, donated fifty EP-2 kits to amateur operators in Third World Countries. It now features in the QRP section of the RSGB Radio Communication Handbook and feedback from amateurs around the world confirms that many have been and continue to be built and operated.

So how does the Epiphyte-3 differ from its predecessor?

The circuit board has been re-designed and professionally manufac-

tered with plated-through holes, solder resist and screened parts overlay.

The antenna connector, power connector, switch, RF gain control and lowpass filter are now installed on the circuit board reducing the number of external connections.

Audio-derived AGC has been added to the receiver.

Polystyrene capacitors have been replaced with smaller and more readily available NPO/COG ceramic capacitors.

The power amplifier has been heat sunk to the base of the enclosure. The improved heat dissipation permits it to operate at higher power without overheating.

The NorCal kit includes the circuit board and all components which are directly mounted on it the 10-turn tuning pot and terminal housings for the Molex headers. You will need to find very few parts on your own to get your EP-3 on the air.

Assembly is not intended to be a "winter construction project". Any amateur with some previous experience at building HF equipment and working with printed circuit boards will have little difficulty in assembling the EP-3 in a few evenings. Nor is it intended for the serious contester.

I hope you will have as much fun with it as I have. Feedback, suggestions and constructive criticism are always welcome,

Derry Spittle, VE7QK

North Vancouver, BC, Canada

e-mail: [jds@vcn.bc.ca](mailto:jds@vcn.bc.ca)

September, 2000

## ACKNOWLEDGMENTS

First and foremost to Doug Hendricks, K16DS, and NorCal for funding most of the development costs and making the EP-3 available as a kit; to Ed Burke, K17KW, Dave Meacham, W6EMD, and Graham Firth, G3MFJ for assembling and testing prototype boards. Their advice and suggestions led to a number of changes being made; to Wayne Burdick, N6KR, for allowing me to 'borrow' the AGC circuit from the SST transceiver; and Vern Wright, W6MMA, who assembled the final version without a manual, and has since worked me /M from Sacramento.

## THE CIRCUIT

Refer to the Block Diagram (Diag. C).

The EP-3 is based around a pair of NE602 double-balanced mixers U2 & 3 and a miniature 455KHz SSB filter F1. U6 (4066) switches the LF and HF oscillator between the mixers enabling them to be used for both transmitting and receiving.

The pre-amplifier U4 (LM741) is designed for an electret microphone and the audio amplifier U5 (LM386-4) will comfortably drive a small speaker.

The LF oscillator Q2 (MPF102) is tuned to 452.6KHz to produce an upper sideband signal at the output of the filter.

The HF oscillator Q4, or VFO, (MPF102) is tuned 452.6KHz higher than the output frequency to generate a lower sideband signal at the output frequency.

Conversely, when the oscillators are switched the receiver will demodulate a lower sideband signal in a similar.

The RF bandpass filter L3/L4 has a bandwidth of 200KHz and a steep cut-off to ensure adequate attenuation of the image frequency 900KHz higher. The filter terminates in a low resistive load at the input to U1.

The driver U1 (CA3020) is a high gain differential amplifier. A trifilar wound broadband transformer T2 matches the push-pull output to a resistive load at the gate of the Mosfet power amplifier Q1 (IRF510). Another broadband transformer T3 matches the power amplifier to a 50 ohm load.

L2/L3 is an elliptical lowpass filter. Both sections have been designed to afford maximum attenuation of the second harmonic of the output frequency.

Transmit/receive is accomplished with a miniature DPDT relay K1. One section of K1 switches B+ supplies. In the open position (receive) the voltage is removed from the microphone pre-amplifier U4 and the driver U1. Forward bias is removed from the power amplifier Q2. Closing the relay (transmit) removes B+ from the audio amplifier U5. At the same time this section provides the switching voltages to U6.

The other section of the relay connects the receiver input to the antenna via the lowpass filter when in the open position. It disconnects and grounds the receiver input when the relay is closed.

A simple audio-derived AGC is used to control the gain of the second mixer. For this to work effectively the gain of the audio amplifier must remain high. A manual AF gain control has been omitted. The RF attenuator at the input sets the audio level and only requires adjustment if an extremely strong signal overloads the first mixer. If headphones are used an attenuator in the lead will reduce the output to a comfortable level along with mixer noise.

An LED, inductively coupled to the antenna lead provides a simple modulation/power indicator

Output	8 watts PEP
Input voltage	12 - 14 voltage DC
Band	3.5 - 4.0 MHz
Coverage	Set to any 200KHz section
Sideband	Lower
Circuit board	2.9in x 6.0in
Total current drain	Receive: 50 - 100mA with speaker Transmit: 150 - 900mA with normal speech
Power supply	2.5 amp AC power supply or 5Ah gel-cell

## ASSEMBLY

A small clamp-on table vise great help. Cover the jaws with plastic

tape and always grip the circuit board by its edges.

I recommend that you make a temporary chassis from a 6" x 6" (minimum) piece aluminum for testing and alignment rather than use your final enclosure. Bend one side to form a 2" panel and mount the circuit board along the rear edge on the four threaded metal spacers provided. Use long screws and fasten it to the chassis with nuts on the underside. Screws and metal spacers may be left attached to the board throughout assembly.

All holes in the circuit board are plated-through. Never attempt to enlarge or drill them out. Adequate clearance has been allowed to permit the components to drop into place. If you have to unsolder and remove any component, avoid applying force. If a capacitor or resistor costing pennies does not come out easily, clip it in half and unsolder each piece separately.

The component layout is screened on the circuit board but bear in mind that the part number will often be obscured once the component has been installed. Refer then to the printout (Diag. E).

You can, of course "empty the bag, populate the board and smoke test". The following approach reduces the chance of mistakes and time-consuming trouble shooting later.

- Start with the BNC antenna connector J1. Make sure that it sits both flush with the face and square with the edge of the circuit board. Avoid applying too much heat as this will melt the connector housing.

- Install the power connector. Again, make sure that it is flush and square with the edge. One or more of the tabs might require filing down as their width appears to vary between manufacturers.

- Install the on/off switch SW1. Solder the mounting tabs first and make sure that it is vertical before soldering the leads.

- Install the five IC sockets. Check that each is correctly oriented, flush with the board and that all the pins protrude through the hole. If you start by soldering two diagonally opposite pins it will allow you to square up the socket before soldering the remainder.

- Splay the twelve leads of the driver amplifier U1 out about 30 degrees over a piece of 3/8" round material such as cap of a pen and then straighten the ends. Commence by inserting lead #12 (located beneath the tab) into the corresponding hole on the board. Working clockwise you will be able to insert four or five leads without any problem. Do not insert them any more than is necessary to keep them in the holes. Then use a pointed Xacto knife to guide each of the remainder into place. With luck you will reach pin #1 before pin #12 slips out! Centre U1 about 1/4 inch above the board. Double-check to be absolutely sure that it is correctly oriented before soldering in place.

Install the antenna current sensor T3. This is difficult to install once surrounding components are in place. The single turn primary winding passes once through the core and does not wrap around it. Tighten this as you solder in and it will hold the core in place. The secondary winding is a

470 ohm resistor R24 which limits the current in the D7. Center the body of the resistor through the core and form the leads as necessary to reach the pads. Make sure they do not contact the ferrite core.

· Install the Molex headers CON1 - 5. D5 will be mounted in a terminal housing (to permit disconnecting AGC). Install CON5 in it's place on the board.

Install the headers for the metering jumpers J3 & 4.

Turn now to the capacitors and refer to the parts list which lists them in groups by size and type. I recommend that you install them one at a time, trimming the leads as you go and striking them off on the parts list. Mount axial capacitors so that the markings remains visible after installation.

· Commence with the 470mF and three 100mF electrolytic capacitors. Make sure that they are correctly polarized and flush with the board.

· Install the two 10mF and five 1mF tantalum capacitors. Again, be absolutely sure that they are correctly polarized.

· Install the 1mF non-polarized ceramic capacitor C10. Re-form the pins to fit the hole spacing if necessary and try not to damage any molded stand-offs.

· Install the fourteen 100nF (0.1mF) ceramic capacitors.

· Install the four 10nF (0.01mF) capacitors.

· You will have noticed that C32 appears twice in the parts list. 5600pF, despite being a standard value, was unavailable. 4700pF in parallel with 1000pF has been substituted. Stack the caps above one another and feed two leads through each hole. They fit easily providing you don't twist them together.

· Install C33A 1200pF polystyrene cap. This is in parallel with C33 but this time separately mounted.

· Install the three 2200pF ceramic caps.

· Install the four remaining 1000pF caps

· Now sort out the seven 680pF caps. Install the two COG caps C40 & 41 in the VFO before installing the remainder. Why two types? COG caps were not available with the 100V rating for the lowpass filter.

· Sort out and install the remaining fifteen ceramic caps.

· Finally, install the trimmer cap C56

· Verify that all caps are accounted for both on the board and out of the bag.

#### **Turn now to the resistors.**

· Install the 21 fixed resistors. For those mounted vertically, form one lead into a 0.1"D semicircle close to the body using the tapered end of a pencil.

· Install the multi-turn trimpots R19 & 20 and orient the adjusting screws as in the parts layout and photograph.

· Insert the shaft in R22 and install. Make sure the pot is square and the shaft horizontal before soldering in place.

· Install the 10-turn precision pot R24 in the center of the panel of the

temporary chassis.

- Install the voltage regulators U7 & 8. U7 is the 8V regulator and U8 is the 9V regulator.
- Install the reverse polarity protection diode D6.
- Install the SSB filter F1 flush with the board. Avoid overheating and do not trim the pins.
- Install the relay K1 flush with the board.
- Install the ceramic resonator X1.

**Before proceeding you can carry out some DC voltage checks.**

- Install the PC board on the temporary chassis. Leave the switch in the off position (down). Do not install any ICs or shorting jumpers.
- Obtain the parts to make up a power lead. Include an inline 5A fuse. The reverse polarity protection is a shunt diode so do not omit the fuse.
- Connect to a 12V DC power supply. If the fuse blows, then either the polarity of the supply is reversed or the protection diode was installed backwards. Rectify this before going any further.
- Place the switch in the on position and check out some voltages with a multimeter. You should be reading 8V at pin 8 of U2 and 12V at pin 6 of U5. No voltage should appear at J4 and pin 7 of U4.
- Ground pin 1 of CON1 to close the relay. You should read 8V at pin 8 of U2, 9V at J4 and 12V at pin 7 of U4. No voltage should appear at pin 6 of U5.

**This completes the test. Refer now to the list of semiconductors.**

- Install Q2, 3 and 4 (MPF102).
- Install D1, 2, & 3 (1N914) observing the polarity. The cathode end is marked with a black band. D1 is mounted horizontally and the cathode end is identified in the parts layout. D2 & D3 are mounted vertically and their cathodes grounded. Form the cathode leads into a 0.1" semicircle. The grounded traces on the board are easy to locate if you are uncertain.
- Install the varactor diode D4.
- Install LEDs D5 & 7 in 2-pin polarized Molex housings but do not mount them on the headers at this stage. It is essential to observe the polarity of D5 or the AGC won't operate. While the polarity of D7 is unimportant you should polarize it the same way as it is unable to tell them apart later!

**Refer to the list of inductors**

- Identify and install the 1000mH choke L11 (epoxy-coated). If you have any doubt measure its DC resistance with an ohmmeter. It should read around 12 ohms.
- Install the three 1000mH chokes L7, 8 & 9 (molded). Form the leads of L7 & 8 as you would for a vertically mounted resistor. Avoid sharp bends near the body as the internal connections are quite fragile.
- Install the four Toko variable inductors L3, 4, 5, & 6. Install L 6 (VFO) first. The remaining three are identical. Use a small solder fillet on each of the mounting lugs to ground and fasten them to the circuit board. It is unnecessary to solder any of pins other than the 2 outside pins of the 3-pin

row. The remainder do not connect to anything.

- Identify the iron powder toroid cores for L1 & 2 (red). Wind each with 20 turns of #24g enameled wire leaving half inch leads. Scrape clean and tin the leads close to the core before installing.

- Identify the ferrite core for L10 (black). The manufacturer lists this as a "bead". Wind with 12 turns of #24g enameled wire leaving one inch leads. Leave the leads long enough for the core to mount in line with the pads clear of adjacent components.

#### **Refer now to the list of transformers.**

- Start with the power amplifier output transformer T2 which is wound on the ferrite binocular core. The primary winding (connected to U1) comprises 2 turns of #24g enameled wire. Pass the wire through each holes twice which leaves both leads projecting from the same end of the core. The secondary winding comprises 5 turns of #26g wire and starts from and finishes at the opposite end of the core. Trim the leads to half inch, tin and install.

- T3, the antenna sensor was installed at the beginning.

- Turn now to the driver output transformer T1 which comprises 5 trifilar turns wound on the remaining ferrite bead. For those of you who have a problem with trifilar windings the following may help. Take three 10 inch lengths of #26g enameled wire and knot them together at each end. Clamp one end in the chuck of a small hand drill and the other in a vise. Keep the wires taut and twist to about 10 turns per inch. Cut off the damaged ends and wind 5 evenly spaced turns on the core. Unravel (rather than untwist) the ends back to the core, straighten and trim each of the 6 leads back to one inch. Clean and tin back the first half inch only or they may short together or against the core. Identify each of the three windings with an ohmmeter. Referring to them as "AA", "BB" & "CC" install T1 on the circuit board as below. Pull each lead through leaving a small portion of the tinned section visible above the top pad before soldering.

### **Power amplifier**

### **Driver**

## **TESTING AND ALIGNMENT**

Most of the testing can now be carried out before the power amplifier is installed. The IRF510 pins are brittle and easily bent when the circuit board is removed. It is better to delay installation until you are satisfied that everything else is functioning correctly.

The antenna and power jack are mounted on the circuit board and Molex connectors are used for all other attachments. The terminals are made to be crimped onto wire. Few amateurs have access to a proper

crimping tool and pliers make a poor job. Form the terminals into a cylinder around the shank of a small drill and solder the leads. To remove a terminal, hold the housing in a vise and extract it with a pointed Xacto blade. It takes a little practice and terminals can be re-cycled several times. Use thin stranded hook-up wire or ribbon cable.

Test equipment does not have to be elaborate. If you do not have an oscilloscope you can make a simple RF probe to use with a multimeter; if you do not have a frequency counter you can get by using a calibrated receiver; if you do not have an audio signal generator you can whistle and groan into the microphone (don't overdo this or your family become concerned about you); if you do not have a spectrum analyzer you can have the amateur next door check your signal quality.

Mount the circuit board on the temporary chassis. It is assumed that you have already made up a fused power lead and carried out the DC voltage checks described on p. 5. Do not install jumpers at J3 & 4.

Connect the "wiper" terminal of the tuning pot R24 to pin 6 of CON2. Connect the "bottom" end of R24 to ground (or chassis) via a 4k7 resistor (not provided). Connect the "top" end R24 to pin 3 of CON2. The connections are usually shown on the pot but easy to determine with an ohmmeter. Verify that the DC voltage on the wiper terminal varies from c. +3V to +8V as R24 is tuned. Leave this set to c. 5V

With an RF probe verify that both oscillators are functioning. Set the LF oscillator to 452.6KHz with the trimmer cap. Tune for the 9th harmonic at 4.074MHz on a closely coupled receiver. Most amateur band receivers tune 100KHz beyond the band edge.

Adjust L6 until the VFO frequency (measured at pin 4 of CON2) is approximately 4.2MHz. To avoid having the slug protrude screw it deep into the can and tune upwards (anti-clockwise) to lower the frequency.

Now install the mixers U2 & 3, and the switch U6 in their sockets. With an RF probe verify that pin 6 on each shows a reading of at least 140mV RMS. These readings are unlikely to be identical. Close the relay by grounding pin 1 of CON1 and the readings should then "switch" indicating that U6 is functioning. A counter will, of course, display the frequency change.

Install the audio amplifier U5 and connect an 8 ohm speaker between pins 1 & 2 of CON2. Touching pin 1 or pin 2 of U5 with your finger should produce a loud hum in the speaker.

Connect an 80M antenna at J1 (the receiver is quite sensitive but will not function using a non-resonant piece of wire). Advance the RF gain pot R22 fully clockwise, tune across the band to find a SSB station and tune L5. Install D5 to establish that the AGC circuit is functioning. **Do not commence testing and aligning the transmitter until you are first satisfied that the receiver is functioning properly.**

Connect an electret microphone element (2-lead type) to pins 2 & 3 of CON1. For testing this may be mounted directly into the terminal housing or through a piece of screened cable. Pin 3 is the ground. At the same



time install a wire to pin 1 for closing the relay. You can add push-button switch or just ground the wire to the chassis for testing.

- Install the pre-amplifier U4. Place a probe on pin 4 of the 2nd mixer U3 to act as a radiator, PTT (close the relay) and speak into the microphone. Monitor the signal on a receiver using headphones. Any problem at this stage is most likely to be in the speech amplifier or microphone since the mixers and oscillators function in the receive mode.

- Set R20 (RF drive) to minimum. This will be fully clockwise if R20 is oriented as shown in the parts layout. Bear in mind that multi-turn trimpots do not have end stops. Install a milliammeter at J4. (use the 2-pin Molex housing supplied for attaching a frequency display and make up a cable). Close the relay and verify that the standing current in the driver U1 is c. 25mA. Open R20 three or four turns, speak into the microphone while monitoring the signal on a receiver using headphones. No radiator should be required.

- Replace the meter with a shorting jumper at J4. PTT and measure the voltage at the gate pad of (yet to be installed) Q1. This is the right-hand pad nearest the driver. Adjust R19 to set this to c. 3.0V. Verify that this drops to zero when the PTT is released. Remove the jumper from J4 and install it on J3. Verify that the drain (center) pad for Q1 reads +12V.

- **Refer to the Diag. D and install Q1. From now on you must make sure that the circuit board is fully grounded to the chassis at all five mounting points.**

- Install a 50 ohm dummy load at J1 and LED D7 at CON4.

- Remove the jumper from J4 (driver current) and install a milliammeter at J3 (PA current). PTT and adjust R19 to set the idling current to 45mA.

- Re-install the jumper at J4, PTT, and modulate with a level tone. The current at J3 will increase and D7 will light. Now tune both sections of the bandpass filter L3 & L4 for maximum current. Do not "stagger tune" the coils. Adjust R20 so that the current at J3 does not exceed 900mA on peaks with normal speech. Verify that the current rapidly drops to the idling level with no modulation.

- Re-check the driver current at J3. Similarly, this should rise to 60 - 70mA with modulation and drop to 25mA.

- You are now ready to go! Connect the antenna and have another amateur check your signal.

**Frequency display:** Several designs were published for LED digital frequency displays for the EP-2. These generated a lot of noise and consumed a lot of current. Today there are several DFD kits available with LCD displays, programmable offsets and none of these disadvantages. K1MG's (Blue Sky Engineering Co.) Digital Clock/ Counter is perhaps least expensive, simplest to build and install.

**Enclosure:** There is nothing to prevent you operating from the test chas-

sis but sooner or later you will want to install it in a professional-looking package. The Ten-Tec TG-26 enclosure should accommodate the EP-3 circuit board and a K1MG DFD nicely. I believe this was used by W6MMA to house the prototype he assembled. The low-profile circuit board is also ideal for installation in a "slim-line" enclosure with the display on top and thumb-wheel tuning.

**Bandspread:** The 4k7 ohm resistor from the 10-turn tuning to ground serves to prevent the voltage at tuning diode dropping to zero. Below one volt it becomes very unstable. So long as this limitation is observed it's value may be changed to set the band spread.

**Frequency stability:** The VFO frequency drops c. 400Hz during the first five minutes after switching on from cold. So long as the temperature within the enclosure remains constant it is quite stable. If you are transmitting for long periods on a net frequency, occasional adjustments are necessary. To compensate for this you can play with the values of C33 and C33A (which have differing thermal characteristics) and install a diode in series with the tuning pot, or make your next project a "huff and puff"!

**Microphone:** The simplest and most foolproof is an electret mic in which the PTT switch directly grounds the relay coil. If the switch is in the mic lead itself (as is the case with most spkr/mics) you will have to install a transistor to switch the relay. If you use a dynamic mic remove the bias resistor R13.

### EPIPHYTE 3 PARTS LIST

#### CAPACITORS

No.	Cap	Type	Source	Stock No.
1	470uF	elect/16V	MOUSER	140-XRL16V470
3	100uF	elect/50V	MOUSER	140-XRL50V100
2	10uF	tant/25V	MOUSER	74-199D25V10
6	1uF	tant/35V	MOUSER	74-199D35V1.0
1	1uF	cer/50V	DIGI-KEY	P4968-ND
14	100nF	cer/50V	DIGI-KEY	1210PHCT-ND
5	10nF	cer/50V	DIGI-KEY	1103PHCT-ND
1	4700pF	cer/50V	DIGI-KEY	1102PHCT-ND
1	1200pF	polystyrene	MOUSER	23PS212
3	2200pF	cer/50V	DIGI-KEY	119PHCT-ND
5	1000pF	cer/100V	DIGI-KEY	116PHCT-ND
5	680pF	cer/100V	DIGI-KEY	1114PHCT-ND
2	680pF	cer/50V	DIGI-KEY	1009PHCT-ND
6	470pF	cer/50V	DIGI-KEY	1007PHCT-ND
2	270pF	cer/100V	DIGI-KEY	1111PHCT-ND
1	100pF	cer/50V	DIGI-KEY	1001PHCT-ND

1	47pF	cer/100V	DIGI-KEY	1017PHCT-ND
4	33pF	cer/100V	DIGI-KEY	1016PHCT-ND
2	15pF	cer/100V	DIGI-KEY	1012PHCT-ND
1	5 - 65pF	trim cap	DIGI-KEY	SG3009-ND

**RESISTORS** (All Resistors 0.25W & vertically mounted unless otherwise specified)

2	100k			
1	47K			
1	15k			
4	10K			
3	4k7			
2	2k2			
1	1k5			
1	1k			
1	470			
1	330			
1	100			
2	47			
1	10			
1	10k	3/8" multi-turn square Cermet trimpot	0.1" in-line pin sp.	
1	100	Multi-turn carbon trimpot	0.1" in-line pin sp.	
1	2k5	PHIER Trimpot extension shaft		
1	10k	10-turn precision tuning pot		

**INDUCTORS**

L1,L2	1.68uH	Iron powder core	20/T #24g enam	T-37-2
L3,4,5	4.7uH	TOKO tunable coil	154AN-T1005	TK1203-ND
L6	3.3uH	TOKO tunable coil	BTKANS9445	DIGI-KEYTK1414-ND
L7,8,9	1000uH	Molded choke	MOUSER	43HH103
L10	40uH	Ferrite Bead	12-turns #24g enam	FB-43-2401
L11	1000mH	Epoxy Coated Choke	Low Res (12 ohms)	
		MOUSER	43LS103	

**TRANSFORMERS**

T1	RF Trans	Ferrite Bead	5 trifilar t. #26g enam	FB-43-2401
T3	Prim. 1 t.	#24g enam	Sec. see text	FB-43-2401
T2	RF Transf	Binocular Prim. 2 t.	#24g enam	Sec. 5 t. #26g enam
				BN-75-202

**CONNECTORS**

J1	PCB Mount	BNC
J2	PCB Mount	DC Power Jack
J3,4	2 Pin Header &	Jumper

**IC's, DIODES & TRANSISTORS**

Q1 IRF510  
Q2 MPF102  
Q3 MPF102  
Q4 MPF102  
U1 CA3020 or CA3020A  
U2 NE602, NE612, SA602, SA612  
U3 NE602, NE612, SA602, SA612  
U4 LM741  
U5 LM386-4  
U6 MC4066  
U7 78L08  
U8 78L09  
D1 1N914  
D2 1N914  
D3 1N914  
D4 MVAM108, 1SV149  
D5 Red or Green LED, High Eff. 2.1Vf  
D6 1N4005  
D7 Red or Green LED

#### **MISC.**

F1 MuRata M455J1 Ceramic SSB Filter  
X1 455 kHz Ceramic Resonator  
K1 Miniature 12V DPDT Relay  
SW1 PCB Mount SPDT Switch  
4 8 pin IC Sockets (Optional)  
1 14 pin IC Socket (Optional)  
1 TO220 Thermal Mounting Kit  
1 Nylon Bushing  
1 1/4 x 4-40 Machine Screw and Nut  
4 PCB Standoffs, 1/4" x 4-40

## SMK-1 ROCK-BOUND NO MORE

by Wayne McFee NB6M

I have had so much fun with the little SMK-1 that I couldn't help thinking how much more fun I might have with it if only it had a VFO. I thought "why not?" So, I got started thinking about what all I would have to change or add in order to couple a VFO to the receiver and transmitter circuits in the SMK-1.

### INITIAL PLANNING

First of all, I would have to remove both VXO crystals and their associated circuitry. Then, I would have to modify the transmitter's oscillator circuit so that it would act as an amplifier instead of as an oscillator. Not only would I need to build a stable VFO, with sufficient tuning range to cover most of the CW portion of the band, I would need to provide for transmitter frequency offset, and, since the receiver would no longer have its own LO, a means for providing sidetone would have to be added to the rig.

After a little thought, and some experimental work, the result is a very nice VFO, with RIT and transmitter frequency offset a la Roy Lewallen, W7EL, a tuning range of from just below 7.000 MHz to 7.115 MHz, NO expensive tuning capacitors or even tuning diodes to buy, and only one tuning coil and two toroids to wind. The rest of the VFO, including the RIT circuit, is all built with cheap, easy to come by (Radio Shack) parts.

In perusing the Internet for any and all QRP related info, I had seen a circuit on WA6OTP's website for a Permeability Tuned Oscillator which used a small diameter, air wound coil, with a 6-32 brass screw threaded into the center, as a tuning element. That got me really excited. That tuning element was just what I was looking for. The tuning coil was small, would cost almost nothing to make, and would provide not only the inherent stability of an air-wound coil, but, with the brass tuning screw, would provide plenty of tuning range. Also, with the use of brass as the varying element, the VFO frequency would increase, as the tuning knob was turned clockwise, just like radios "normally" tune. Nice.

As it turns out, at the low end of the tuning range, one full turn of the tuning knob moves the VFO output about 8 KHz. At the upper end of the tuning range, one full turn of the tuning knob moves the VFO output about 13 KHz. Not quite linear, but not bad at all.

Considering the fact that I wanted to eventually be able to build the VFO right inside the small confines of my SMK-1 case, which puts space at a premium and almost precludes adding a lot of shielding around the VFO oscillator, I wanted to put the VFO on 3.5 MHz and employ a frequency doubler circuit in order to arrive at 7 MHz. This would minimize any inter-action between the transmitter signal and the VFO, preventing

any pulling or chirping.

Since removing the VXO circuitry for both the receiver and transmitter would mean that I now had a couple of spare 10K pots, I thought why not remove the Receiver's VXO pot completely and use that position as the eventual location for the tuning coil, and why not use the Transmitter's old VXO pot as an RIT control, since by providing an RIT circuit, a la W7EL, I would not only have transmitter offset but would enjoy RIT as well.

The RIT circuit, with the values used, provides about 1.5 KHz of tuning range. Just about right for a 600 to 800 cycle tone with the RIT control centered in its range and with the transmitter tuned for zero beat on an incoming signal. The "Spot" switch makes tuning signals really easy. Simply hold the Spot switch in, tune the VFO for zero beat on the incoming signal, release the Spot switch, and adjust the RIT control for the desired tone pitch.

As for providing sidetone, a couple of routes came to mind. A sidetone oscillator circuit could be built in, but since I really like and enjoy the little Tick Keyers, I thought why not put in a Tick chip and keying transistor, and run the audio from the Tick to the audio chain as sidetone. This route has been used successfully in several rigs, including the Tixie, and works very well. The choice is yours.

## **BUILDING THE VFO**

Now that I had a plan, the work could begin. As a very fitting start, at a NorCal meeting at California Burger, in Pleasanton, I kept the drinking straw from my soft drink to use as my coil form. It was a nice, substantial one of 5/16" diameter. WA6OTP had used old potentiometer housings as a building platform for his coils, but I elected to do it an even easier way. Using an electric grinder, I rounded the corners off a brass 6-32 nut, rounding it to a size that the drinking straw would just fit over.

Then, after drilling a clearance hole in the front panel of the VFO, which is double sided PC board, I threaded the rounded nut onto a brass 6-32 screw, set the screw in the hole, with the rounded nut on the inside surface of the front panel, and soldered the rounded brass nut to the inside surface.

Then, threading a new 6-32 brass nut onto the screw on the outside of the front panel, I tightened it down just enough to provide added thread support, but not tight enough to prevent easy turning of the tuning screw. Once that was done, I soldered the outside brass nut to the surface of the front panel.

While allowing the assembly to cool, I used a sewing needle to poke small holes close to one end of the drinking straw in order to anchor the end of the # 30 magnet wire used in the tuning coil, and wound 95 turns, close-wound, onto the 5/16" diameter drinking straw. Although the coil needs about three less turns than that in its final version, the extra turns provide plenty of room for error. It is quite easy, after the entire VFO



circuit is finished, to remove coils one at a time to make the needed frequency adjustment.

The sewing needle was again used to poke small holes in the straw, next to the last turn, to anchor the end of the coil in place. The coil form (drinking straw) is easily trimmed, close to the anchored last turn, with scissors. Once the coil form is trimmed, use 5 minute epoxy to fasten one end of the coil form over the rounded brass nut, up against the inside surface of the VFO front panel. Use the tuning screw itself, a 6-32 brass screw about 1 1/4" long, as a guide to ensure that you have the coil on straight.

The head is cut off the screw to facilitate installing a small tuning knob, and mine ended up being just over an inch long, including the portion that is inside the knob. Leave yours 1 1/4" long to begin with, and cut it as you like to give the upper frequency limit you wish.

In my experimental version, all the VFO, RIT and Keyer stages are built "Ugly" style, in the manner of Wes and Roger Hayward, W7ZOI and KA7EXM. The final version, which will be installed in my SMK-1 with the 5 Watt Mod, will probably be done in "Ugly" style as well, but with a great deal more thought given to parts placement and circuit miniaturization.

Since this VFO would do very well as a stand-alone module which could be used with your choice of QRP rig, I would suggest that you give some thought to building your version in a case of its own, particularly if you have put your SMK-1 into a minimally sized case. The VFO box would need to be supplied with 12 Volts (or could be battery supplied). A wire would be needed from the VFO to the rig's keying line to provide for RIT (and transmitter frequency offset) disabling during transmissions, and a small coaxial cable would run the VFO output to the rig. As long as the rig had it's own sidetone, no more cabling would be needed.

The two 22 pf caps shown on the VFO output would be installed inside the rig itself, one at the input of the transmitter amplifier and one at the receiver mixer. In that fashion, only a single VFO RF Output cable would be needed to connect to the rig.

In order to make the building process easier, I have provided additional circuit diagrams that break the main circuit diagram down into four parts, detailing the Oscillator, RIT circuit, First Buffer Amplifier and Frequency Doubler, and Tuned Buffer Amplifier. I have separated the parts list into four sections in the same manner, so that you can gather the parts for each stage individually. The building style is up to you. "Ugly Style" works very well. "Manhattan Style" would also be a good choice. You could even design a printed circuit board, if you wish. Mine is built "Ugly Style" and works very well.

I suggest that you build the oscillator circuit first. DO NOT coat the entire coil with epoxy or other fixative yet, as a few turns will have to be taken off in order to fine-tune the frequency range. Be mindful of the fact that the 4.7 K biasing resistor, the top lead of the primary of T-1 and the 47



Ohm resistor for the voltage supply to the Tuned Buffer Amp will all have to attach to the junction of the 100 Ohm resistor, 220 Ohm resistor, .01 Cap and 100 UF Cap, so plan accordingly in your layout. Also, NOTE that all the small value capacitors (values in pf) are NP0, Poly, or Silver Mica. Good chance to use some of those NorCal capacitors, hi.

Once the oscillator is built, apply 12 Volts and check for oscillation by listening for the output in a general coverage receiver, or by measuring the RF level at the Drain of the MPF-102 (about 3-4 volts RMS), or by looking at the waveform with an oscilloscope.

You will probably have to listen well below the 3.5 MHz Fundamental Frequency initially. At this point we are just checking for oscillation, so don't make any frequency adjustments to the coil until after the amplifier and frequency doubler stages are all completed, as the loading effect of these stages will affect the frequency of the oscillator.

Once you have confirmed oscillation, build the next portion, the RIT circuitry. The RIT disabling transistor, Q-2, and its associated parts can be mounted on the RIT pot itself, if desired, which helps make for a neater installation. Also, you may want to hook up the RIT pot only temporarily at first, to ensure that you get the correct rotation. You want the RIT pot to tune the same direction as the main tuning knob, up in frequency with clockwise movement.

The "Spot" Switch, a "Normally Open" push-button type switch, is mounted in a convenient spot on the front panel of the VFO. Test both the frequency offset function, by pushing the Spot Switch, and the RIT function, by turning the RIT control and listening to the output in your general coverage receiver. Remember that when you are listening to the 3.5 MHz fundamental frequency, the tuning range will only be about 750 Hz.

Once the RIT section is completed and tested, build the First Buffer Amplifier and Frequency Doubler. T-1 is a tri-filar winding of # 26 or # 28 magnet wire on a T37-61 core. Be sure to observe correct polarity when making its connections to Q-3 and the frequency doubler diodes.

Also, it will be important to measure the forward resistance of the diodes used, selecting two with the closest resistance measurements so as to balance the doubler, which will help ensure that the lowest amount of fundamental frequency energy possible will be felt at the VFO output.

If you have an oscilloscope, you can look at the waveform on both the input of the First Buffer Amplifier and the output of the Frequency Doubler to check their function. Alternatively, measure the RF output on the Collector of the First Buffer Amplifier, and then again on the output of the Frequency Doubler.

On mine, the approximate RF voltage readings are as follows:

Drain of Oscillator	4 Volts RMS
Base of First Buffer Amp	.8 Volts RMS
Collector of First Buffer Amp	2.2 Volts RMS
Output of Frequency Doubler	.48 Volts RMS

When the First Buffer Amplifier and Frequency Doubler section is finished and tested, build the Tuned Buffer Amplifier section. T-2 has a primary of 19 turns # 24 on a T50-2. The secondary is a 3-turn link spread over the center area of the primary.

A T37-2 could probably be used, to reduce the size, but a few more turns will be needed. A 21-turn primary would be a good start, but the 240 pf capacitor might have to be changed to 220 pf to get it to resonate. Remember that the 240 pf cap is either a NP0, Poly, or Silver Mica.

When the Tuned Buffer Amplifier section is built, now is the time to make frequency adjustments to the tuning coil. Hook an RF probe onto the top of the 3-turn link on T-2 and adjust the trimmer to see if the circuit will resonate at the second harmonic of the oscillator frequency, adjusting for highest output.

Alternatively, you can listen for the second harmonic on your general coverage receiver and adjust the trimmer for loudest signal. Although mine resonated both at the second harmonic of 6.880 MHz initially, and at the final second harmonic of 7.050, don't be too upset at this point if your trimmer won't bring the tuned amp to resonance at your initial, lower second harmonic. Just adjust for the most output you can get at this point.

To make the frequency range adjustment on the tuning coil, start by removing the tuning screw completely. This will ensure that you are at the lowest frequency possible to tune. Remove supply voltage from the circuit. Then, remove one turn from the coil, trim, scrape and tin the wire, and re-solder it into the circuit.

Use your general coverage receiver, or a frequency counter if you have one, to check the new low-frequency end of the tuning range. NOTE how much the frequency changed when one turn was removed from the coil. If you want full coverage of the low end of the band, as I did, once you get the new low-end frequency within 20 KHz of 7.000 MHz, that is probably close enough.

However, it is your responsibility to ensure that you don't transmit outside the band. The safest way would be to set the low frequency limit up just above 7.000 MHz, removing one turn at a time until you have the frequency set. Once the coil is adjusted for a low frequency limit inside the band, small amounts of capacitance (2 pf, for example) can be added from the Drain of the oscillator to ground to make fine adjustments downward, if needed.

My first version tunes from about 6.990 to 7.115 MHz, with a screw just over an inch long. I could increase the upper limit by using a slightly longer screw, perhaps 1 1/4", which probably would get me up past 7.150 MHz.

Remember, it is much more difficult to add turns, once they are cut off, so if the lower frequency is close, and you have tuning range to suit you, leave well enough alone. However, if you do make a mistake and cut one or two turns too many, don't despair. Simply add a small amount of ca-

pacitance, say 2 pf, 4.7 pf, 10 pf, or 12 pf, NP0, from the Drain of the oscillator to ground, and that will bring the frequency back down.

Now that the oscillator is on the right frequency range, coat the winding of the tuning coil to fix the turns solidly in place. This is very necessary, in order to provide the best stability from the oscillator and VFO output. I used 5-minute epoxy, and coated the entire surface of the winding.

Also, now that the VFO output is in the right frequency range, the trimmer on the output of the Tuned Buffer Amplifier will have to be re-adjusted. Tune the VFO to the center of your tuning range, and either use an RF probe or an oscilloscope to monitor the adjustment of the trimmer. Trim for best output and/or the cleanest waveform. The RF voltage reading at the top of the 3-turn secondary of T-2 is approximately .78 Volts RMS.

During my initial on-the-air trials of the VFO and SMK-1 combination, just to double check, I had a nearby ham listen for the fundamental frequency while I transmitted, and received a clean, nothing heard, report. Should you end up with too much fundamental frequency in your VFO output, it would indicate that the Frequency Doubler diodes were not matched initially, or could have been overheated when being installed, which resulted in their forward resistance characteristics changing.

## **MODIFICATIONS AND CABLING TO SMK-1**

Dual soldering irons are a must for this project. With those, the most interesting part of the exercise will be removing the removed part from whichever iron it sticks to. I recommend a damp pad of cloth to wipe the part off on.

As indicated, I removed both VXO crystals and their associated circuitry from the SMK board. This included X-1, VR-2, C-15, R-2, L-3, C-4, C-5, R-3, D-3 and D-4 in the receiver, and X-2, R-7, D-6, D-7, and C-16 in the transmitter. All the parts are taped down to a sheet of paper, and their values written next to them, one at a time as they are removed. Then the parts, with their identifying info, are appropriately filed away for later use.

If you have enough room to build the VFO inside your SMK case, cut the PC Board 12 Volt trace that goes to the VR-3 connection closest to the right hand edge of the board, cut the opposite, left hand VR-3 contact itself that goes to ground and unsolder and remove the cut off portion of the VR-3 contact.

The 12 volt trace going to the + side of VR-3 is cut just about even with the ground end of D-3. That leaves 12 volts going to the pad for C-15, which will allow us to pick up 12 volts for the base circuit of the 2N3906 RIT disabling transistor there, and will keep the trace going from the + side of VR-3 to the + side of VR-2's connections going, so that we can put the 680 resistor for the RIT pot there, and run a wire from the 6 Volt side of C-6 to the R-2 pad closest to X-1's location in order to supply the RIT circuit with 6 Volts regulated.

The 4.7 K Ohm resistor in the RIT circuit is run from the cut off contact on the VR-2 side of VR-3 to ground. The 2N3906 is soldered directly to the wiper and 6 Volt contact of VR-3, with the emitter going to the 6-volt contact and the collector going to the wiper. A wire also connects to the wiper to run to the junction of the 47 K Ohm resistor, .01 cap and the cathode of the 15 Volt Zener, which are all located on the oscillator board, close to the Drain of the MPF102. The 100 K Ohm resistor in the base circuit of the 2N3906 runs from the + pad of C-15's location straight up, and the 10 K Ohm resistor connects to the top of the 10 K resistor and goes to the base of the 2N3906. The .01 cap is connected at the junction of the 10 K and 100 K resistors, and goes to the ground pad for D-4.

The 1N914 goes from the junction of the 10 K, 100 K and .01 to the key line side of R-16, with the cathode towards R-16. The spot switch is connected from the junction of the 10 K, 100 K, .01 and 1N914 to ground and is located in a convenient spot on the front panel.

That places all the RIT control and switching circuitry on the SMK board, at or near VR-3's location, leaving fewer components on the VFO board. The main VFO board could then be integrated into the top and left side of the SMK case, leaving the right side for the 1 Watt or 5 Watt Mods, if desired, or could be stacked below the main SMK board, with the VFO board near the SMK board and the components of the VFO board facing away from the SMK board and the tuning screw protruding through the front of the case.

If you are going to build the VFO as an outboard item, VR-3 is removed. An easy way to remove VR-2 and VR-3 is to cut their contacts at the top surface of the SMK-1 PC Board. This still leaves enough contact remaining to solder to and use one of them as an RIT control.

If you are planning on making your VFO an outboard item, the two 22 pf caps shown on the output of the VFO are installed on the SMK-1 board. With all the VXO related parts removed from the board, the two 22 pf caps can go quite nicely in the X-1 and C-16 locations. A wire soldered to the L-3 pad closest to the X-1 location, the R-7 pad closest to Q-2, and running to a jack on the back of the rig, for VFO input, would then complete the VFO-to-Rig RF connection inside the SMK-1.

In order to change the transmitter oscillator on the SMK-1 board into an amplifier, you will need to remove R-8 and C-18 from the circuit. Then, move R-9, the 4.7 K Ohm resistor, to R-8's old position (changing R-8's value from 47 K to 4.7 K) and install a leaded 1500 Ohm resistor in R-9's place.

How you provide for a keying line for the Frequency Offset/RIT circuit will depend on whether you choose to build a keyer into your rig or not. If you do, then you will have to provide a jack and cable for that line to the VFO. If you use an outboard keyer and an internal sidetone oscillator, one way to provide the keying line to the VFO would be to use a one plug to two jack adaptor in the key jack on the back of the rig, and plug both the keyer

and the key line from the VFO into that. Those decisions are for you to make.

Also, if you elect to install a Tick Keyer in order to provide sidetone (not to mention the benefits of a keyer, apply the audio, using the circuit components described in the Tick circuit diagram provided with the chip, to the input of U-2 at pin 3, and make resistor value adjustments as necessary to adjust the sidetone level to your liking.

## FINAL THOUGHTS

Yes, I know this project is a bit more complicated than adding the 5 Watt Mod to the SMK-1. However, it is a very worthwhile project that can be used with a variety of small, formerly rock-bound, QRP rigs, and, taken in stages, is not difficult at all to build. Just imagine being able to tune the whole CW portion of the band, with RIT thrown in for good measure. And, with a 1.5" long tuning screw, the VFO will tune the entire 40 Meter band, allowing you to listen to your favorite 40 Meter SSB activity as well as doing your regular CW operation on the lower part of the band.

I have worked Japan and other far away places on the low end of 40 Meters with one watt out of other QRP rigs, at sunrise in the morning, and I am eager to try it with my VFO-controlled SMK-1 with its stock 300 MW output.

Should you wish to use the VFO for another band, the oscillator, with the 120 pf cap removed, and with the number of coil turns adjusted downward appropriately, is quite stable certainly up past a 7 MHz fundamental frequency, which would give you 30 and 20 meter capability. I suspect that, with care, it might even be stable enough for a 10.5 or 14 MHz fundamental, which would provide for operation through 10 Meters. It would certainly be worth experimenting with.

Enjoy,

Wayne NB6M

## PARTS LIST

### OSCILLATOR

Q-1           MPF102, 2N3829, 2N4416, etc  
D-1           6.2 V, 1 W Zener

### Resistors

1   100 Ohm  
1   220 Ohm  
1   100 K Ohm

### Capacitors

1   270 pf NP0  
2   120 pf NP0  
1   150 pf NP0  
2   .01 Disc Ceramic  
1   100 UF 16 Volt Electrolytic

## Inductors

- 1 22 uh RF Choke
- 1 Home-Made Tuning Coil

SMK VFO Oscillator

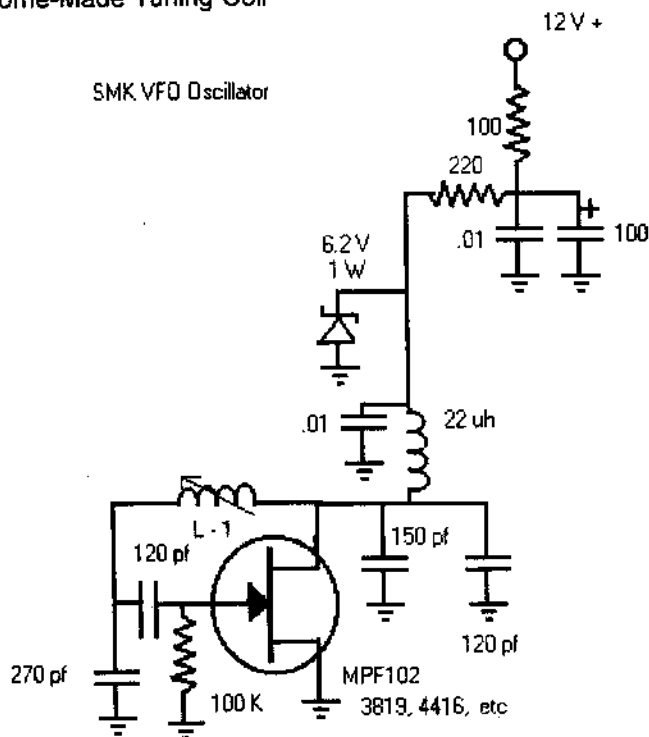

## RIT CIRCUIT

- 1 Q-2 2N3906
- 1 D-2 15 V, 1 W Zener
- 1 D-3 1N914, 1N4148, etc
- 1 SW-1 NO miniature push-button
- 1 RIT Control 10K Linear Pot

### Resistors

- 1 100 K Ohm
- 1 10 K Ohm
- 1 560 Ohm
- 1 4.7 K Ohm
- 1 1 M Ohm
- 1 47 K Ohm

### Capacitors

- 1 .1 Disc Ceramic
- 1 .01 Disc Ceramic
- 1 4.7 pf NPO

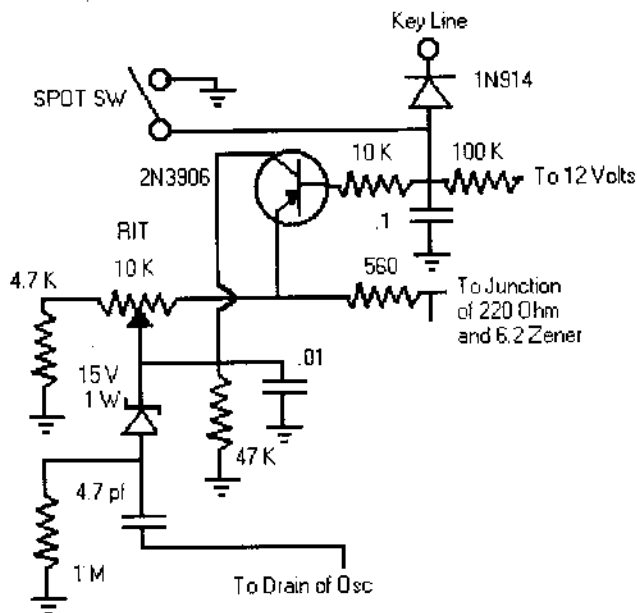

SMK RIT

### FIRST BUFFER AMPLIFIER AND FREQUENCY DOUBLER

- 1 Q-3      2N2222, 2N3904, 2N4401, etc
- 2 D-4, D-5    1N914, 1N4148, etc
- 1 T-1      10 Tri-Filar Turns # 26 or # 28 on T37-61

#### Resistors

- 1 4.7 K Ohm
- 1 470 Ohm
- 1 100 Ohm

#### Capacitors

- 1 22 pf NP0
- 1 .01 Disc Ceramic

#### Inductors

- 1 22 uh RF Choke

### TUNED BUFFER AMPLIFIER

- 1 Q-4      2N2222, 2N3904, 2N4401, etc
- 1 T-2      Primary, 19 Turns # 24 on T50-2 Secondary, 3 Turn Link, spread on Center of Primary

#### Resistors

- 1 47 Ohm
- 1 6.8 K Ohm
- 1 470 Ohm
- 2 100 Ohm

## Capacitors

- 2 .01 Disc Ceramic
- 1 240 pf NP0
- 1 60 pf Trimmer Capacitor
- 2 22 pf NP0

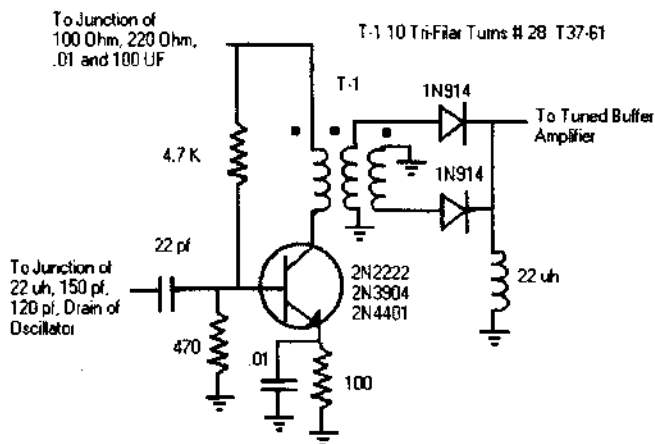

SMK VFO First Buffer Amplifier and Frequency Doubler

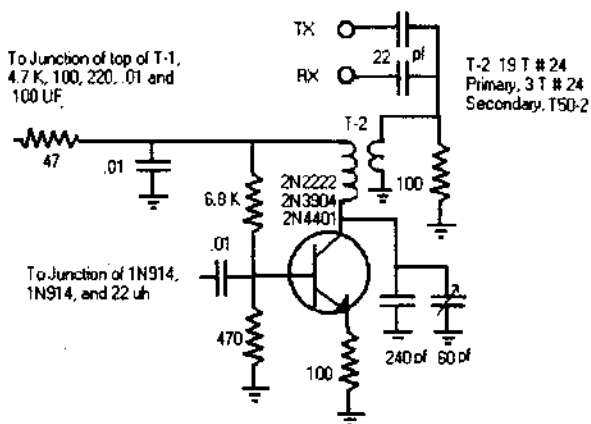

SMK VFO Tuned Buffer Amplifier



# QRPP Subscriptions

QRPP is printed 4 times per year with Spring, Summer, Fall and Winter issues. The cost of subscriptions is as follows: US and Canadian addresses: \$15 per year, issues sent first class mail. All DX subscriptions are \$20 per year, issues sent via air mail. To subscribe send your check or money order made out to Jim Cates, NOT NorCal to: Jim Cates, 3241 Eastwood Rd., Sacramento, CA 95821. US Funds only. Subscriptions will start with the first available issue and will not be taken for more than 2 years. Membership in NorCal is free. The subscription fee is only for the journal, QRPP. Note that all articles in QRPP are copyrighted and may not be reprinted in any form without permission of the author. Permission is granted for non-profit club publications of a non-commercial nature to reprint articles as long as the author and QRPP are given proper credit. The articles have not been tested and no guarantee of success is implied. If you build circuits from QRPP, you should use safe practices and know that you assume all risks.

## Back Issues QRPP

1993 - \$10

1994, 95, 96, 97- \$15 per issue

1998, 99 - \$20 per issue

**Shipping & Handling: US:** \$4 for 1 - 3 issues. \$5 for 4 - 7 issues.

**Canada:** \$4 for 1 issue \$5 for 2 - 3 issues \$7 for 4 - 7 issues.

**DX Europe & South America:** \$5 for 1 issue \$7 for 2 - 3 issues \$10 for 4 - 7 issues **DX Pacific Rim, Australia & New Zealand:** \$5 per issue ordered \$10 for 2 issues \$15 for 3 issues \$20 for 4 issues, etc.

Send Check or Money order in US Funds only to:

**Doug Hendricks**

**862 Frank Ave.**

**Dos Palos, CA 93620**

NOTE: Make Checks Payable to Doug Hendricks NOT NorCal

**QRPp, Journal of the NorCal QRP Club**  
862 Frank Ave.  
Dos Palos, CA 93620

**First Class Mail**

**First Class Mail**  
**U.S. Postage**  
**Paid**  
**Mailed from Zip Code**  
**93620**  
**Permit #72**

Subscription expires with Fall 01 issue.  
|||||

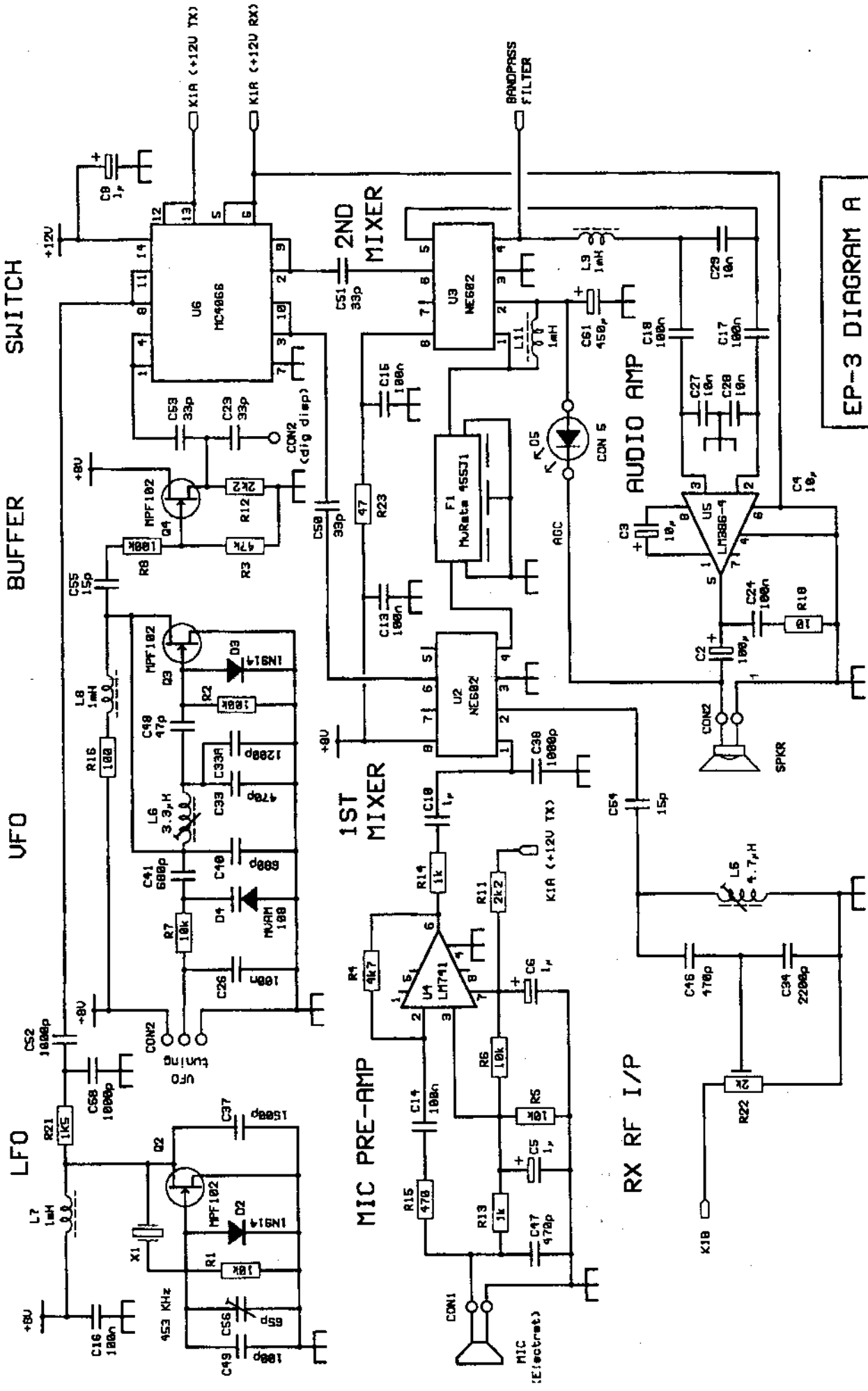

**EP-3 DIAGRAM A**  
 EP-3(A). SCH 28-85-2888

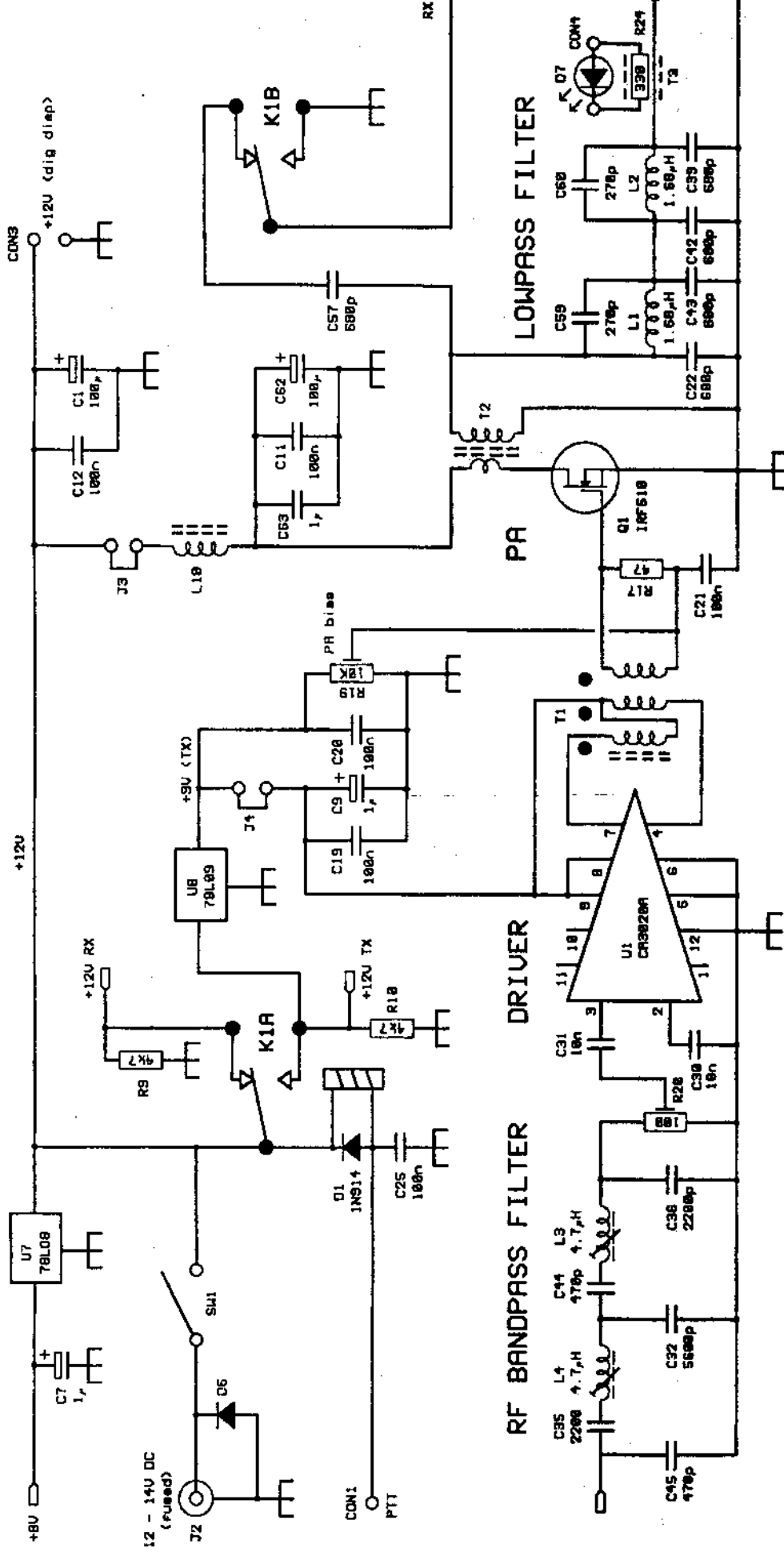

EP-3 DIAGRAM B  
EP-3(B).SCH 28-85-2888